

CODE OF PRACTICE FOR CONCRETE ROAD BRIDGES

(First Revision)



**INDIAN ROADS CONGRESS
2020**

**CODE OF PRACTICE
FOR
CONCRETE ROAD BRIDGES**

(First Revision)

Published by:

INDIAN ROADS CONGRESS

Kama Koti Marg,
Sector-6, R.K. Puram,
New Delhi-110 022

JULY, 2020

Price : ₹ 1500/-
(Plus Packing & Postage)

IRC:112-2020

First Published : November, 2011
Reprinted : December, 2012
Reprinted : June, 2014 (Incorporating all Amendments/ Errata published in Indian Highways upto June, 2014)
Reprinted : November, 2016
First Revision : July, 2020 (Incorporating all Amendments/ Errata published in Indian Highways upto June, 2020)

(All Rights Reserved. No part of this publication shall be reproduced, translated or transmitted in any form or by any means without the permission of the Indian Roads Congress)

Printed by India Offset Press, Delhi - 110 064
1100 Copies

SECTION 1 CONTENTS

S.No.	Description	Page No.
Section 1	Contents	
	Personnel of the Bridges Specifications and Standards Committee	i-ii
Section 2	Introduction	1
Section 3	Definitions and Notations	3
	3.1 Terms and Definitions	3
	3.2 Notations	9
Section 4	General	14
	4.1 Scope	14
	4.2 Underlying Assumptions	14
Sections 5	Basis of Design	15
	5.1 Aims of Design	15
	5.2 Limit State Philosophy of Design	16
	5.3 Limit States	16
	5.4 Actions and their Combinations	18
	5.5 Representative Values of Properties of Materials	19
	5.6 Analytical Methods to Evaluate Behaviour of Structures	20
	5.7 Design Based on Full Scale Testing	20
	5.8 Durability Aspects	20
Section 6	Material Properties and their Design Values	22
	6.1 General	22
	6.2 Untensioned Steel Reinforcement	22
	6.3 Prestressing Steel	25
	6.4 Concrete	28
Section 7	Analysis	40
	7.1 General Provisions	40
	7.2 Analyses for Serviceability Limit States	42
	7.3 Analyses for Ultimate Limit States	43
	7.4 Torsional Effects	43
	7.5 Combined Global and Local Effects	44
	7.6 Structures and Structural Frames	44

7.7	Composite Concrete Construction	46
7.8	Structural Effects of Time-Dependent Properties of Concrete	48
7.9	Prestressed Members and Structures	49
7.10	Design and Detailing for Curved Tendons in Thin Sections	52
7.11	Special Load Transferring Devices	54
Section 8	Ultimate Limit State of Linear Elements for Bending and Axial Forces	55
8.1	Scope	55
8.2	Strain and Stress Distribution at Ultimate Limit State	55
8.3	Biaxial Bending	58
Section 9	Ultimate Limit State of Two and Three Dimensional Elements for Out of Plane and in Plane Loading Effects	61
9.1	Scope	61
9.2	One-Way and Two-Way Slabs and Walls	61
9.3	Sub-elements of Box Structures	61
9.4	General Solution for Two-Way Slabs, Walls and Shell Elements	61
Section 10	Ultimate Limit State of Shear, Punching Shear and Torsion	64
10.1	Scope	64
10.2	Design of Flexural Members for Shear	64
10.3	Design Method	68
10.4	Design for Punching Shear	79
10.5	Torsion	85
Section 11	Ultimate Limit State of Induced Deformation	88
11.1	General	88
11.2	Simplified Criteria for Second Order Effects	89
11.3	Method of Analysis for Obtaining the Second Order Effects	92
11.4	Lateral Instability of Slender Beam	98
Section 12	Serviceability Limit State	100
12.1	General	100
12.2	Stress Limitation	100
12.3	Limit State of Cracking	101
12.4	Limit State of Deflection	108
Section 13	Prestressing Systems	110
13.1	General	110

13.2	Anchorage for Post Tensioning Systems	110
13.3	Mechanical Couplers	111
13.4	Sheathing Ducts and Joints	111
13.5	Anchorage Block Design and Detailing	113
13.6	Protective Grouting	117
13.7	Protection of Post Tensioned Tendons and Anchorages	117
Section 14	Durability	118
14.1	General	118
14.2	Common Mechanisms Leading to the Deterioration of Concrete Structures	118
14.3	Design for Durability	118
14.4	Additional Provisions for Specific Mechanisms of Deterioration	121
Section 15	Detailing: General Requirements	124
15.1	General	124
15.2	Reinforcing Steel	124
15.3	Prestressing Units	136
15.4	Coated Steels	141
Section 16	Detailing Requirements of Structural Members	142
16.1	General	142
16.2	Columns of Solid Section	142
16.3	R.C. Walls and Wall Type Piers	144
16.4	Hollow Piers/Columns	144
16.5	Beams	145
16.6	Solid Slabs	150
16.7	Corbels	154
16.8	Articulations	155
16.9	Deep Beams	155
16.10	Members with Unbonded Tendons	156
16.11	Concentrated Forces	156
16.12	Forces Associated with Change in Direction	158
16.13	Indirect Supports	158
16.14	Anchorage Zones for Post Tensioning Forces	159
Section 17	Ductile Detailing for Seismic Resistance	160
17.1	General	160

17.2	Concrete Piers/Columns	160
17.3	Foundations	166
Section 18	Materials, Quality Control and Workmanship	168
18.1	General	168
18.2	Untensioned Steel	168
18.3	Prestressing Steel	170
18.4	Material Ingredients of Concrete	172
18.5	Mix Proportions of Concrete	175
18.6	Acceptance Criteria	179
18.7	Self-Compacting Concrete	180
18.8	Grouting	182
18.9	Quality Control and Workmanship	186
18.10	Design Consideration for Construction stage	195
Normative Annexures		
A-1	Actions, Design Situations and Combination of Actions	196
A-2	Additional Information and Data about Properties of Concrete and Steel	201
A-3	List of Standards and other Normative References	210
A-4	Structural Design by Working Loads / Allowable Stresses Method (Deleted)	
A-5	Test on Mild Steel and Corrugated HDPE Sheathing Ducts	214
A-6	Design Consideration for Construction Stages	222
A-7	State wise Average Annual Relative Humidity	225
Informative Annexures		
B-1	Concrete Shell Elements	231
B-2	Mechanisms of Deterioration of Concrete Structures	238
B-3	Effect of Live Loads on Deck Slabs	240

PERSONNEL OF THE BRIDGES SPECIFICATIONS AND STANDARDS COMMITTEE

(as on 6th December, 2019)

- | | |
|-----------------------------------------|----------------------------------------------------------------------------------------------------------------------------------|
| 1. Pandey, I.K.
(Convenor) | Director General (Road Development) & Special Secretary to Govt. of India,
Ministry of Road Transport and Highways, New Delhi |
| 2. Balakrishna, Y
(Co-convenor) | Additional Director General, Ministry of Road Transport and Highways,
New Delhi |
| 3. Kumar, Sanjeev
(Member-Secretary) | Chief Engineer (R), S,R&T, Ministry of Road Transport & Highways, Transport
Bhavan, New Delhi |

Members

- | | |
|-------------------------------|---------------------------------------------------------------------------------------|
| 4. Bagish, Dr. B.P. | Chief Engineer (Retd.), Road Construction Department, Bihar |
| 5. Banerjee, A.K. | Member (Technical) (Retd.), National Highway Authority of India |
| 6. Basa, Ashok | Managing Director, CEM Consultant (P) Ltd. |
| 7. Bhide, D.A. | Vice President (Design), MRMPL |
| 8. Bhowmick, Alok | Managing Director, B&S Engineering Consultants Pvt. Ltd., UP |
| 9. Chakrapani, R.V. | Managing Director, Aarvee Associate, Hyderabad |
| 10. Gairola, Col. Pradeep | GM (Project), BRIDCUL, Dehradun |
| 11. Garg, Sanjay | Chief Engineer, Ministry of Road Transport and Highways, New Delhi |
| 12. Ghoshal, A. | Principal Advisor, STUP Consultants (P) Ltd. Kolkata |
| 13. Gupta, Dr. Supratic | Assistant Professor, IIT Delhi |
| 14. Heggade, V.N. | CEO, STUP Consultants Pvt. Ltd., Mumbai |
| 15. HOD Bridge Division, CRRI | (G.K. Sahu), CSIR-CRRI, New Delhi |
| 16. Jaigopal, R.K. | MD, Struct Geotech Research Laboratories (P) Ltd. Bengaluru |
| 17. Jatkar, Mohan | Advisor, Gammon India Ltd. |
| 18. Kataria, Ranjan | Executive Director (Technical), Delhi Metro |
| 19. Koshi, Ninan | DG(RD)&AS (Retd.), Ministry of Surface Transport, New Delhi |
| 20. Maheshwari, Dr. B.K. | Professor, IIT Roorkee |
| 21. Managing Director, RSRDC | (M.G. Maheshwari, MD) RSRDC, Jaipur |
| 22. Managing Director, UPSBC | (Ranjan Mittal, MD) UPSBC, Lucknow |
| 23. Manisekar, Dr. R. | Sr. Scientist, CSIR-SERC, Chennai, Tamil Nadu |
| 24. Mishra, Dr. Sudhir | Professor (CE), IIT Kanpur |
| 25. Nirmal, S.K. | Secretary General, IRC |
| 26. Patankar, V.L. | Addl. Director General (Retd.), Ministry of Road Transport and Highways,
New Delhi |
| 27. Prasad, Mathura | Superintending Engineer, PWD Delhi |
| 28. Puri, S.K. | DG(RD)&SS (Retd.), Ministry of Road Transport and Highways, New Delhi |
| 29. Rao, P. Ravinder | Engineer-in-Chief (R&B) State Roads, CRN, PPP & RDC, Telangana |

- | | |
|---------------------------------------------------------------------|-----------------------------------------------------------------------------------|
| 30. Director General, BRO | (Anil Kumar, Chief Engineer) Border Road Organization |
| 31. Sharan, G. | DG(RD)&SS (Retd.), Ministry of Road Transport and Highways, New Delhi |
| 32. Sharma, R.S. | Managing Director, Sugam Technocrats Pvt. Lt., New Delhi |
| 33. Sinha, B.K. | Chief Engineer, Ministry of Road Transport and Highways, New Delhi |
| 34. Sinha, N.K. | DG(RD)&SS (Retd.), Ministry of Road Transport and Highways, New Delhi |
| 35. Subbhiya, Ravindra | Chief Design Engineer, L&T, Chennai |
| 36. Tandon, Prof. Mahesh | Managing Director, Tandon Consultants (P) Ltd., New Delhi |
| 37. Tawade, D.O. | Member (Technical) (Retd.), National Highway Authority of India (NHAI), New Delhi |
| 38. The Engineer-in-Chief, MES
(Sharma AVSM, Lt. Gen.
Suresh) | Military Engineer Service (MES), New Delhi |
| 39. Viswanathan, T | Consultant, Delhi |

Corresponding Members

- | | |
|-------------------------------|---------------------------------------------------------------------|
| 1 Manjure, P.Y. | Director, Freyssinet Prestressed Concrete Co. Ltd, Mumbai |
| 2 Sinha, Prof. Ravi | Professor, IIT Mumbai |
| 3 Subbarao, Dr. Harshavardhan | Chairman & Managing Director, Construma Consultancy (P) Ltd. Mumbai |

Ex-Officio Members

- | | |
|-----------------------------------------------------------------------------------|--------------------------------------------------------------------|
| 1 President,
Indian Roads Congress | (Basar, Toli), Chief Engineer, PWD Arunachal Pradesh |
| 2 Director General (Road
Development) & Special
Secretary to Govt. of India | (Pandey, I.K.), Ministry of Road Transport and Highways, New Delhi |
| 3 Secretary General,
Indian Roads Congress | Nirmal, Sanjay Kumar |

SECTION 2

INTRODUCTION

The Design Criteria for Prestressed Concrete Road Bridges (Post-Tensioned Concrete); IRC:18 and Standard Specification and Code of Practice for Road Bridges Section III, Cement Concrete (Plain and Reinforced); IRC:21, both based on working stress method, was first published in December 1965 and October 1966 respectively. These codes were based on linear elastic theory. The last revisions of these two WSM documents were carried out in the year 2000.

Further, considering unprecedented growth of knowledge in the field of concrete bridge technology, development of new structural forms, new methods of computer-based analysis and design and development of high strength materials, IRC decided to revise the bridge codes using the Limit State Method (LSM). Accordingly, it was decided to rationalize all Indian bridge codes, to the Limit State approach, in line with international practices. The B-4 Committee worked on this task from the year 2001 and finally the first concrete code on LSM was published in 2011. This is a unified code covering various types of concrete bridges, using plain concrete, reinforced concrete, and prestressed concrete, constructed by cast-in-place precast method. This LSM philosophy is an advancement over the traditional design philosophies. It allows us to check that the structure remains fit for use throughout its design life by remaining within the acceptable limit of safety, serviceability and durability requirements based on the risks involved.

Subsequently, IRC also published an explanatory handbook as Special Publication IRC:SP:105 with the aim to help users and provide guidance on the interpretation and use of IRC:112 along with worked-out examples. In addition, numerous special publications on subjects like Voided Slab Construction (IRC:SP:64), Segmental Bridges (IRC:SP:65), Continuous Bridges (IRC:SP:66), Use of High Performance Concrete (IRC:SP:70), Precast Pre-tensioned Girders (IRC:SP:71), were also changed to LSM philosophy and published by IRC for the use and benefit of engineers. The publication on External and Unbonded Prestressing Tendons in Bridge Structures is currently under updation to LSM (IRC:SP:67).

With the publication of this new concrete LSM code, the existing IRC:18 and IRC:21, both the working loads/allowable stress method codes have been withdrawn by IRC. However, considering the need for a smooth transition and gradual acquaintance of practicing engineers with the new LSM Code, as an alternative, the working stress method design was also allowed and was given in an annexure to IRC:112 with a rider that the option of using Annexure-4 was to be exercised by the owner, and that it would be available till it was withdrawn.

After receiving feedback on the usage of IRC:112 till 2016 from various stakeholders and also considering the policy circular of Ministry of Road Transport and Highways (MORTH) No. RW-NH-35075/9/2006-S&R (B) dated 2nd September 2016 vide which it was decided that all bridges to be constructed on National Highways, shall be designed as per IRC:112 following the 'Limit State Design Philosophy' except those components for which IRC codes and standards based on limit state approach were not available. Accordingly, Annexure-4: Structural Design by Working Loads/Allowable Stresses Method was withdrawn vide amendment No. 4 to IRC:112 was published in monthly periodical Indian Highways in August 2017.

Subsequently, numerous feedbacks/suggestions were received from practicing engineers, designers, users, etc and rapid development has been done in the field of concrete technology, other construction material. Subsequently about 21 numbers of major amendments, and editorial errata were notified from time to time till the year 2019. As the practicing engineers found it difficult to cope up with these amendments, it was decided to bring out the revised edition of IRC:112 incorporating all these amendments.

The personnel of Concrete (Plain, Reinforced and Prestressed) Structures Committee (B-4) for tenure 2018-20 is under:

Tandon, Prof. Mahesh	Convenor
Viswanathan, T.	Co-Convenor
Bhowmick, Alok	Member-Secretary

Members

Bhide, D.A.	Mullick, Dr. A.K.
Goswami, Dr. Rupen	Nagpal, Dr. A.K.
Gupta, Vinay	Parameswaran, Dr (Mrs) Lakshmy
Heggade, V.N.	Rajeshirke, Umesh
Kataria, Rajan	Rep. of BRO
Koshi, Ninan	Salecha, Aravind
Mathur, Ashok	Sharma, Aditya
Mukherjee, M.K.	Venkatram, P.G.

Corresponding Members

Joglekar, S.G.	Menon, Dr. Devdas
Kurian, Jose	Nayak, N.V.

Ex-Officio Members

President, (Basar, Toli)	DG(RD) & SS MORTH (Pandey, I.K.)
-----------------------------	-------------------------------------

Secretary General, IRC
(Nirmal, S.K.)

The BSS Committee, in its meeting held on 06.12.2019, while considering proposed amendments, also decided that the first revision of IRC:112 should be published incorporating all the proposed amendments and approved the amendments in the meeting. Thereafter, at the 219th meeting of the IRC Council held in Patna (Bihar) on 19.12.2019 while considering the proposed amendments, it was decided that the proposed amendments should also be incorporated in the print version of IRC:112 and it should published as the first revision of IRC:112. Hence this revised edition is being brought out.

This publication is meant to serve as a guide to both design and construction engineers, but compliance with the provisions therein does not relieve them, in any way, of the responsibility for the stability, soundness, durability and safety of the structures designed and constructed by them.

The design and construction of road bridges require an extensive and thorough knowledge of the science and technology involved and should be entrusted only to specially qualified engineers with adequate experience of bridge engineering, capable of ensuring correct design and execution of bridge works.

SECTION 3

DEFINITIONS AND NOTATIONS

3.1 Terms and Definitions

3.1.1 *Terms relating to structure*

Structure

Organised combination of connected parts designed to carry loads and provide adequate rigidity.

Structural Member

Physically distinguishable part of a structure, e.g. a column, a beam, a slab, a foundation pile.

Structural System

Assemblage of load-bearing members of a structure and the way in which these members function together.

Structural Model

Idealisation of the structural system used for the purposes of analysis, design and verification.

3.1.2 *Terms relating to design*

Actions

Refer 3.1.3

Resistance

Capacity of a member or component, or a cross-section of a member or component of a structure, to withstand actions without mechanical failure e.g. bending resistance, buckling resistance, tension resistance.

Strength

Mechanical property of a material indicating its ability to resist actions, usually given in units of stress, or magnitude of action.

Reliability

Ability of a structure or a structural member to fulfil the specified requirements including the design working life for which it has been designed. Reliability is usually expressed in probabilistic terms.

Design Criteria

Quantitative formulations that describe the conditions to be fulfilled for each limit state.

Design Situations

Sets of physical conditions representing the real conditions occurring during a certain time interval for which the design will demonstrate that relevant limit states are not exceeded. Refer **Annexure A-1**.

Transient Design Situation

Design situation that is relevant during a period much shorter than the design working life of the structure and which has a high probability of occurrence.

Note: A transient design situation refers to temporary conditions of use or exposure of the structure, e.g. during construction or repair.

Persistent Design Situation

Design situation that is relevant during a period of the same order as the design working life of the structure.

Note: Generally it refers to conditions of normal use.

Accidental Design Situation

Design situation involving exceptional conditions of the structure or its exposure, including fire, explosion, impact or local failure.

Seismic Design Situation

Design situation involving exceptional conditions of the structure when subjected to a seismic event.

Design Life

Assumed period for which a structure or part of it is to be used for its intended purpose with anticipated maintenance but without necessity of major repair.

Load Arrangement

Identification of the position, magnitude and direction of a free action.

Load Case

Compatible load arrangements, sets of deformations and imperfections considered simultaneously with fixed/variable actions and permanent actions for a particular verification.

Limit States

States beyond which the structure no longer fulfills the relevant design criteria.

Ultimate Limit States

States associated with collapse or with other similar forms of structural failure.

Note: These generally correspond to the maximum load-carrying resistance of a structure or structural member.

Serviceability Limit States

States that correspond to conditions beyond which specified service requirements for a structure or structural member, are no longer met.

Irreversible Serviceability Limit States

Serviceability limit states where some consequences of actions exceeding the specified service requirements will remain when the actions are removed.

Reversible Serviceability Limit States

Serviceability limit states where no consequences of actions exceeding the specified service requirements will remain when the actions are removed.

Serviceability Criterion

Design criterion for a serviceability limit state.

3.1.3 *Terms relating to actions (Also refer Annexure A-1)*

Action (*F*)

- a) Set of forces (loads) applied to the structure (direct action);
- b) Set of imposed deformations or accelerations, caused by for example temperature changes, moisture variation, uneven settlement or earthquakes (indirect action).

Effect of Action (*E*)

Effect of actions (or action effect) on structural members, (e.g. internal force, moment, stress, strain) or on the whole structure (e.g. deflection, rotation).

Permanent Action (*G*)

Action that is likely to act throughout a given reference period and for which the variation in magnitude with time is negligible, or for which the variation is always in the same direction (monotonic) until the action attains a certain limit value.

Variable Action (*Q*)

Action for which the variation in magnitude with time is neither negligible nor monotonic.

Accidental Action (*A*)

Action, usually of short duration but of significant magnitude, that may rarely occur on a given structure during the design life.

Note: An accidental action can be expected in some cases to cause severe global consequences on structures unless appropriate measures such as provision of alternative load path are taken.

Seismic Action (A_E)

Action that arises due to earthquake ground motions.

Geotechnical Action

Action transmitted to the structure by the ground, fill or groundwater.

Fixed Action

Action that has a fixed distribution and position over the structure or structural member, such that the magnitude and direction of the action are determined unambiguously for the whole structure or structural member, if this magnitude and direction are determined at one point on the structure or structural member.

Free Action

Action that may have various spatial distributions over the structure.

Single Action

Action that can be assumed to be statistically independent in time and space of any other action acting on the structure.

Static Action

Action that does not cause significant acceleration of the structure or structural members.

Dynamic Action

Action that causes significant acceleration of the structure or structural members.

Quasi-static Action

Dynamic action represented by an equivalent static action in a static model.

Characteristic Value of an Action (F_K)

Principal representative value of an action considered in the design process.

Note:

- (1) Insofar as a characteristic value can be fixed on statistical basis, it is chosen so as to correspond to a prescribed probability of not being exceeded on the unfavourable side during a 'reference period' taking into account the design working life of the structure and the duration of the design situation.
- (2) In absence of data for arriving at value as per (1), a nominal value is used which conceptually performs the same function as that of characteristic value but is not associated with any probability number.

Nominal Value

Value fixed on non-statistical bases, for instance, on acquired experience or on physical conditions, which may be used in place of characteristic value.

Reference Period

Chosen period of time that is used as a basis for assessing statistically variable actions.

Combination Value of a Variable Action ($\Psi_o Q_K$)

Value chosen, insofar as it can be fixed on statistical basis, so that the probability that the effects caused by the combination will be exceeded, is approximately the same as by the characteristic value of an individual action. It may be expressed as a determined part of the characteristic value by using a factor $\Psi_o \leq 1$.

Frequent Value of a Variable Action ($\Psi_1 Q_K$)

Value determined, insofar as it can be fixed on statistical basis, so that either the total time within the reference period during which it is exceeded, is only a small given part of the reference period, or the frequency of it being exceeded is limited to a given value. It may be expressed as a determined part of the characteristic value by using a factor $\Psi_1 \leq 1$.

Quasi-Permanent Value of a Variable Action ($\Psi_2 Q_k$)

Value of a variable action as a fraction of characteristic load, which is present for substantial part of the reference period.

Accompanying Value of a Variable Action (ΨQ_k)

Value of a variable action that accompanies the leading action in a combination.

Note: The accompanying value of a variable action may be the combination value, the frequent value or the quasi-permanent value.

Representative Value of an Action (F_{rep})

Value used for the verification of a limit state. A representative value may be the characteristic value (F_k) or an accompanying value (ΨF_k).

Design Value of an Action (F_d)

Value obtained by multiplying the representative value by the partial factor γ_f .

Combination of Actions

Set of design values used for the verification of the structural reliability for a limit state under the simultaneous influence of different actions.

3.1.4 *Terms relating to material and product properties***Characteristic Value (X_k or R_k)**

Value of a material or product property having a prescribed probability of not being attained in a hypothetical unlimited test series. This value generally corresponds to a specified fractile of the assumed statistical distribution of the particular property of the material or product. A nominal value is used as the characteristic value in some circumstances.

Design Value of a Material or Product Property (X_d or R_d)

Value obtained by dividing the characteristic value by a partial factor γ_m or γ_M , or, in special circumstances, by direct determination.

Nominal Value of a Material or Product Property (X_{nom} or R_{nom})

Value normally used as a characteristic value and established from an appropriate document.

Design Value of a Geometrical Property (a_d)

Generally a nominal value. Where relevant, values of geometrical quantities may correspond to some prescribed fractile of the statistical distribution.

3.1.5 *Terms relating to structural analysis***Structural Analysis**

Procedure or algorithm for determination of action effects in every point of a structure.

Note: A structural analysis may have to be performed at three levels using different models: global analysis, member analysis, local analysis.

Global Analysis

Determination in a structure, of a consistent set of either internal forces and moments or stresses that are in equilibrium with a particular defined set of actions on the structure, and depend on geometrical, structural and material properties.

First order linear-elastic analysis without redistribution

Elastic structural analysis based on linear stress/strain or moment/curvature laws and performed on the initial geometry of the structure.

First order linear-elastic analysis with redistribution

Linear elastic analysis in which the internal moments and forces are modified for structural design, consistent with the given external actions and without more explicit calculation of the rotation capacity.

Second order linear-elastic analysis

Elastic structural analysis based on linear stress/strain and moment/curvature laws applied to the geometry of the deformed structure.

First order non-linear analysis

Structural analysis performed on the initial geometry of the structure, that takes into account the non-linear deformation properties of materials.

Note: This definition includes first order analysis with non-linearity of any type, including plastic behaviour with or without hardening (e.g. bilinear diaphragms of stress-strain).

First order elastic-perfectly plastic analysis

Structural analysis performed on the initial geometry of the structure based on moment/curvature relationships consisting of a linear elastic part followed by a plastic part without hardening.

Second order non-linear analysis

Structural analysis performed on the geometry of the deformed structure, that takes into account the non-linear deformation properties of materials.

Second order elastic-perfectly plastic analysis

Structural analysis performed on the geometry of the displaced (or deformed) structure based on moment/curvature relationships consisting of a linear elastic part followed by a plastic part without hardening.

Elasto-plastic analysis (first or second order)

Structural analysis that uses stress-strain or moment/curvature relationships consisting of a linear elastic part followed by a plastic part with or without hardening.

Rigid Plastic Analysis

Structural analysis performed on the initial geometry of structure, that uses limit analysis theorem for direct assessment of ultimate loading.

Note: The moment-curvature law is assumed without elastic deformation and without hardening in plastic stage.

3.2 Notations

The following notations are generally used unless otherwise specified in the text or figures.

3.2.1 Latin upper case letters

A	Accidental action
A	Cross-Sectional area;
A_c	Cross-Sectional area of concrete
A_p	Area of prestressing tendon or tendons
A_s	Cross-Sectional area of reinforcement
$A_{s,min}$	Minimum cross-sectional area of shear reinforcement
A_{sw}	Cross-Sectional area of shear reinforcement
D	Diameter of mandrel
E	Effect of action or general expression for modulus of elasticity, as per the context.
E_c	Tangent modulus of elasticity of normal weight concrete at a stress of $\sigma_c = 0$.
$E_{c,eff}$	Effective modulus of elasticity of concrete
E_{cd}	Design value of modulus of elasticity of concrete
E_{cm}	Secant modulus of elasticity of concrete
$E_c(t)$	Tangent modulus of elasticity of normal weight concrete at a stress of $\sigma_c = 0$ and time t .
E_p	Design value of modulus of elasticity of prestressing steel
E_s	Design value of modulus of elasticity of reinforcing steel
E_I	Bending stiffness
E_{qu}	Static equilibrium
F	Action
F_d	Design value of an action
F_k	Characteristic value of an action
G_k	Characteristic value of a permanent action
I	Second moment of area of concrete section
L	Length
M	Bending moment
M_{Ed}	Design value of the applied internal bending moment
N	Axial force
N_{ed}	Design value of the applied axial force (tension or compression)
P	Prestressing force
P_0	Initial force at the active end of the tendon immediately after stressing
Q_k	Characteristic value of a variable action

Q_{fat}	Characteristic fatigue load
R	Resistance (also refer 3.1.4)
S	Internal forces and moments or first moment of area as per context
SLS	Serviceability limit state
T	Torsional moment
T_{Ed}	Design value of the applied torsional moment
ULS	Ultimate limit state
V	Shear force
V_{Ed}	Design value of the applied shear force
X	Refer definition in 3.1.4

3.2.2 Latin lower case letters

a	Distance
a	Geometrical data
Δa	Deviation for geometrical data
b	Overall width of a cross-section, or actual flange width in a T or L beam
b_w	Width of the web of T, I or L beams
d	Diameter; Depth
d	Effective depth of a cross-section
d_g	Largest nominal maximum aggregate size
e	Eccentricity
f_{bd}	Design value of ultimate bond stress
f_c	Compressive strength of concrete
f_{cd}	Design value of compressive strength of concrete
f_{ck}	Characteristic compressive cube strength of concrete at 28 days
f_{cm}	Mean value of compressive cube strength of concrete
f_{ctk}	Characteristic axial tensile strength of concrete
f_{ctm}	Mean value of axial tensile strength of concrete
f_p	Tensile strength of prestressing steel
f_{pk}	Characteristic tensile strength of prestressing steel which is same as f_p corresponding to breaking load given in the relevant IS codes listed in Table 18.2 .
$f_{p0,1}$	0.1% proof-stress of prestressing steel
$f_{p0,1k}$	Characteristic 0.1% proof-stress of prestressing steel
$f_{0,2k}$	Characteristic 0.2% proof-stress of reinforcement
f_t	Tensile strength of reinforcement
f_{tk}	Characteristic tensile strength of reinforcement
f_y	Yield strength of reinforcement
f_{yd}	Design yield strength of reinforcement
f_{yk}	Characteristic yield strength of reinforcement
f_{ywd}	Design yield strength of shear reinforcement

h	Height
h	Overall depth of a cross-section
i	Radius of gyration
k	Coefficient; Factor
l	(or l or L) Length; Span
l_e	Effective length
m	Mass
r	Radius
$1/r$	Curvature at a particular section
t	Thickness
t	Time being considered
t_o	The age of concrete at the time of loading
u	Perimeter of concrete cross-section, having area A_c
u, v, w	Components of the displacement of a point
x	Neutral axis depth
x, y, z	Coordinates
z	Lever arm of internal forces
n	Exponent for strain in concrete stress block

3.2.3 *Greek lower case letters*

α	Angle; ratio
β	Angle; ratio; coefficient
γ	Partial factor
γ_A	Partial factor for accidental actions A
γ_c	Partial factor for concrete
γ_F	Partial factor for actions F
γ_G	Partial factor for permanent actions G
γ_M	Partial factor for a material property, taking into account uncertainties in the material property itself, in geometric deviation and in the design model used.
γ_P	Partial factor for actions associated with prestressing P
γ_Q	Partial factor for variable actions Q
γ_S	Partial factor for reinforcing or prestressing steel
$\gamma_{S, fat}$	Partial factor for reinforcing or prestressing steel under fatigue loading
γ_f	Partial factor for actions without taking into account model uncertainties
γ_g	Partial factor for permanent actions without taking into account model uncertainties
γ_m	Partial factors for a material property, taking into account uncertainties in the material property
δ	Increment/redistribution ratio
ζ	Reduction factor/distribution coefficient
ϵ_c	Compressive strain in the concrete
ϵ_{cl}	Compressive strain in the concrete at the peak stress f_c

ε_{cu}	Ultimate compressive strain in the concrete
ε_u	Strain of reinforcement or prestressing steel at maximum load
ε_{uk}	Characteristic strain of reinforcement or prestressing steel at maximum load.
θ	Angle
λ	Slenderness ratio
μ	Coefficient of friction between the tendons and their ducts
ν	Poisson's ratio
ν	Strength reduction factor for concrete cracked in shear
ξ	Ratio of bond strength of prestressing and reinforcing steel
ρ	Oven-dry density of concrete in kg/m ³
ρ_{1000}	Value of relaxation loss (in %), at 1000 hours after tensioning and at a mean temperature of 20°C.
ρ_l	Reinforcement ratio for longitudinal reinforcement
ρ_w	Reinforcement ratio for shear reinforcement
σ_c	Compressive stress in the concrete
σ_{cp}	Compressive stress in the concrete from axial load or prestressing
σ_{cu}	Compressive stress in the concrete at the ultimate compressive strain ε_{cu}
τ	Torsional shear stress
φ	Diameter of a reinforcing bar or of a prestressing duct
φ	Sometimes used for creep coefficient without suffixes.
$\varphi_{(t,t_0)}$	Creep coefficient, defining creep between times t and t ₀ , related to elastic deformation at 28 days
$\varphi_{(\infty,t_0)}$	Final value of creep coefficient
ψ	Factors defining representative values of variable actions
ψ_o	for combination values
ψ_1	for frequent values
ψ_2	for quasi-permanent values .
η_k	Non-dimensional ratio of axial load to the capacity of concrete section (without reinforcement)

3.2.4 Physical units

The units of physical quantities are generally as per S.I. units, unless otherwise stated.

3.2.5 Mathematical Symbols and Operators

Note: Mathematical symbols and operators which are commonly used and have unique meaning are not listed. The operators and operations used in this code which have either more than one symbols or have more than one meaning for the same symbols are listed.

- | | | |
|---|---|----------------------------------------------------------------------------------------------------------------------------------------------------|
| + | - | Normally, a sign for addition. |
| | - | Also used between two (or more) events, to mean that two (or more) events are to be taken as occurring together, e.g. + used in load combinations. |

$x, *, \cdot,$	<ul style="list-style-type: none"> - When used between two (or more) quantities, means multiplication of the two (or more), e.g. $A \times B$; $A * B$; $A \cdot B$; and $A B$ or absence of any symbol
=	<ul style="list-style-type: none"> - When used in mathematical equation, shows equality of value between two sides of equation and in such cases, the dimensions expressed in length, mass and time are identical on both sides of the equation. - Also used in expression for a quantity or item, which is shown on Left Hand Side and which is expressed (or given) in the form appearing on the Right Hand Side. <p>Note: For both equation and expression, the number is given as Eq. (No.).</p>
\cong	<ul style="list-style-type: none"> - Two sides (LHS & RHS) are congruous or identical.
\approx	<ul style="list-style-type: none"> - Two sides are approximately equal.
$\%_{\infty}$	<ul style="list-style-type: none"> - Per thousand expressed in similar way as % for per cent.
$exp(*)$	<ul style="list-style-type: none"> - e raised to power (*), where e is the Natural Base (Naperian Base or Eulers number) i.e. e^*, approximately equals 2.71828.
$y = \max \{f_1; f_2; f_3 \dots\}$	Value of y becomes maximum of the values of functions of $f_1; f_2; f_3$ etc.
$y = \min \{f_1; f_2; f_3 \dots\}$	Value of y becomes minimum of the values of functions of $f_1; f_2; f_3$ etc.
Vector quantities	Vector quantities like force, strains etc. are generally not given any sign, the direction or sense (compression/tension) of which is to be understood by the context. Where a consistent sign convention is necessary, as in case of developing mathematical solutions or computerised solutions, the designer should choose appropriate and consistent sign convention.

SECTION 4

GENERAL

4.1 Scope

The Code of Practice for Concrete Road Bridges, hereinafter referred to as the ‘Code’, strives to establish common procedures for the design and construction of Concrete road bridges, foot bridges and culverts.

The requirements specified in the Code aim at achieving construction of safe, serviceable, durable and economical bridges. It covers design principles, detailed design criteria and practical rules, material specifications, workmanship, quality control and all such aspects which affect the characteristics/ability of the bridge to meet the aims.

This Code deals with the structural use of plain cement concrete, reinforced concrete, prestressed concrete and composite construction using concrete elements in bridges and is applicable to all structural elements using normal weight concrete (density in the range of $24 \pm 4 \text{ kN/m}^3$) and made using cements, aggregate, mineral admixtures, chemical admixtures and water, as given in the Section dealing with material specifications in the Code.

All provisions of the Code may not be applicable for hybrid structural systems, or for structures using other types of concrete. However, for concrete portion of hybrid elements/structures and for other type of concrete, relevant provision of this Code may be used. The term “other types of concrete” includes, but is not restricted to:

- (1) Light Weight Concrete (density $<20 \text{ kN/m}^3$) and Heavy Weight Concrete (density $>28 \text{ kN/m}^3$).
- (2) Concretes using cements, aggregates, mineral and chemical admixtures other than those covered in Section 18.
- (3) Concretes with specially modified properties.

Such uses shall be based on the specialist knowledge, specialist literature and/or experimental data at the discretion and responsibility of owners/designers.

Requirements of blast resistance and fire resistance are not covered in the Code.

4.2 Underlying Assumptions

The applicability of this document rests on the following assumptions:

- (1) The choice of structural system and the design of the structure are made by appropriately qualified and experienced personnel.
- (2) Execution is carried out by personnel having appropriate qualification, skill and experience.
- (3) Adequate supervision and quality control are provided during all stages of design and construction.
- (4) The construction materials and products are provided and used as specified by relevant national standards.
- (5) The intended levels of properties of material adopted in the design are available.
- (6) The structure is used as intended and is maintained adequately.

SECTION 5

BASIS OF DESIGN

5.1 Aims of Design

5.1.1 *General performance requirements*

The bridge, as a complete structural system and its structural elements should perform their functions adequately and safely, with appropriate degrees of reliability during design life and during construction. It should withstand all actions, consisting of applied and induced loads as well as environmental influences liable to occur, retaining its structural integrity, and also withstand accidental loads (e.g. barge impact/vehicular impact) and earthquake loads without causing damage, which is disproportionate to the causative event. Adequacy of performance is defined in terms of serviceability, safety, durability and economy.

5.1.2 *Reliability aspects and codal approach*

The term ‘degree of reliability’ is used to indicate the acceptably low level of probability of failure in meeting the expected performance during a specified period of time.

Determination of the reliability measured in terms of statistical probability requires knowledge of statistical parameters which define loading and material strengths. This data together with knowledge of structural models of resistance enable evaluation of structural performance in probabilistic terms. At the present state of knowledge, determination of reliability is possible only in limited load cases for simple structures. The Code, therefore, strives to achieve the desirable degree of reliability by approximate methods based upon a combination of the following:

- (1) Known statistical parameters describing properties of materials and actions.
- (2) Deterministic models of structural behaviour.
- (3) The international practices and past experience of acceptable/unacceptable performance of structures.
- (4) Partial factors for actions and resistance models based on calibration and rationalisation of existing international practices.

5.1.3 *Safety, serviceability, durability and economy*

The requirements of the Code directly address safety, serviceability and durability aspects.

Economy is indirectly addressed by:

- (1) Allowing maximum exploitation of materials and specifying use of technologies which are consistent with the minimum/desirable standards of safety, serviceability and durability,
- (2) Accepting appropriate levels of economic risks while specifying performance levels by taking into consideration different design situations, load combinations (events), importance of structure in view of consequences of failure, and by specifying different intended design lives for replaceable and non-replaceable parts.

5.2 Limit State Philosophy of Design

- (1) The response of the structure when subjected to different magnitudes of loads lies in different states (domains). ‘Limit States’ are defined as limits of domains beyond which the structure does not meet specified performance criteria.
In ‘Limit State Philosophy’ of design, various boundaries of acceptable/unacceptable performance are defined together with the circumstances in which such performances are expected.
- (2) Two basic groups of limit states are considered:
 - (a) **Ultimate Limit States (ULS):** These limit states cover static equilibrium and failure of structural elements or structure as a whole, when acted upon by ‘ultimate design loads’.
 - (b) **Serviceability Limit States (SLS):** These limit states deal with the condition of the structure subjected to influence of ‘serviceability design loads’. These conditions include level of internal stress, fatigue failure, deflection, damage to structural element such as cracking and discomfort to users due to vibrations.
- (3) The representative values of actions and combination of actions representing different design situations are defined. The representative values of loads are modified by using load factors for each of the basic limit states, which are then combined using combination factors. The combination factors take into account the probability of simultaneous occurrence of loads.
- (4) The response of the structure is calculated using principles of mechanics and simplified established models describing behavior of concrete members. These methods also account for inherent geometric variations which are kept within acceptable construction tolerances.
- (5) The response of the structure is required to lie within acceptable domain for different combinations of actions.
- (6) The structure designed by following this philosophy, and constructed by satisfying other stipulations of the Code are deemed to meet the general performance requirements stipulated in Clause 5.1.1.

5.3 Limit States

The structure shall be designed for the following limit states:

5.3.1 *Ultimate limit states (ULS)*

5.3.1.1 *Limit state of equilibrium*

When subjected to various design combinations of ultimate loads, the bridge or any of its components considered as a rigid body, shall not become unstable.

5.3.1.2 *Limit state of strength*

The bridge or any of its components shall not lose its capacity to sustain the various ultimate load combinations by excessive deformation, transformation into a mechanism, rupture, crushing or buckling.

5.3.2 *Serviceability limit states (SLS)*

5.3.2.1 *Limit state of internal stress*

The internal stresses developed in the materials of structural elements shall not exceed the specified magnitudes when subjected to combination of serviceability design actions. The stresses are to be estimated using resistance models to represent the behaviour of structure, as stipulated in the Code.

5.3.2.2 *Limit state of crack control*

- (1) The cracking of reinforced, partially prestressed, and prestressed concrete structures under serviceability load combinations is kept within acceptable limits of crack widths in such a way as not to adversely affect the durability or impair the aesthetics.
- (2) Alternatively, the control of cracking is deemed to be satisfied by following restrictions on amount and spacing of reinforcement.

5.3.2.3 *Limit state of deformation*

- (1) The deformation of the bridge or its elements when subjected to combination of design actions shall not adversely affect the proper functioning of its elements, appurtenances, and riding quality.
- (2) Deformations during construction shall be controlled to achieve proper geometry of finished structure.

5.3.2.4 *Limit state of vibration*

- (1) For footbridges or component of bridges specifically designed to carry footway loading, the direct verification of vibration limits is required, for which specialist literature may be referred.
- (2) For special types of bridges and their components dynamic effects under action of wind are required to be calculated and verified to be within acceptable limits. Model tests are required under certain circumstances.
- (3) For other types of bridges, the limit state of vibration under serviceability load combinations is deemed to be satisfied by limiting deflection of elements.

5.3.2.5 *Limit state of fatigue*

The bridge or any of its components shall not lose its capacity to carry design loads by virtue of its materials reaching fatigue limits due to its loading history. For carrying out fatigue verification, specialist literature may be referred.

However, fatigue verification is not necessary for the following:

- (a) For Reinforced concrete structures when the stress in the tensile reinforcement is less than 300 MPa under Rare Combination of Serviceability Limit State as against $0.8f_y$ specified in clause no. 12.2.2.
- (b) For prestressed concrete structures under the frequent combination of action and prestressing force, only compressive stresses occur at the extreme concrete fibres, under Serviceability Limit State.

5.4 Actions and their Combinations

5.4.1 Types of action

(1) An action is:

- Direct action, i.e. force (load) applied to structure.
- Indirect action, i.e. forces arising from imposed or constrained deformation, such as that caused by settlement, temperature changes, seismic acceleration and impact loads.

(2) Actions are classified:

(a) By their variation in time (duration of application) :

- Permanent Actions (G), e.g. self-weight,
- Variable Actions (Q), e.g. imposed live loads,
- Accidental Actions (A), e.g. barge impact load.

Some variable actions, acting for long durations are treated on par with permanent actions. These are called ‘Quasi-Permanent’ actions.

(b) By their nature and/or by response of the structure to them:

- Static actions are those which do not cause significant acceleration of members on which they act.
- Dynamic actions are those which cause significant acceleration of members on which they act.

Some dynamic actions can be represented by ‘Quasi-Static’ actions, which are the static values producing equivalent or representative response (stress/ deformation) in the structure caused by the dynamic action.

(3) Prestressing force (P) is a permanent action with time-dependent variation.

5.4.2 Characteristic and combinational values of actions

5.4.2.1 Characteristic value

The characteristic value of an action is generally the main representative value, which can be based upon the statistical distribution of magnitudes of action (e.g. a mean value, or upper or lower fractile value). Alternatively, a representative ‘nominal value’ is specified which is treated as a characteristic value.

A single value is generally specified, except where the design is sensitive to variation of magnitude in which case lower and upper values (also referred to as ‘inferior’ and ‘superior’ values respectively) are also specified in addition to mean value. These may be specified as absolute values or as a multiple of characteristic value.

5.4.2.2 Combinational value

(1) A structure during its construction and service life is acted upon by various direct or indirect actions at different times in different combinations, representing various design situations. Some of these situations are represented by a few combinations chosen for design checks, for which the response of the structure is calculated and verified not to exceed the limit states.

- (2) The combinational value is represented by characteristic value multiplied by a factor, which takes into account the probability of simultaneous occurrence of the most likely unfavourable values of several independent actions.
- (3) Various design situations (represented by various load combinations) for which different limit states are to be checked are given in IRC:6 and **Annexure A-1**. All components of the structure are not required to be verified for all limit states and all possible combinations. The requirements or exemptions are covered under relevant clauses of the Code dealing with such components.

5.5 Representative Values of Properties of Materials

5.5.1 *General*

The constituent materials of structure acting singly or in a composite action with other materials have certain properties which determine their own response and the behaviour of the structural elements when acted upon by various loads. Some of the material and structural properties depend upon the type of load, its duration, magnitude and the loading history. Some properties are time-dependent, while others are affected by environmental actions. Some properties depend upon the physical size (dimensions) of the structural member.

Almost all the properties exhibit statistical variation in their numerical values. Many of the properties show strong co-relations with other properties, which permit sufficiently accurate, if not exact, estimation of their value from the values of other properties by use of mathematical expressions. Correlations are based on laboratory or field observations and statistical regression analysis. A few of these properties are chosen as descriptive and/or representative properties of the materials (e.g. self compacting concrete). They are often used to define the material itself or its grade (e.g. concrete grade M40 and reinforcing steel Fe500). Standard methods of testing for measuring such values are specified by Bureau of Indian Standards or other national / international authorities.

5.5.2 *Representative values*

Depending upon the purpose of carrying out the evaluation, one or more of the following three representative values are used in the design:

- (1) Average or statistical mean value.
- (2) A lower fractile value (inferior value) based on the statistical distribution function or the statistical mean value suitably reduced by a factor.
- (3) An upper fractile value (superior value) based on the statistical distribution function or the statistical mean value suitably increased by a factor.

The representative values of commonly used materials are defined in Section 6.

5.5.3 *Other methods of assessment of properties*

When higher level of accuracy is desired in evaluating response of the structure, use of more accurate values of other properties than those obtained from co-relations used in Section 6 and **Annexure A-2** are required. In such cases, these should be based upon one of the following:

- (1) More accurate and elaborate methods/expressions which incorporate more number of factors influencing the required values reported in specialist literature from established and reliable sources.
- (2) Laboratory/field testing using standard methods of testing and measurements and based on sufficient number of tests as required by statistical methods of establishing desired accuracy (usually 95 percent confidence level). Normally, to establish mean and standard deviation, not less than 30 samples are required.

5.6 Analytical Methods to Evaluate Behaviour of Structures

5.6.1 *Global analysis of structure*

The purpose of this analysis is the verification of overall stability and establishment of effects of action on the whole or a part of the structure. These effects include the distribution of internal forces and moments as well as stresses, strains, curvatures, rotations and displacements in static or dynamic modes. To carry out analysis the geometry, boundary conditions, behaviour of the structure and its components need to be idealised. The structure is idealised by considering it as made up of elements which can be linear, two dimensional or three dimensional. Classical methods of mechanics or modern techniques such as finite element can be used for analysis. The mathematical model should be capable of evaluating the desired effect with sufficient accuracy.

5.6.2 *Local analyses*

In addition to global analysis of structure or its elements, local analyses will be necessary particularly in the regions of stress concentrations and geometric discontinuities.

5.6.3 *Idealisation, modelling and adequacy*

Behaviour of structure and its components can be represented to various degrees of accuracy. The general principles as well as normally used methods are covered in Section 7. The idealisation and modelling should be adequate to estimate the relevant action effects. The interaction of properties of constituent materials with heterogeneous properties should be appropriately taken into account.

Appropriate methods of analysis such as elastic analysis, non-elastic analysis with limited redistribution, plastic analysis with actual or idealised material properties are indicated depending upon the level of accuracy required. Necessity of including the second order effects in the analysis is indicated where it is important.

5.7 Design Based on Full Scale Testing

Design of some elements like crash barriers, fenders, prestressing anchors, etc., can be based on full scale tests of the prototype. The failure load/capacity is defined as that causing either irreparable damage, or pre-defined limit of deformation.

5.8 Durability Aspects

The durability recommendations of this Code are based on the strategies adopted regarding aspects

indicated in the following clauses. These strategic options/choices in design, detailing and construction are intended to ensure durability as well as serviceability and safety, for a period not less than the intended service life of the structure.

5.8.1 *Design life*

For design life of structures, reference may be made to provisions of IRC:5. Unless otherwise specifically classified by Owner, all structures shall be designed for a design life of 100 years.

5.8.2 *Use of appropriate values of time-dependent material properties*

Variation of strengths such as reduction of concrete strength by sustained loading as well as degradation of materials, effects of creep and shrinkage of concrete, relaxation of steel and fatigue are some of the time dependent design properties. The values of such time dependent properties to be used in the design shall take into account design service life.

5.8.3 *Specification of actions and action-effects*

For actions of environmental origin, appropriate return period is specified depending on the design life. The probability of failure during life of structure depends on the return period of load, the design life and probability of failure in unit period for the specified design value of load (unit period of one year and return period expressed in years are normally used).

5.8.4 *Control of properties of materials*

The permissible limits of known harmful elements in acceptable and durable materials are specified in Section 14.

5.8.5 *Control of attack on materials by aggressive elements under different atmospheric conditions*

Certain aggressive chemical elements in the surrounding environment such as oxygen, carbon-dioxide, sulphates and chlorides penetrate concrete and cause corrosion of steel in concrete. The moisture content in concrete and temperature directly affect the process of corrosion. The depth of penetration of these harmful elements into concrete depends on the permeability of concrete and time.

The process of deterioration is mitigated by recommending suitable materials (such as concrete having certain qualities), cover to steel, improved corrosion resistant steel, etc., for different classes of environment.

Externally applied protective barriers are indicated in certain circumstances.

5.8.6 *Maintenance*

Periodic inspection and adequate maintenance are prerequisites for ensuring durability of structure. All records of inspection and repairs should be available with concerned authority.

SECTION 6

MATERIAL PROPERTIES AND THEIR DESIGN VALUES

6.1 General

6.1.1 The analysis and design of the structure and its elements require knowledge of the physical, chemical, mechanical, load-dependent, time-dependant and process dependent properties of its materials. The properties include those governing the composite action of materials acting interactively with one another as well as acting individually. Simplified rules describing these properties which are consistent with the analysis and design models permitted by this Code are given in the following Clauses.

6.1.2 In special cases where more exact analyses and models of behaviour are to be considered, more representative rules describing these properties are needed, some of which are given in **Annexure A-2**. In addition, reference to international Codes, published literature, laboratory test reports or field tests, may also be made. However, the reliability of the referenced source and/or reproducibility of test values should be established.

6.1.3 Some of the properties are strongly influenced by activities of construction and work procedures. Use of appropriate technological methods, deployment of qualified and trained work force combined with methods of quality assurance are requisite preconditions for realising in practice the properties assumed in the design. Minimum acceptable standards of workmanship are given in Section 18.

6.1.4 Specifications of structural materials to be used in construction of bridges shall conform to the Indian Standards given in Section 18.

6.1.5 Materials conforming to other international standards can be used provided they meet the minimum requirements (lower or upper values as the case may be) given in the relevant Indian Standards and this Code.

6.2 Untensioned Steel Reinforcement

6.2.1 *Specification and grades*

Reinforcement shall consist of hot rolled, thermo-mechanical or heat-treated rods, de-coiled rods or cold worked steel of various grades given in **Table 6.1**.

Table 6.1 Grades of Reinforcing Steel

Types of Steel	Grade / Designation
Mild Steel (MS)	Grade-1
High Strength deformed Steel (HSD)	Fe415 Fe415D Fe415S Fe500 Fe500D Fe500S Fe550 Fe550D Fe600

The grade designations, definitive properties and other properties, as adopted by the relevant Indian Standards, are given in Section 18 (**Table 18.1**). The steel may be coated, or galvanised to improve its resistance to corrosion. Use of stainless steel is permitted subject to requirements stipulated in Clause 6.2.3.3.

6.2.2 Strength, stress-strain diagrams, modulus of elasticity and ductility

The minimum strength, as specified in relevant IS Standards, which is either the yield strength in case of mild steel or 0.2 percent proof strength in case of high yield strength deformed steel, is notionally taken as the characteristic strength f_{yk} .

The stress-strain diagrams of mild steel and high yield strength deformed steel are typically as shown in **Fig. 6.1 (a), (b) & (c)**, which also define various important stresses, strains and modulus of elasticity. The ductility requirements measured by ratio f_t/f_{yk} and minimum elongation are given in **Table 18.1**. The modulus of elasticity can be taken as 200 GPa for design purposes.

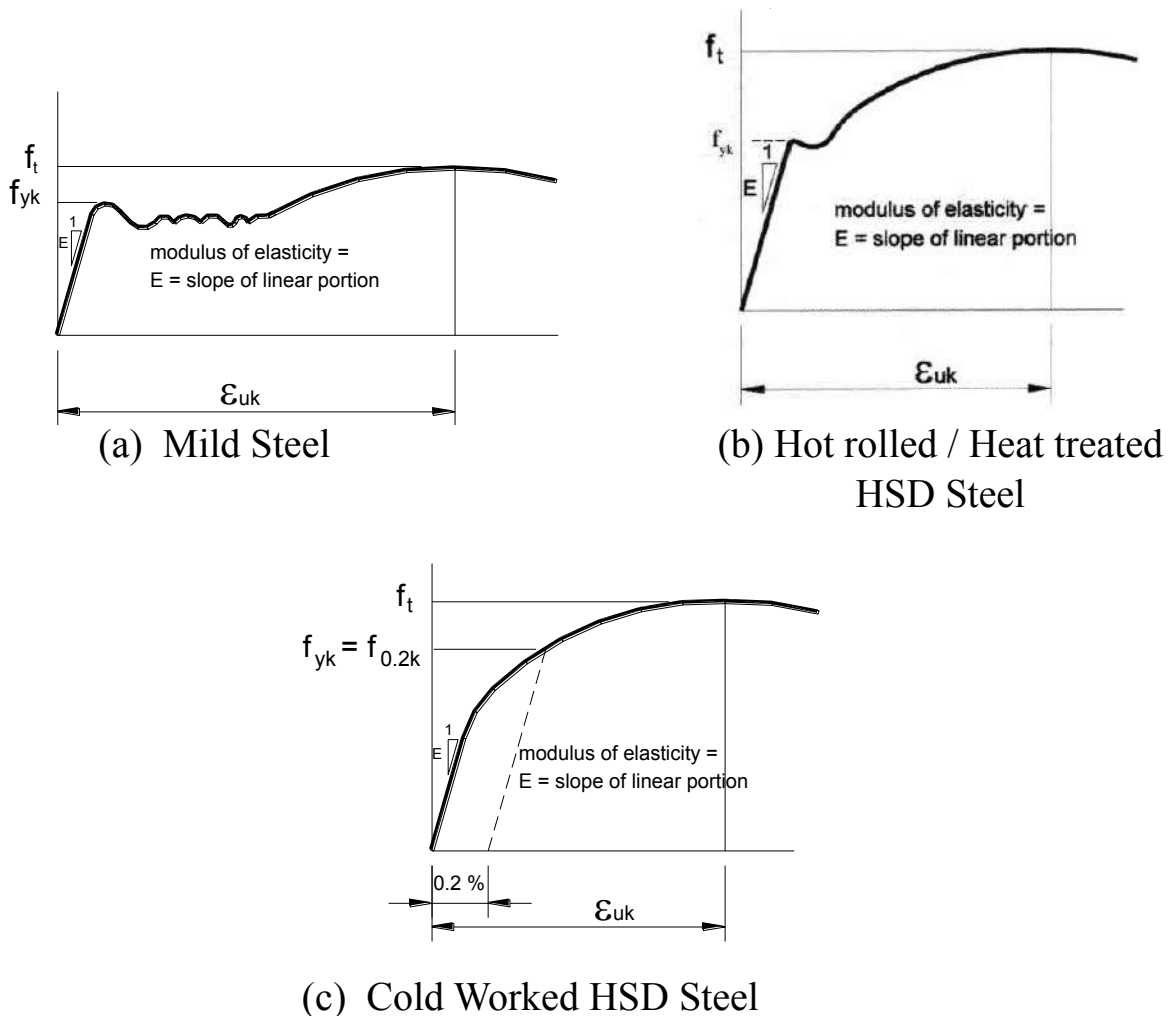
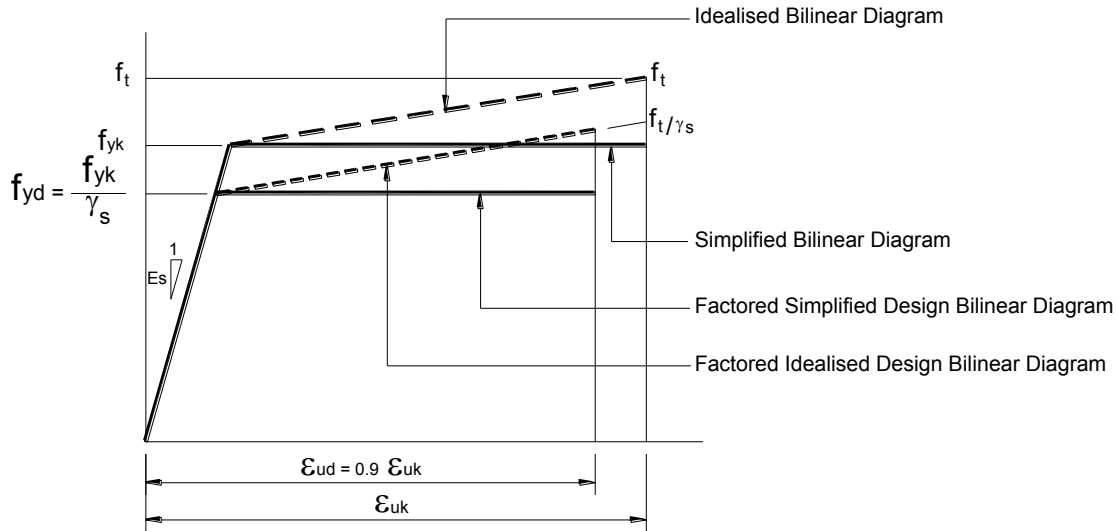

Fig. 6.1 Stress-Strain Diagram of Untensioned Reinforcement

For design purposes any one of the two diagrams, viz. idealised bilinear or simplified bilinear diagram as given in **Fig. 6.2** may be used; after reducing the stresses by material factor γ_s .



- Notes: (1) γ_s is taken as 1.15 for basic and seismic combination, and 1.0 for accidental combination
 (2) Value of ϵ_{uk} shall be taken as the uniform elongation given in the standard governing the manufacture of reinforcement.

Fig. 6.2 Bilinear Stress-Strain Diagram of Reinforcing Steel for Design

The idealised bilinear diagram has sloping top branch joining $\left(\epsilon_{yk} = \frac{f_{yk}}{E_s}; f_{yk}\right)$ and (ϵ_{uk}, f_t) , where $f_{yk}, f_t, \epsilon_{uk}$ are the minimum values required by relevant IS Codes referred to in Section 18.2.1 (**Table 18.1**). The factored idealised design diagram is obtained by factoring stress values by $\left(\frac{1}{\gamma_s}\right)$, that is by taking $f_{yd} = \frac{f_{yk}}{\gamma_s}$, and limiting design strain to $\epsilon_{ud} = 0.9\epsilon_{uk}$.

For grades Fe 415D, Fe 500D & Fe 550D, ϵ_{uk} shall be taken as 5% (max.) and for grades Fe 415S & Fe 500S, ϵ_{uk} shall be taken as 8% (max.). For other grades it shall be taken as 2.5%(max.).

6.2.3 Products with improved corrosion resistance

Reinforcing steel bars with improved corrosion resistance by any of the methods described in Section 18 can be used as reinforcement provided they meet the minimum strength, proof stress and elongation characteristics as specified in **Table 18.1**. The design properties are considered to be the same as per Clause 6.2.2 except as given in Clause 6.2.3.2 for epoxy coated reinforcement.

6.2.3.1 Galvanised reinforcement

The strength as well as elongation and bond properties of galvanised reinforcement are not adversely affected by galvanising.

6.2.3.2 Epoxy-coated reinforcement

Reinforcing bars conforming to IS:1786 can be coated by fusion bonded epoxy conforming to IS:13620.

The bond of coated reinforcement is lowered by upto 20 percent of that of uncoated reinforcement. In detailing of steel the lap length and anchorage lengths given in Section 15 should be increased by 25 percent.

6.2.3.3 *Stainless steel reinforcement*

Stainless steel reinforcement shall conform to IS:16651:2017. The code covers requirements and methods of test for high strength deformed stainless steel bars/wires of the following strength grades for use as concrete reinforcement:

- (a) SS 500,
- (b) SS 550,
- (c) SS 600, and
- (d) SS 650.

6.3 **Prestressing Steel**

6.3.1 *Specifications, grades, strength, elongation and relaxation*

Prestressing steel in the following forms, conforming to Indian Standards given in Section 18, **Tables 18.2 to 18.5** shall be used.

- Plain or indented wires
- Stress-relieved multi-ply strands
- High tensile steel bars

Steels conforming to other international standards but satisfying the minimum strength, elongation, and relaxation characteristics of Indian Standards may be used.

6.3.2 *Minimum sizes*

The steels of nominal sizes and ultimate strengths having characteristics as mentioned in **Tables 18.2 to 18.5** are permitted for use in bridges designed for 100 years.

For bridges on temporary access roads or bridges for construction facility, steels having smaller diameters than those given in the **Tables 18.3 to 18.5** but otherwise meeting the requirements of Indian Standards mentioned therein, can be used.

6.3.3 *Other properties*

6.3.3.1 *Ductility*

The requirements of ductility of steel are deemed to be satisfied by use of steel having the minimum elongations specified in Section 18, Clause 18.3.

The wires/strands shall also pass the bendability test (reverse bending) as specified in relevant Indian Standards.

6.3.3.2 *Tolerance on size/diameter*

The relevant Indian Standards specify the manufacturing tolerances on diameters/size of various products which remain valid for general acceptance of the material and the source of supply.

6.3.4 *Coated wires/strands*

The wires/strands conforming to Indian Standards can be provided with protective coatings, like galvanising or epoxy coating, carried out in specialised manufacturing units. However, if the technological processes affect any of the mechanical and physical properties, such modified properties should be taken into account in design.

6.3.5 *Stress-strain properties for design*

Typical stress/strain and ultimate elongation of prestressing wires and strands are shown in **Figs. 6.3** and **6.4**. The actual E value varies between 195 GPa and 216 GPa. For prestressing steels, the stress is to be taken as force divided by the nominal cross sectional area.

For the purpose of analysis and design, either the diagrams shown in **Fig. 6.3** or the simplified bilinear diagram as shown in **Fig. 6.4** (any one of shape A and shape B) can be used. The ‘E’ value of 200 GPa for wires and 195 GPa for strands can be used in the design up to the elastic limit (first part of bilinear diagram unless more exact value is required, e.g. for verification of elongation during stressing operations, which should be taken on the basis of actual field tests).

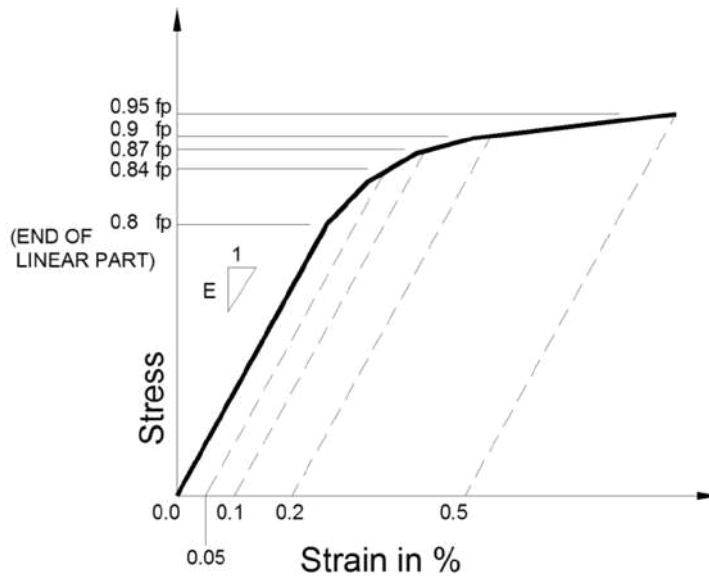

Fig. 6.3 Representative Stress-Strain Curve for Wires (Stress Relieved), Strands and Bars

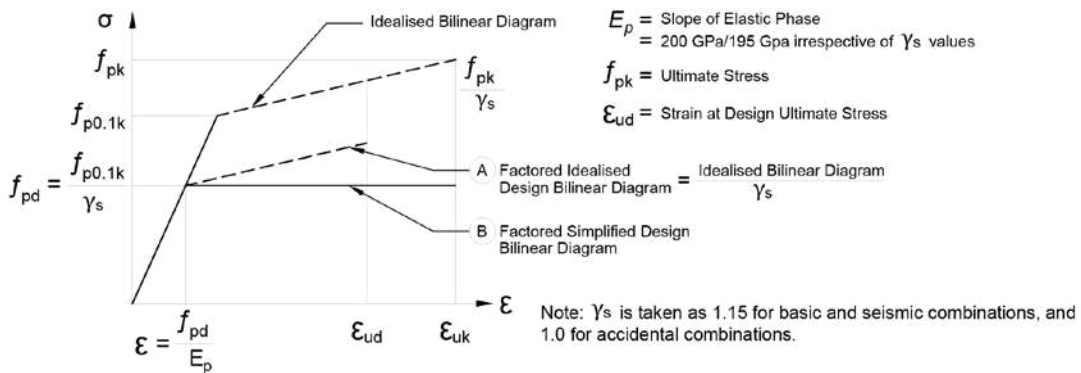

Fig. 6.4 Bi-linear Stress-strain Diagram of Prestressing Steel for Design

The idealised bilinear diagram shown in **Fig. 6.4** has sloping top branch joining $\left(\varepsilon = \frac{f_{p0.1k}}{E_p}; f_{p0.1k}\right)$ to $(\varepsilon_{uk}, f_{pk})$, where $f_{p0.1k}$ is taken from manufacturer's data, or established by tests in field. In absence of specific data, $f_{p0.1k}$ can be taken as $0.87 f_{pk}$.

For strands, stress values shall be based on the nominal cross-sectional area given in **Table 18.4**. The idealised design shape (A) is obtained by factoring idealised bi-linear diagram by $\frac{1}{\gamma_s}$, and taking design strain not greater than ε_{ud} which is equal to $0.9 \varepsilon_{uk}$ with corresponding value of design stress. ε_{ud} shall be taken as 2% (max.), if more accurate values are not available.

For simplified bilinear design diagram shape (B), having horizontal branch, the strain limit need not be checked.

6.3.6 Relaxation loss for design

In absence of actual testing, the design value of relaxation for long term losses may be taken as three times the 1000 hours value measured at initial stress of 70 percent of UTS, as specified in the relevant Codes in Section 18. For initial stress other than 70 percent of UTS, the values given in **Table 6.2** may be used.

Table 6.2 Relaxation for other Values of Initial Stress
(Expressed as percent of initial stress tested at 1000 hours at $20^\circ\text{C} \pm 2^\circ\text{C}$)

Initial Stress	Relaxation loss for Normal relaxation steel (%)	Relaxation loss for low relaxation steel (%)
$\leq 0.5 f_p$	0	0
$0.6 f_p$	2.5	1.25
$0.7 f_p$	5.0	2.5
$0.8 f_p$	9.0	4.5

For periods less than 1000 hours, the value of relaxation loss may be taken as per **Table 6.3**. For the early age relaxation in case of initial temperatures higher than 40°C , as in case of steam curing, **Annexure A-2** may be referred.

Table 6.3 Relaxation Loss Upto 1000 Hours
(As percent of 1000 hours value)

Time in Hours		1	5	20	100	200	500	1000
% loss of 1000 hrs. loss	Normal Relaxation Steel	34	44	55	70	78	90	100
	Low Relaxation Steel	37	47	57	72	79	90	100

6.4 Concrete

Cement, fine aggregates, coarse aggregates, mineral admixtures and water constitute the main material ingredients of concrete. Chemical admixtures are added to fresh concrete to improve its workability. For specification of constituents of concrete Section 18 and the relevant Indian Standards may be referred. For use of concretes designed to have special and different characteristics from those given in this Section, specialist literature may be referred.

6.4.1 Grade designation

Concrete shall be designated by type and its grade-designation based on characteristic strength as described in **Table 6.4**, where:

- (a) **Ordinary Concrete** is made on the basis of nominal mix proportioned by weight of its main ingredients - cement, coarse and fine aggregates and water.

Table 6.4 Main Groups of Concrete and its Strength-Grades

Types of Concrete/Grade Designation			Characteristic Strength in MPa
Ordinary Concrete	Standard Concrete	High Performance Concrete	
M15	M15		15
M20	M20		20
	M25		25
	M30	M30	30
	M35	M35	35
	M40	M40	40
	M45	M45	45
	M50	M50	50
		M55	55
		M60	60
		M65	65
		M70	70
		M75	75
		M80	80
		M85	85
		M90	90

Notes:

- (1) Characteristic Strength is the lower 5 percent fractile value of the statistical distribution of strength at 28 days, measured by samples prepared and tested as per Section 18.5.4, - each sample consisting of 3 cubes of 150 mm size. The grade designation is the nearest lower limit of the range in multiple of 5 MPa within which the actual characteristic strength falls.
- (2) For concretes using mineral admixtures and those using high early strength cements, the properties of setting time and time dependent strength gain are different from those of standard and ordinary concrete. Cognisance of such modified properties should be taken in deciding de-shuttering time, curing period and early age loading.

(3) Use of Strength other than 28 days Strength:

Actual strength achievable (or achieved) at other than 28 days strength, but not at more than 84 days in case of slow setting concretes, can be chosen to base the design/construction choices, if found more appropriate. This decision should be based on achievement of early/delayed strength, and the age at which the first design load, apart from the self-weight, is expected to be resisted by the structure.

(b) **Standard Concrete** is made on the basis of design mix proportioned by weight of its ingredients, which in addition to cement, aggregates and water, may contain chemical admixtures to achieve certain target values of various properties in fresh condition, achievement of which is monitored and controlled during production by suitable tests. Generally, concretes up to strength Grade M50 are included in this type.

(c) **High Performance Concrete (HPC)** is one, whose ingredients, proportions and production methods are specifically chosen to meet special performance and uniformity requirements that cannot be always achieved routinely by using only conventional materials, like, cement, aggregates, water and chemical admixtures, and adopting normal mixing, placing and curing practices. Use of mineral admixtures is required. These performance requirements can be high strength, high early strength, high workability (including Self-Compacting Concrete), low permeability and high durability for severe service environments, etc. or combinations thereof. Production and use of such concrete in the field necessitates high degree of uniformity between batches and very stringent quality control.

(d) **Self-Compacting Concrete (SCC)** is a type of High Performance Concrete, that fills uniformly and completely every corner of formwork by its own weight and fluidity without application of any vibration, without segregation, whilst maintaining homogeneity. It is suitable in situations where;

- reinforcement is very congested,
- access to allow vibration is not available,
- complicated geometry of the formwork,
- pouring is possible only from a single point,
- speedy placement is required,

It has also the other advantages of no noise due to vibration and no requirement of finishing.

6.4.2 *Design properties of concrete*

6.4.2.1 *General*

- (1) The recommended design properties are co-related to 28 days characteristic compressive strength, unless specified otherwise.
- (2) Depending on the purpose of analysis, some of the properties are used either at their mean (average) value, or at lower characteristic value or at upper characteristic value based on 5 percent fractile or 95 percent fractile respectively.
- (3) Stress-strain relationship for overall analysis of structure, stress-strain relationship for sectional design, various moduli of elasticity, Poisson's ratio, tensile strength, fracture mechanical strength, multiaxial strengths, etc., are the mechanical properties

needed for various purposes of design. Unless greater accuracy is needed justifying separate and direct testing for these characteristics, the values given in **Table 6.5** may be used in design, which are based on their relation to the compressive strength. The co-relation equations are given in **Annexure A-2**.

- (4) Some of the time-dependent behaviours of structure and time dependent effects are permitted to be evaluated by using simplified expressions, using appropriately modified values of some properties, (e.g. factored value of the modulus of elasticity to incorporate creep effects). Where greater accuracy is needed, specialist literature or relevant international codes may be referred.

- (5) Relationship between Strength and Time:

The development of compressive strength of concrete depends on the type of cement, curing conditions and maturity of concrete. Maturity is measured as a sum of the product of time and mean temperature of concrete, measured in appropriate units as given below:

Maturity in day Celsius or hour Celsius = \sum time in days (or hours) x (temperature in °C+11°C). **Eq. 6.1**

In normal applications instead of the exact strength-maturity relationship simplified strength-time relationship is used, with limits of validity as given in Clause 6.4.2.2. For special applications, where temperature history deviates from the limits given, **Annexure A-2** may be referred.

6.4.2.2 Compressive strength and strength development with time

- (1) Relationship connecting age in days to strength given by Eq. 6.2 and Eq. 6.3 can be used in place of strength-maturity relationship, which are valid for seasonal variation of temperature between (-)20°C to (+)40°C.

$$f_{cm}(t) = \beta_{cc}(t) f_{cm} \quad \text{Eq. 6.2}$$

$$\beta_{cc}(t) = \exp \left\{ S \left[1 - \left(\frac{28}{t/t_1} \right)^{1/2} \right] \right\} \quad \text{Eq. 6.3}$$

where

$f_{cm}(t)$ = Mean concrete compressive strength at age 't' days.

f_{cm} = Mean concrete compressive strength at age '28' days.

$\beta_{cc}(t)$ = Co-efficient depending on age 't' and type of cement.

t = Age of concrete in days.

t_1 = 1 day

S = Co-efficient whose value is taken as 0.25 for Ordinary Portland cement. Refer **Annexure A-2** for other cements.

Effect of substantial temperature deviation in the range of 0°C to 80°C (for example in steam curing), is to be included by substituting equivalent time (t_p) in place of time 't' at 20°C in Eq. 6.2 & 6.3. The expression for equivalent time t_p is given in **Annexure A-2**.

TABLE 6.5 Stress and Deformation Characteristics for Normal Concrete

Strength Classes for Concrete																
Strength class	M 15	M 20	M 25	M 30	M 35	M 40	M 45	M 50	M 55	M 60	M 65	M 70	M 75	M 80	M 85	M 90
1 f_{ck} (MPa)	15	20	25	30	35	40	45	50	55	60	65	70	75	80	85	90
2 f_{cm} (MPa)	25	30	35	40	45	50	55	60	65	70	75	80	85	90	95	100
3 f_{cm} (MPa)	1.6	1.9	2.2	2.5	2.8	3.0	3.3	3.5	3.7	4.0	4.4	4.5	4.7	4.8	4.9	5.0
4 $f_{ctk,0.05}$ (MPa)	1.1	1.3	1.5	1.7	1.9	2.1	2.3	2.5	2.6	2.8	2.9	3.0	3.1	3.2	3.3	3.3
5 $f_{ctk,0.95}$ (MPa)	2.0	2.5	2.9	3.2	3.6	3.9	4.3	4.6	4.9	5.2	5.4	5.6	5.7	5.9	6.1	6.2
6 E_{cm} (GPa)	27	29	30	31	32	33	34	35	36	37	38	38	39	40	40	41
7 ϵ_{c1} (‰)	1.8	1.9	2.0	2.0	2.1	2.2	2.3	2.3	2.4	2.4	2.5	2.5	2.6	2.6	2.7	2.7
8 ϵ_{cu1} (‰)	3.5										3.4	3.2	3.0	2.9	2.9	2.8
9 ϵ_{c2} (‰)	2.0										2.1	2.2	2.3	2.3	2.4	2.4
10 ϵ_{cu2} (‰)	3.5										3.3	3.1	2.9	2.8	2.7	2.6
11 n	2.0										1.9	1.7	1.6	1.5	1.5	1.4
12 ϵ_{c3} (‰)	1.8										1.8	1.8	1.9	1.9	2.0	2.1
13 ϵ_{cu3} (‰)	3.5										3.3	3.1	2.9	2.8	2.7	2.6

Notes:

- (1) Strength designation of concrete, (based on characteristic strength) and corresponding properties to be used in the design are given above. The strains are expressed in per thousand by ‰ sign. The co-relation equations used are given in **Annexure A-2**.
- (2) The tabulated values of E_{cm} are for quartzite/granite aggregates. For other aggregates, they should be multiplied by factors as given below:
limestone = 0.9, sandstone = 0.7, basalt = 1.2.
- (3) Properties of materials to be used in bridge construction given in Section 18 and the acceptance criteria based on sampling theory of statistics are to be used for procurement purposes only.

(2) Effect of sustained loading and gain of strength with time

Although concrete gains strength with age due to continued chemical reactions, it also exhibits reduction of strength under the effect of sustained loading. This long term effect together with effect of the size of the structural element is taken into account while recommending design values of strength in this Code e.g. long term compressive strength in-structure is taken as 0.67 times of 28 days cube strength. (It is directly incorporated in formula for ultimate bending strength).

(3) Verification of early age strength by testing

To avoid irreversible damages like local cracking (eg. due to early age prestressing) the achievement of early age strength shall be verified by testing. Refer Section 18 for details.

(4) Use of strengths beyond 28 days strength

Gain of strength beyond 28 days should not be considered in new designs except as per Note No.3 below **Table 6.4**. For evaluation of strength/load carrying capacity of old existing bridges and for retrofitting purposes, strength at ages other than 28 days can be used after making allowance for age, sustained load effect, state of cracking and fatigue effects, for which specialist literature may be referred.

6.4.2.3 Tensile strength & strength development with time

(1) Direct tensile strength

The tensile strength is the highest tensile stress reached under concentric loading. The tensile strength of concrete f_{ctm} is difficult to measure directly and hence is measured either by splitting cylinders/cubes under transverse strip loading, or by flexural tensile test of standardised beams obtained following standard test procedures.

The relation between mean tensile strength f_{ctm} , split cylinder strength and beam test are given in Eq.6.4 and Eq.6.5.

For standard 300 mm dia. cylinder tested as per IS 5876

$$f_{ctm} = 0.9 f_{ct,split.cyl} \quad \text{Eq. 6.4}$$

where

$$f_{ct,split.cyl} = \text{mean value of cylinders tested}$$

For standard beam sizes tested as per IS:516

$$f_{ctm} = \begin{cases} 0.6 f_b & \text{for beam size of 100 x 100 x 400 mm and} \\ 0.66 f_b & \text{for beam size of 150 x 150 x 600 mm} \end{cases} \quad \text{Eq. 6.5}$$

where

$$f_b = \text{modulus of rupture measured as per IS 516.}$$

(2) Co-relation to the 28 days cube compressive strength

In absence of tensile tests, the values of tensile strengths f_{ctm} given in **Table 6.5** can be adopted.

(3) Flexural tensile strength for other sizes

The mean flexural tensile strength in solid beams depends on the mean axial tensile strength f_{ctm} and the depth of the cross-section. The following relationship may be used:

$$f_{ctm,fl} = \max. \left\{ \left(1.6 - \frac{h}{1000} \right) f_{ctm}; f_{ctm} \right\} \quad \text{Eq. 6.6}$$

where

$$f_{ctm,fl} = \text{mean flexural tensile strength of solid beam.}$$

$$h = \text{total depth of member in mm}$$

$$f_{ctm} = \text{mean axial tensile strength from **Table 6.5**}$$

The relation given in Eq. 6.6 also applies for the characteristic tensile strength values.

(4) Direct tensile strength for use in elements fully in tension

For members fully in tension, having more or less uniform tension (like bottom/top slabs of box girders) $f_{ctk,0.05}$ given in **Table 6.5** may be used.

(5) Strength gain with time

(a) The development of tensile strength with time is strongly influenced by curing and drying conditions as well as by the dimensions of the structural members. As a first approximation it may be assumed that the tensile strength :

$$f_{ctm(t)} = (\beta_{cc}(t))^\alpha f_{ctm} \quad \text{Eq. 6.7}$$

where

$\beta_{cc}(t)$ follows from Eq. (6.3)

$$\alpha = 1 \text{ for } t < 28 \text{ days}$$

$$\alpha = 2/3 \text{ for } t \geq 28 \text{ days}$$

The design values for f_{ctm} are given in **Table 6.5**.

- (b) Where the development of the tensile strength with time is important (e.g. for control of cracking) it is recommended that tests are carried out taking into account the exposure conditions and the dimensions of the structural member.

6.4.2.4 Multi-axial state of stress

The multi-axial compressive strength of concrete is higher than the uni-axial compressive strength. Normally, in bridge structures, this higher strength does not contribute significantly to design of main elements. However, in design of local zones, the increased strength is made use of (e.g. near concentrated loads, in design of concrete hinges and anchorage zones of prestressing anchorages). **Annexure A-2** and specialist literature may be referred for the relevant design properties.

6.4.2.5 Stress-strain relationship and modulus of elasticity

- (1) The stress-strain relationship of concrete in compression and tension exhibits non-linearity and time-dependent changes. It also depends upon the rate of loading and loading history, creep and shrinkage. The contribution of creep to total strain is different at loading and unloading stages.
- (2) In general terms, the total strain of concrete at time t subjected to sustained loading from initial loading at time t_0 is given by:

$$\varepsilon_c(t) = \varepsilon_{cs}(t) + \varepsilon_{cn}(t) = \varepsilon_{ci}(t_0) + \varepsilon_{cc}(t) + \varepsilon_{cs}(t) + \varepsilon_{cT}(t) \quad \text{Eq. 6.8}$$

where

$\varepsilon_{ci}(t_0)$ = is the initial strain at loading.

$\varepsilon_{cc}(t)$ = is the creep strain at time $t > t_0$

$\varepsilon_{cs}(t)$ = is the shrinkage strain

$\varepsilon_{cT}(t)$ = is the thermal strain

$\varepsilon_{cs}(t)$ = is the stress dependent strain: $\varepsilon_{cs}(t) = \varepsilon_{ci}(t_0) + \varepsilon_{cc}(t)$

$\varepsilon_{cn}(t)$ = is the stress independent strain: $\varepsilon_{cn}(t) = \varepsilon_{cs}(t) + \varepsilon_{cT}(t)$

The creep co-efficient $\phi(t, t_0)$ is defined as the ratio of creep strain at time (t) and initial elastic strain.

$$\phi = \phi(t, t_0) = \frac{\varepsilon_{cc}(t)}{\varepsilon_{ci}(t_0)} \quad \text{Eq. 6.9}$$

The shrinkage and creep strains are to be estimated as given in Clauses 6.4.2.6 and 6.4.2.7.

- (3) However, for the purpose of analysis of overall structure under normal temperature variations and its response to loads for static, equivalent static or linear dynamic response

to earthquake loads, approximate simplified values given in this Code are adequate. Where greater accuracy is desired and for non-linear elastic analysis **Annexure A2** and specialist literature should be referred.

- (4) The load-deformation characteristics of structure are dependent on duration of load, age at loading and stress level up to which the material of the structure is loaded. These are calculated by use of appropriate modulus of elasticity as under:
- (i) For static and quasi-static loads acting for short duration, secant modulus of elasticity of concrete E_{cm} , (slope of line connecting the origin of stress/strain diagram to $0.33 f_{cm}$) may be used. Values of E_{cm} are given in **Table 6.5** for different grades of concrete.
 - (ii) The Poisson's ratio for uncracked concrete may be taken as 0.2 and that for cracked concrete as zero.
 - (iii) In general, the effects of long term loading (due to creep) shall be obtained separately and added to those obtained from short term analysis. As a simplification for the overall analysis of structure (not for local analysis), the value of E_{cm} can be modified by a factor $\frac{1}{1+\phi}$ accounting for long term creep effects where ϕ is the creep coefficient defined by Eq. 6.9 and **Table 6.9**.
 - (iv) For calculating creep effects of shorter duration, either separate analysis should be done or E_{cm} can be modified by factor consistent with the creep of the same duration.
 - (v) The effect of shrinkage shall be separately calculated and added. It is taken as part of dead load analysis.
 - (vi) For calculating effects of seasonal temperature variation, value of 0.5 times E_{cm} may be used to account for temperature induced stresses as modified by creep effects. For diurnal variation of temperatures, value of E_{cm} may be used.
 - (vii) For elastic analysis of structure under dynamic loads (such as earthquake, wind etc where structures are not permitted to enter overall plastic range), E_{cm} given in **Table 6.5** may be used.
 - (viii) For resistance to impact/shock loading dynamic modulus of elasticity can be taken as 1.25 times E_{cm} in absence of tests.
 - (ix) For non-linear analysis, suitable techniques for representing non-linearity of material properties shall be used for which **Annexure A-2** and/or specialist literature may be referred.
 - (x) Effect of early age loading on E_{cm}
Variation of modulus of elasticity with time (t) is given by Eq. 6.10. Relationship between $f_{cm(t)}$ and f_{cm} is given by Eq. 6.2 and Eq. 6.3.
$$E_{cm(t)} = \left(\frac{f_{cm(t)}}{f_{cm}} \right)^{0.3} E_{cm} \quad \text{Eq. 6.10}$$
 - (xi) For loading beyond 28 days, increase in E_{cm} is small and can normally be neglected.

6.4.2.6 Shrinkage

- (1) The total shrinkage of concrete depends upon the constituents of concrete, size of the member and environmental conditions. For a given humidity and temperature, the total shrinkage of concrete is most influenced by the total amount of water present in the concrete at the time of mixing and to a lesser extent, by the cement content.
- (2) The total shrinkage strain is composed of two components, the autogenous shrinkage strain and the drying shrinkage strain.

The value of the total shrinkage strain ε_{cs} is given by :

$$\varepsilon_{cs} = \varepsilon_{cd} + \varepsilon_{ca} \quad \text{Eq. 6.11}$$

where

ε_{cs} is the total shrinkage strain

ε_{cd} is the drying shrinkage strain

ε_{ca} is the autogenous shrinkage strain

- (3) The major part of the autogenous shrinkage strain develops during hardening of the concrete in the early days after casting. Autogenous shrinkage can be taken as a function of the concrete strength. It should be considered specifically when new concrete is cast against hardened concrete.

In absence of accurate field/laboratory data, the values given in **Table 6.6** may be considered in design:

Table 6.6 Autogenous Shrinkage Strain of Concrete

Grade of Concrete	M30	M35	M45	M50	M60	M65
Autogenous Shrinkage Strain $\varepsilon_{ca} \times 10^6$	35	45	65	75	95	105

- (4) The drying shrinkage strain develops slowly, since it is a function of the migration of water through the hardened concrete.

The final value of the drying shrinkage strain, $\varepsilon_{cd\infty}$ may be taken equal to $k_h \cdot \varepsilon_{cd}$ where k_h and ε_{cd} are taken from **Tables 6.7 & 6.8**.

(These are expected mean values, with a coefficient of variation of about 30 percent).

where

k_h is a coefficient depending on the notional size h_o :

h_o is the notional size (mm) of the cross-section = $2A_c/u$

where

A_c is the concrete cross-sectional area.

u is the perimeter of that part of the cross-section which is exposed to drying.

Table 6.7 Values for K_h

h_o in mm	k_h
100	1.0
200	0.85
300	0.75
≥ 500	0.70

**Table 6.8 Unrestrained Drying Shrinkage Values ($\epsilon_{cd} \times 10^6$)
(for concrete with Portland cement)**

f_{ck} (MPa)	Relative Humidity (in %)		
	20	50	80
25	620	535	300
50	480	420	240
75	380	330	190
95	300	260	150

- (5) The development of autogenous shrinkage with time can be taken as:

$$\epsilon_{ca}(t) = \beta_{as}(t) \epsilon_{ca} \quad \text{Eq. 6.12}$$

where

$$\beta_{as}(t) = 1 - \exp(-0.2\sqrt{t}) \quad \text{Eq. 6.13}$$

where t is in days

- (6) The development of the drying shrinkage strain in time can be taken as:

$$\epsilon_{cd}(t) = \beta_{ds}(t, t_s) k_h \cdot \epsilon_{cd} \quad \text{Eq. 6.14}$$

$$\beta_{ds}(t, t_s) = \frac{(t - t_s)}{(t - t_s) + 0.04\sqrt{h_0^3}} \quad \text{Eq. 6.15}$$

where

t = is the age of the concrete in days at the time considered

t_s = is the age of the concrete in days at the beginning of drying shrinkage. Normally this is at the end of curing.

k_h = from **Table 6.7**.

6.4.2.7 Creep

- (1) Creep of concrete depends, on the stress in the concrete, age at loading and duration of loading in addition to the factors listed in Clause 6.4.2.6(1). As long as the stress in concrete does not exceed $0.36 f_{cm}(t_o)$, creep may be assumed to be proportional to the stress.

(2) The creep co-efficient $\phi = \frac{\varepsilon_{cc}(t)}{\varepsilon_{ci}(t)}$
where

$\varepsilon_{cc}(t)$ is creep strain at time $t > t_0$

$\varepsilon_{ci}(t)$ is initial strain at loading.

The values given in **Table-6.9** can be considered as final creep co-efficient for design for normal weight concrete, subject to condition that the compressive stress does not exceed $0.36 f_{cm}$ at the age of loading. In case the compressive stress exceeds $0.36 f_{cm}$, at loading, non-linear creep shall be considered.

Table 6.9 Final Creep Co-efficient [ϕ (70 Yr)] of Concrete
at age of $t = 70$ years or more

Age at loading t_0 (days)	Notional Size $2A_c/u$ (in mm)					
	50	150	600	50	150	600
	Dry atmospheric conditions (RH – 50%)			Humid atmospheric conditions (RH – 80%)		
1	6.00	4.95	4.05	3.95	3.50	3.15
7	4.20	3.45	2.85	2.75	2.45	2.20
28	3.20	2.65	2.20	2.10	1.90	1.70
90	2.60	2.10	1.75	1.75	1.50	1.35
365	2.00	1.60	1.30	1.30	1.15	1.05

Note

- The above table is applicable for M35 grade concrete. For lower grade of concrete the coefficient may be multiplied by $\sqrt{\frac{45}{f_{cm}}}$
- For higher grades of concrete the coefficient may be worked out using equations given in **Annexure A-2**. For simplification however, the values given in the **Table 6.9** can also be adopted for higher grades.
- Relative humidity mentioned in **Table 6.9** is defined as average annual relative humidity (RH) of the atmosphere.
Annexure A-7 which shows the maximum and minimum value of relative humidity may be referred to. The mean of the values corresponding to a respective station as shown in **Table A-7** shall be used as average annual relative humidity.
For bridge locations other than the stations given in **Table A-7**, values corresponding to nearest station shall be used.
- The development of creep with time may be taken as
$$\phi(t, t_0) = \beta(t, t_0) \cdot \phi(\infty, t_0)$$

Eq. 6.16

where

$$\beta(t, t_0) = \left[\frac{t - t_0}{\beta_H + (t - t_0)} \right]^{0.3} \quad \text{Eq. 6.17}$$

where

t is the age of concrete in days at the time considered.

t_0 is the age of concrete in days at time of loading.

$(t - t_0)$ is the actual duration of loading in days.

β_H is a coefficient depending on the relative humidity (RH in percent) and the notional member size (h_0 in mm). It may be estimated from:

$$\beta_H = 1.5 \left[1 + \left(1.2 \frac{RH}{RH_0} \right)^{18} \right] h_0 + 250 \leq 1500 \text{ for } f_{cm} \leq 45 \quad \text{Eq. 6.18}$$

$$\beta_H = 1.5 \left[1 + \left(1.2 \frac{RH}{RH_0} \right)^{18} \right] h_0 + 250\alpha \leq 1500\alpha \text{ for } f_{cm} \geq 45 \quad \text{Eq. 6.19}$$

where

RH = Relative humidity expressed as percent.

RH_0 = 100 (i.e. 100 percent)

α = is coefficient to consider the influence of the concrete strength:

$$\alpha = \left[\frac{45}{f_{cm}} \right]^{0.5} \quad \text{Eq. 6.20}$$

f_{cm} in MPa

Where 45 in numerator and f_{cm} in denominator has units of MPa.

h = Notional size of member in mm = $\frac{2A_c}{u}$

A_c = Cross Sectional Area in mm².

u = Perimeter in contact with atmosphere in mm.

- (4) Where greater accuracy is required in estimating $\phi(t, t_0)$, **Annexure A-2** and/or the specialist literature may be referred.

6.4.2.8 Stress-strain relation for design of sections

(1) Unconfined concrete

(a) Parabolic rectangular stress-strain block

For design of section, the following relationship may be used as shown in **Fig. 6.5**.

$$\sigma_c = f_{cd} \left[1 - \left(1 - \frac{\varepsilon_c}{\varepsilon_{c2}} \right)^n \right] \text{ for } 0 \leq \varepsilon_c \leq \varepsilon_{c2} \quad \text{Eq. 6.21}$$

$$\sigma_c = f_{cd} \text{ for } \varepsilon_{c2} \leq \varepsilon_c \leq \varepsilon_{cu2}$$

Eq. 6.22

where

n = Exponent as given in **Table 6.5**

ε_{c2} = Strain at reaching characteristic strength as given in **Table 6.5**

ε_{cu2} = Ultimate strain as given in **Table 6.5**

$$f_{cd} = \frac{\alpha f_{ck}}{\gamma_m}$$

where

$$\alpha = 0.67$$

$\gamma_m = 1.5$ For Basic & Seismic Combination

= 1.2 for Accidental Combination

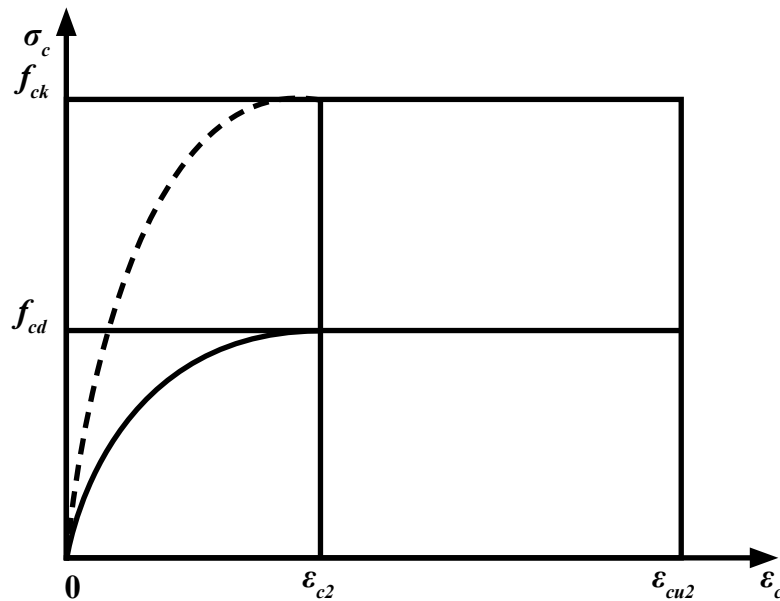

Fig 6.5 Parabolic-Rectangular Diagram for Concrete in Compression for Design of Sections

(b) Other simplified equivalent stress blocks

The parabolic rectangular stress-strain block described in (a) above is of general validity for all design situations. However, simplified equivalent stress blocks such as rectangle or bilinear may be used for design purposes where the net results are sufficiently accurate. Refer **Annexure A-2** for details.

(2) Confined concrete

Confinement of concrete results in higher strength and higher critical strains. As a result stress-strain relationship is modified. The other basic material characteristics may be considered as unaffected for design. Refer **Annexure A-2** and/or specialist literature for details.

SECTION 7

ANALYSIS

7.1 General Provisions

7.1.1 *Response of structure to loads*

The purpose of structural analysis is the verification of overall stability and establishment of action effects on the whole or a part of the structure. These effects include the distribution of internal forces and moments as well as the calculation of stresses, strains, curvatures, rotations and displacements in static or dynamic modes. To carry out analysis, the geometry, boundary conditions and behaviour of the structure will need to be idealized both for global and local behaviour. The structure is idealised by considering it as made up of elements which can be linear, two dimensional or three dimensional. Classical methods of mechanics or modern techniques such as finite element may be used for analysis depending upon the suitability of the mathematical model to evaluate the action effects with sufficient accuracy.

Since concrete is a heterogeneous material, its properties are not independent of the size of the member. These are also time dependent. For reinforced and prestressed concrete elements the structural behaviour depends on the location and amount of steel as well as the state of deformation and cracking of the element, which in turn, depends upon the level of load. In the analysis, appropriate simplified values of properties of constituent materials and properties representing composite action (e.g. bond) are made in order to represent the behaviour of these elements. The range of validity of these simplified properties and the level of accuracy in predicting the structural behaviour by analytical methods, has to be taken into account in the design process.

The in-service behaviour of structural elements as well as their ultimate strengths and modes of failure are determined by the material properties, load resisting mechanism of the structural elements and, the combined effects of axial forces, bending moments, transverse shears, in-plane shears and torsions. The interdependency of various strengths of a member; such as axial, bending, shear and torsion, has been established both by theory and by experiments. However, in most cases of practical design, bending combined with axial forces and shear combined with torsion are treated separately. In this approach, the design models used in different load resisting mechanisms are not completely compatible. Design of columns, beams and slabs are typically based on this approach. For elements having complex geometry – such as shells - and for some local zones of the elements (refer Clause 7.1.2.2) design has to be based on the net effect of all forces acting together, ensuring compatibility of strains. Suitable model representing the element and appropriate method of analysis have to be used in the design process.

7.1.2 *Methods of analyses*

7.1.2.1 *General*

In terms of the behaviour of the structure, the following methods of analysis may be used:

- (1) Linear elastic analyses for both static and dynamic response

- (2) Linear elastic analyses with limited redistribution of forces for static response
- (3) The ‘Strut and Tie’ method for achieving internal equilibrium within the elements in conjunction with overall elastic analysis of the structure, where stiffness of the structural elements is based on assumptions (a) or (b) as described in Clause 7.2(1).
- (4) Non-linear analyses, (material and/or geometric non-linearity) for both static and dynamic response.

The solutions based on failure mechanisms of structure or plastic behaviour of elements shall not be used in design of bridges; except for the case of analysing response to earthquake. This shall be done only after adequate investigation of all significant modes of failure.

7.1.2.2 *Local analyses*

In addition to global analyses of structure or its components, local analyses may be necessary, particularly where,

- (1) Significant and rapid changes in stresses and strains in a particular region of the structure/component are involved (e.g. regions around openings, junctions of elements).
- (2) Local non-linear behaviour needs to be analysed, (e.g. locally near supports/bearings, formation of hinges).
- (3) Assumption of linear strain distribution is not valid. (e.g. thick sections, deep beams, corbels, anchorage zones).

Where local effects are calculated separately, independent of global effects, the effects shall be combined.

7.1.3 *Second order effects*

- (1) Second order effects are the additional effects caused by structural deformations, e.g. P- Δ effect for column.
- (2) Second order effects shall be considered in the analysis where they are likely to affect overall stability or the attainment of the ultimate limit state at critical sections, (e.g. buckling of slender members, redistribution of forces due to creep of concrete, settlement of supports in indeterminate structure).

7.1.4 *Modelling of foundations*

Structural elements transferring loads to the foundation strata can be treated as rigid or flexible depending on their stiffness with appropriate end conditions. Settlement effects are to be treated as independent loading conditions. Where soil-structure interaction is considered as significantly influencing the behaviour of the structure, the foundation and stratum shall be appropriately modelled (e.g. by use of appropriate springs).

7.1.5 *Redistribution of moments*

Redistribution of moments obtained by rigorous elastic analysis may be carried out provided:

- (1) Reduction at one location is accompanied by increase in other location in such a way as to maintain equilibrium with applied loads.

- (2) Reduction is restricted to not more than 15 percent of the maximum moment in SLS and 20 percent of that in ULS.

Redistribution shall not be carried out in circumstances where the rotation capacity and the section to which the redistributed moments are to be transferred, cannot be defined (e.g. in curved bridges and skew bridges with more than 15° angle of skew).

7.1.6 *Non-linear analyses*

Non-linearity of material stress-strain relationship is taken into account for design of sections.

Non-linearity arising from member's response (e.g. due to cracking, creep etc.) is considered in calculating the deflections.

Non-linearity due to formation of plastic hinges in linear members or yield lines in two dimensional elements, is not permitted except for demonstrating non-collapse condition in seismic event or impact loading.

7.1.7 *Plastic analysis*

- (1) Methods based on lower bound plastic solutions may be used provided appropriate measures are taken to ensure that ductility conditions are satisfied.
- (2) Elements may be idealised as statically determinate trusses consisting of straight notional struts (carrying the compressive forces in the concrete) and ties (the reinforcement). The forces in the members of the truss are established from considerations of equilibrium. Sufficient reinforcement is then provided to carry the tension in the ties and a check is performed to ensure that the compressive stresses in the struts are not excessive. Detailing requirements should then be checked, with particular regard to anchorage of all reinforcement and to local bearing stresses due to concentrated forces.
- (3) The location and orientation of the struts and ties should reflect approximately the distribution of internal forces resulting from an elastic analysis of the member.
- (4) In checking compressive stresses in the struts, consideration should be given to a possible reduction in strength due to transverse tensile stresses or cracking or the influence of shear. The average design compressive stress in the struts may be taken as νf_{cd} . In the absence of other data, ν may be taken as 0.6, including an allowance for sustained loading. Higher values for ν (even $\nu > 1$) may be justified based on a triaxial state of compressive stress, provided it can be shown that the complementary transverse compression can be realised in practice.
- (5) The design stress in the ties is limited to f_{yd}
- (6) Detailing should comply with Sections 15 & 16.

7.2 Analyses for Serviceability Limit States

- (1) Elastic methods of analysis should be used to determine internal forces and deformations. The stiffness constants of discrete members or unit widths of slab elements may be based on any of the following:

- (a) **Concrete Section:** The entire cross-section of member, ignoring the presence of reinforcement.
- (b) **Gross Transformed Section:** The entire cross-section of member including the reinforcement transformed on the basis of effective modular ratio, $E_s/E_{c,eff}$

A consistent approach should be used to reflect the behaviour of various parts of the structure.

- (2) For limit state checks of deformation, stresses and crack control of beams having wide compression flanges, a constant effective width should be used over the full span while working out the sectional properties. (Refer Clause 7.6.1.2). Where greater accuracy is required variation in the effective width along the spans should be considered.
- (3) Modulus of elasticity and shear modulus of concrete should be appropriate for the type of action under consideration.
- (4) For verification of steel stresses and control of cracks in discontinuity zones, strut-and-tie model as adopted in the ULS design may be used.

7.3 Analyses for Ultimate Limit States

- (1) Elastic methods may be used to determine the distribution of forces and deformations throughout the structure. Stiffness constants based on the section properties as used for the analysis of the structure at the serviceability limit state, may be used in the analysis.
- (2) In seismic analysis, plastic methods of analysis may be used provided it can be shown that adequate ductility exists at sections/locations where successive hinges/yield lines form and these methods adequately model the global effects in combination with local plasticity.
- (3) The application of elastic methods of analysis for factored loads for the ultimate limit state in general, leads to safe lower bound solutions. These may be refined and made more accurate and less conservative. For suitable methods, specialist literature may be referred.
- (4) For longitudinal members effects due to temperature gradient may be neglected.
- (5) Strut-and-tie model may be used in the analysis of discontinuity regions. Struts representing compressive stress field and ties provided by reinforcement, meet at connecting nodes forming statically stable truss system. The reinforcement carries full design force of the tie over its full length and hence is required to be adequately anchored beyond the node. Adoption of model developed on the basis of stress trajectories in compression and tensile regions, established from linear elastic analysis or following direct and simple load path method, should be preferred as it will help in achieving crack control at serviceability conditions. Specialist literature may be referred for details.

7.4 Torsional Effects

7.4.1 Where static equilibrium of a structure depends on the torsional resistance of its elements, full torsional design covering ULS shall be made.

7.4.2 In general, where the torsional resistance or stiffness of members has not been taken into account in the analysis of the structure, no specific calculations for resisting torsion will be necessary. In such cases adequate control of any torsional cracking should be achieved by providing nominal reinforcement to resist torsion. However, in applying this clause it is essential that sound engineering

judgement is exercised in deciding whether torsion plays only a minor role in the behaviour of the structure; otherwise torsional stiffness should be used in the analysis.

7.5 Combined Global and Local Effects

In addition to the design of individual elements to resist loading applied directly to them, it is also necessary to consider the loading effects due to global loading where these coexist in an element.

Analysis of the structure may be accomplished either by one overall analysis or by separate analyses for global and local effects. In the latter case, the forces and moments acting on the element from global and local effects should be combined as appropriate. The design of individual elements should take into account the combined effects.

7.6 Structures and Structural Frames

7.6.1 Beams

7.6.1.1 Effective span

- (1) The effective span of a simply supported member should be taken as the smaller of:
 - (a) The distance between the centres of bearings,
 - (b) The clear distance between supports plus the effective depth.
- (2) The effective span of a member framing into supporting members should be taken as the distance between the centres of the supporting members.
- (3) The effective span of a continuous member should be taken as the distance between centres of supports.
- (4) In the case of beams framing into wide columns, the effect of column width should be included in the analysis.

7.6.1.2 Effective width of flanged beams and box beams

- (1) For analysis of section for ULS & SLS effective width shall be taken as given in **Fig. 7.1** & Eq.7.1.

The effective flange width b_{eff} for a T beam or L beam may be derived as:

$$b_{eff} = \sum b_{eff,i} + b_w \leq b \quad \text{Eq. 7.1}$$

$$\text{with } b_{eff,i} = 0.2b_i + 0.1l_o \leq 0.2l_o,$$

$$\text{and } b_{eff,i} \leq b_i \quad (\text{For the notations see Fig. 7.1})$$

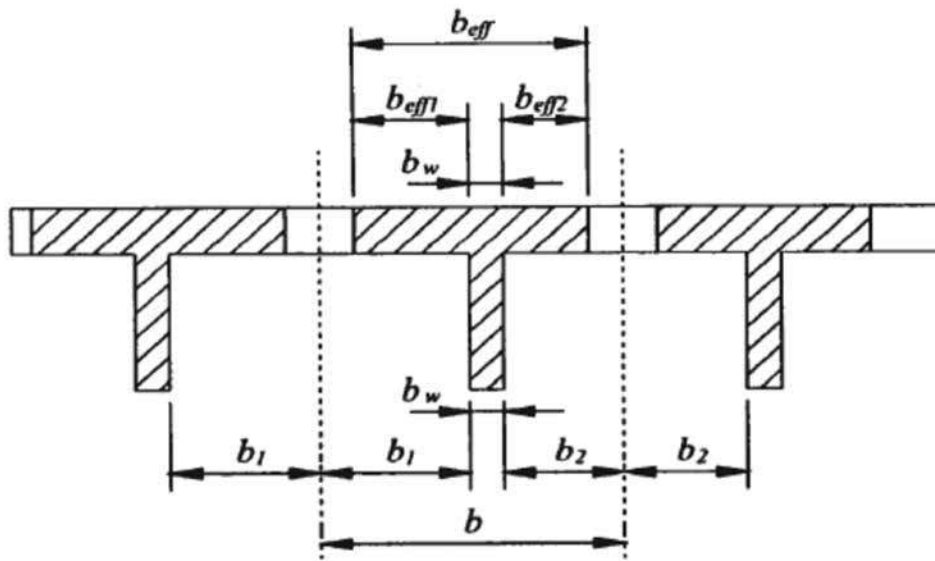

Fig. 7.1 Definition of Parameters to Determine Effective Flange Width

- (2) l_o = The distance between the points of zero moments (in the absence of rigorous calculations for continuous span it may be taken as 0.7 times effective span). The effective width may be taken as constant for the full span.
- (3) For limit state check of vibration for footbridge the actual flange width may be used.

7.6.2 Slabs

7.6.2.1 Moment and shear forces in solid slabs

Moments and shear forces in slab bridges, in the top slabs of beam-and-slab bridges, and box girder bridges may be obtained from any rational and established method of analysis. The effective spans should be in accordance with Section 7.6.1.1.

7.6.2.2 Special types of slabs

For analysis of special type of slabs such as skew slab, curved slabs, voided slabs and composite slabs, specialist literature may be referred.

7.6.3 Columns

7.6.3.1 Definitions

A reinforced concrete column is a compression member whose largest lateral crosssectional dimension is less than or equal to four times its lesser lateral dimension. A column should be considered as short if the ratio l_e/i in each plane of buckling is such that the failure takes place without involving secondary effects. In practice, the limits upto which the secondary effects can be neglected is given in Clause 11.2.

7.6.3.2 *Moments and forces in columns*

- (1) The moments, shear forces and axial forces in a column should be determined in accordance with Clauses 7.2 and 7.3, except that if the column is slender the additional moments induced by lateral deflection should be considered. The bases and/or other members connected to the ends of such columns should also be designed to resist these additional moments.
- (2) In columns with moments it is generally sufficient to consider the maximum and minimum ratios of moment/axial load in designing reinforcement areas and concrete sections.

7.6.3.3 *Buckling of columns and overall structure*

For rules regarding verification of safety against buckling, refer Section 11.0.

7.6.4 *Reinforced concrete walls*

7.6.4.1 *Definition*

A wall is a vertical load bearing concrete member whose larger lateral dimension is more than four times its lesser lateral dimension. A wall may be considered as short where the ratio of its effective length (height) to its thickness does not exceed 12. It should otherwise be considered as slender. Retaining walls, wing walls, abutments and other similar wall-like elements where ultimate axial load is less than $0.1 f_{cd} A_c$ may be designed as bending elements, neglecting axial load.

7.6.4.2 *Forces and moments in reinforced concrete walls*

Forces and moments should be calculated in accordance with Clauses 7.2 and/or 7.3 except that if the wall is slender, the moments induced by deflection should also be considered. The distribution of axial and horizontal forces along a wall from the loads on the superstructure, should be determined by the type and location of the supports. For walls integral with deck, the moments/forces should be determined by elastic analysis.

The design moment per unit length in the direction at right angles to a wall should be not less than $0.05 n_w h$, where n_w is the ultimate axial load per unit length, $0.05h$ is the nominal minimum eccentricity and h is the thickness of the wall. Moment in the plane of a wall can be calculated from statical equilibrium required for the most severe positioning of the relevant loads.

Where the concentrated load is acting on a wall, dispersal of loads within the length and height of the wall shall be considered.

It will generally be sufficient to consider the maximum and minimum ratios of moment to axial load in designing reinforcement areas and concrete sections.

7.7 **Composite Concrete Construction**

7.7.1 *General*

- (1) These recommendations apply to flexural members consisting of precast concrete units acting in conjunction with cast-in-situ concrete, where provision has been made for the

transfer of horizontal shear at the contact surface. The precast units may be of either reinforced or prestressed concrete.

- (2) Differential shrinkage and creep of the component concrete members requires consideration in analysing composite members for the serviceability limit states. Differential shrinkage and creep need not be considered for the ultimate limit state.
- (3) In general, the analysis and design of composite concrete structures and their component members should be in accordance with the principle defined earlier except that effects of differential shrinkage and creep should be treated as a primary action. Particular attention should be given in the design of the component parts and the composite section to take into account the effect on stresses and deflections arising out of the method of construction (e.g. whether props are used or not used).
- (4) A check for adequacy of components/whole section should be made for each stage of construction. The relative stiffness of members should be based on the concrete or gross transformed section properties as described in Clause 7.2. If the concrete strengths of the two components of the composite member differ by more than $10N/mm^2$, allowance for the difference in moduli of elasticity should be made in assessing stiffness and stresses.
- (5) When at least one of the components is a prestressed member, the combined effect of shrinkage and creep movements of the prestressed member(s) with respect to other member(s) create time dependent variation of stresses, which may be more severe at intermediate stages leading to tensile cracking. The time dependent properties of shrinkage and creep given in Section 6 should be used in this evaluation.
- (6) When only the shrinkage effects are involved, it is sufficient to analyse for the maximum value of differential shrinkage.

7.7.2 Continuity of spans in composite construction

When continuity is obtained in composite construction by changing the statical system, consideration should be given to the secondary effects of differential shrinkage and creep on the moments in continuous beams and on the reactions at the supports.

7.7.2.1 Effect of differential shrinkage

The hogging restraint moment, M_{cs} at an internal support of a continuous composite beam and slab section due to differential shrinkage should be taken as:

$$M_{cs} = (\varepsilon_{diff}) (E_{cf}) A_{cf} (\delta_{cent}) \alpha \quad \text{Eq. 7.2}$$

Where

- ε_{diff} is the differential shrinkage strain;
- E_{cf} is the modulus of elasticity of the flange concrete;
- A_{cf} is the area of the effective concrete flange;
- δ_{cent} is the distance of the centroid of the concrete flange from the centroid of the composite section;

α is a reduction coefficient to allow for creep

$$\alpha = \frac{1 - e^{(-)\phi}}{\phi}, \text{ where } \phi \text{ is the creep co-efficient} \quad \text{Eq. 7.3}$$

7.7.2.2 Creep redistribution due to dead load and prestress in the precast Unit

When a concrete structure's statical system is changed during construction, creep of the concrete will modify the as-built bending moments (and shear forces) towards the 'instantaneous' moments (and shear) distributions. The additional moment due to creep redistribution, M_{cr} should be taken as:

$$M_{cr} = (M_{inst} - M_{as-built})\alpha_i \quad \text{Eq. 7.4}$$

where,

M_{inst} is the bending moment, which would have been set up in case the composite section as a continuous structure had been subjected to the dead load and prestress component, which was actually applied in the precast unit.

$M_{as-built}$ is the actual bending moment set up in the structure as constructed.

Note: This will depend upon the time gap when composite action is established after casting pre-cast portion and whether in-situ concrete is cast while pre-cast beam is supported on props and decentred after achieving composite section or cast on the beam which takes full self-weight and weight of shuttering without help of composite action.

Values of reduction coefficient α_i are calculated from expressions below using ϕ value taken from **Table 6.9**.

$$\alpha_i = [1 - e^{-\phi}] \quad \text{Eq. 7.5}$$

Where, e is the base of Napierian Logarithms

7.8 Structural Effects of Time-Dependent Properties of Concrete

- (1) The inelastic strains due to creep and shrinkage of concrete may cause appreciable changes in the long-term state of deformation stresses in the structure and structural elements.
- (2) The performance with respect to serviceability is of primary concern.
- (3) In slender or thin sections where second order deformations are important, the increase of deflections due to creep reduces the longterm safety margin with respect to buckling instability and may lead to creep buckling. In such cases it should be treated as a primary effect.
- (4) Shrinkage and creep act in a complex interdependent way. The creep of concrete reduces internal stresses induced by shrinkage. Where great accuracy is not required, this effect can be directly evaluated by using reduced value of modulus of elasticity of concrete [approx. $E_{cm} / (1 + \phi)$, refer Section 6] which corresponds to the stresses caused by the imposed strains.
- (5) The restrained thermal stresses arising from seasonal variation in temperatures are similarly reduced by creep and can be directly evaluated by reduced E value of 0.5 times E_{cm} .

- (6) For purpose of analysis of creep and shrinkage treated as acting independently, time-dependent properties of concrete and relaxation of steel given in Section 6 can be used.

7.9 Prestressed Members and Structures

Prestressing force applied by pre-tensioned steel or by post-tensioned steel and transferred to the structure through bond between steel and concrete or through mechanical anchorages, is covered in this Section.

7.9.1 General

- (1) Prestressing is considered as an action and its effect should be included in the forces/ moments and applied to the structure.
- (2) Prestressing force is time-dependent. Its magnitude also varies from the intended value due to technological reasons. Both the effects should be considered in selection of design prestressing force.
- (3) The contribution of prestressing tendons to the resistance developed by the member shall be limited to the additional forces mobilized by their further deformation, consistent with the ultimate deformation of the member.

7.9.2 Maximum prestressing force

- (1) The maximum force applied to tendon at active end during tensioning, shall not exceed 90 percent of 0.1 percent proof load (or proof-stress).
- (2) In exceptional conditions temporary overstressing during stressing operation is permitted up to 95 percent of 0.1 percent of proof load(or proof stress), provided that the accuracy of measurement is ensured to be within ± 5 percent.
- (3) Maximum prestressing force P_0 applied to structure immediately after transfer (i.e. after losses due to elastic shortening and anchorage slip) shall not be greater than 75 percent of f_{pk} or 0.85 of 0.1 percent proof load whichever is less (Refer **Fig. 6.3**).

7.9.3 Loss of prestress

7.9.3.1 Immediate losses in pre-tensioning

The following losses occurring during pre-tensioning shall be considered:

- (1) During the stressing process:
Loss due to friction at the bends (in the case of curved wires and strands) and losses due to wedge draw-in of the anchorage devices.
- (2) Before the transfer of prestress to concrete:
Loss due to relaxation of the pre-tensioning tendons during the period between the tensioning of tendons and release of the same for transfer of prestress.

Note: In case of steam curing, losses due to shrinkage and relaxation are modified and should be assessed accordingly. **Annexure 2** and/or specialist literature may be referred. Direct thermal effect on prestressing steel should also be considered.

- (3) At the transfer of prestress to concrete;

- (a) Loss due to elastic deformation of concrete.
- (b) Loss due to draw-in of tendon at two ends of concrete member, taking into account favourable/unfavourable bond condition.

7.9.3.2 Immediate losses of prestress in post-tensioning

(1) Losses due to the elastic deformation of concrete

Loss in tendon force corresponding to elastic shortening of concrete at the level of tendon shall be taken into account. The order in which the tendons are stressed shall be considered for calculation of loss.

(2) Losses due to friction and wobble

- (a) The losses due to friction and wobble ΔP_μ are calculated by Eq.7.6 where P_0 is the initial prestressing force which reduces by $\Delta P_\mu(x)$, at distance x

$$\Delta P_\mu(x) = P_0 (1 - e^{-(\mu\theta + kx)}) \quad \text{Eq. 7.6}$$

where

θ Measured in radians is the sum of the angular displacements over a distance x (irrespective of direction or sign)

μ is the coefficient of friction between the tendon and its duct.

k is a coefficient for wobble effect (representing angular displacement per unit length of duct multiplied by μ).

x is the distance along the tendon from the point where the prestressing force is equal to P_0 .

P_0 force at $x=0$. It is maximum force at active end during tensioning.

- (a) The value of μ depends on the surface characteristics of the tendons and the duct, on configuration of the tendon profile, and on the presence of rust, if any. The value k for wobble (μ times unintentioned angular displacement per unit length) depends on the quality of workmanship, distance between tendon supports, type of duct or sheath and degree of vibration while compacting the concrete.
- (b) In the absence of more exact data values for μ and k given in **Table 7.1** may be adopted for design. The values of μ and k used in design shall be indicated on the drawings for guidance in selection of the material and the methods that will produce results approaching the assumed values.
- (c) For external tendons, consisting of parallel wires or strands, the loss of prestress due to wobble effect between the deviators may be ignored.
- (d) During construction the value of effective prestress obtained on basis of values assumed in design should be verified by stressing a few typical tendons. For this purpose, two jacks shall be used between the activities - one for pulling the tendon (active jack) and other as passive jack. The force in tendon should be measured at both ends by means of pressure gauges or load cells. The difference between forces at two ends will indicate the actual loss due to friction and wobble. If the loss is more than ± 5 percent of that adopted in design, it should be referred to designer for corrective action.

- (3) Losses at Anchorage
- Losses due to wedge draw-in of the anchorage devices, during anchoring and due to the deformation of the anchorage itself, should be taken into account.
 - Values of (a) as normally given by the manufacturer, shall be used in the design. If the manufacturer is not finalised at the time of design, values based on experience shall be used and stated on the drawing or on stressing schedule to enable proper adjustments to be made at site.

Table 7.1 Coefficients of Friction (μ) & Wobble Effect (k) of Post Tensioned Tendons and External Unbonded Tendons

Type of high Tensile Steel	Type of Duct or Sheath	Values recommended to be used in design	
		k per metre	μ
Wire cables	Bright metal steel	0.0091	0.25
	Galvanised steel	0.0046	0.20
	Lead coated steel	0.0046	0.18
	Unlined duct in concrete	0.0046	0.45
Uncoated Stress Relieved Strands	Bright Metal steel	0.0046	0.25
	Galvanised steel	0.0030	0.20
	Lead coated	0.0030	0.18
	Unlined duct in concrete	0.0046	0.50
	Corrugated HDPE	0.0020	0.17

7.9.3.3 Long term losses in pre-tension and post-tension

Long term losses are due to creep and shrinkage of concrete and relaxation of steel. These should be taken into account including their time-dependency.

7.9.4 Consideration of prestress in analysis

- For linear analysis both the primary and secondary effects of prestressing shall be applied.
- Full bond between steel and concrete may be assumed after grouting of bonded tendons. However, before grouting, the tendons shall be considered as unbonded.
- External tendons may be assumed to be straight between deviators.

7.9.5 Partial factors for prestressing force

- Prestress in most situations, is intended to be favourable. However, under some load combinations the effect may become unfavourable.
- In case of bonded tendons, for ultimate limit state of strength, the design value of prestressing force shall be based on the mean value acting at that time, with partial factor $\gamma_p=1$.

- (3) In case of unbonded tendons and external tendons, the stress increase in ultimate limit state of strength may be calculated taking into account the overall deformation of the member. If no such calculations are made, the increase in stress in prestressing tendon shall be taken as nil, and partial factor $\gamma_p=1$.
- (4) Where external/unbonded tendons are used for achieving stability and where decrease of force or increase of force becomes unfavourable for stability, partial factors of 0.8 and 1.25 shall be used to decrease or increase the force, as required.

Note: These factors account for the possible adverse variation in prestressing force. This shall be over and above the overall safety factors against overturning and sliding required for global stability checks.

- (5) In verification of local effects $\gamma_{p,unfavourable}=1.3$ shall be used.
- (6) In serviceability limit state, two characteristic values of prestressing force shall be used.

$$P_{k.sup} = \gamma_{sup} P_m(t)(x) \quad \text{Eq. 7.7}$$

$$P_{k.inf} = \gamma_{inf} P_m(t)(x) \quad \text{Eq. 7.8}$$

Where

$P_m(t)(x)$ is effective prestressing force at point 'x' at time 't' and $P_{k.sup}$ and $P_{k.inf}$ are corresponding superior and inferior characteristic values. The values of γ_{sup} and γ_{inf} shall be as follows:

- for pre-tensioning or unbonded tendons $\gamma_{sup}=1.05$ and $\gamma_{inf}=0.95$.
- for post-tensioning with bonded tendons $\gamma_{sup}=1.10$ and $\gamma_{inf}=0.9$.

7.9.6 Part prestressing of tendon

The requirement of minimum concrete strength behind the anchorages of post tensioned system, at the time of stressing, for full jacking force, designated as $f_{c.str}$ shall be specified by the designer taking into account special requirements of the structure, if any, and the recommendations of the manufacturer of prestressing system.

If any individual tendon is stressed in stages before the specified strength $f_{c.str}$ of concrete is achieved, the relation between the stage stressing and specified minimum strength shall be as follows:

- For 100% jacking force, minimum concrete strength is $f_{c.str}$.
- For 30% of jacking force minimum concrete strength = $0.5 f_{c.str}$
- Between 30% and 100% of jacking force minimum concrete strength shall be arrived at by linear interpolation between $0.5 f_{c.str}$ and $f_{c.str}$.

7.10 Design and Detailing for Curved Tendons in Thin Sections

7.10.1 Radial pressure from curved tendons

The curved tendons exert radial pressure on concrete. This introduces local compression on inner side of the curvature and tension on outer side of curvature in the plane of the tendon. When this pressure acts on thick sections with large cover to ducts or in plane of the member, the normal reinforcement provided for shear or surface reinforcement is adequate to control any cracking in this region.

For tendons provided in thin curved sections (like webs curved in plan or curved slabs of box sections) pressure acting outwards from the plane of the member causes local out-of plane punching shear as

well as overall bending and shear in the curved members. The following additional checks shall be carried out in such situations.

7.10.2 Shear checks

Shear should be checked in the immediate vicinity of the ducts in accordance with the empirical equations shown in **Fig. 7.2**, which are based on experimental results.

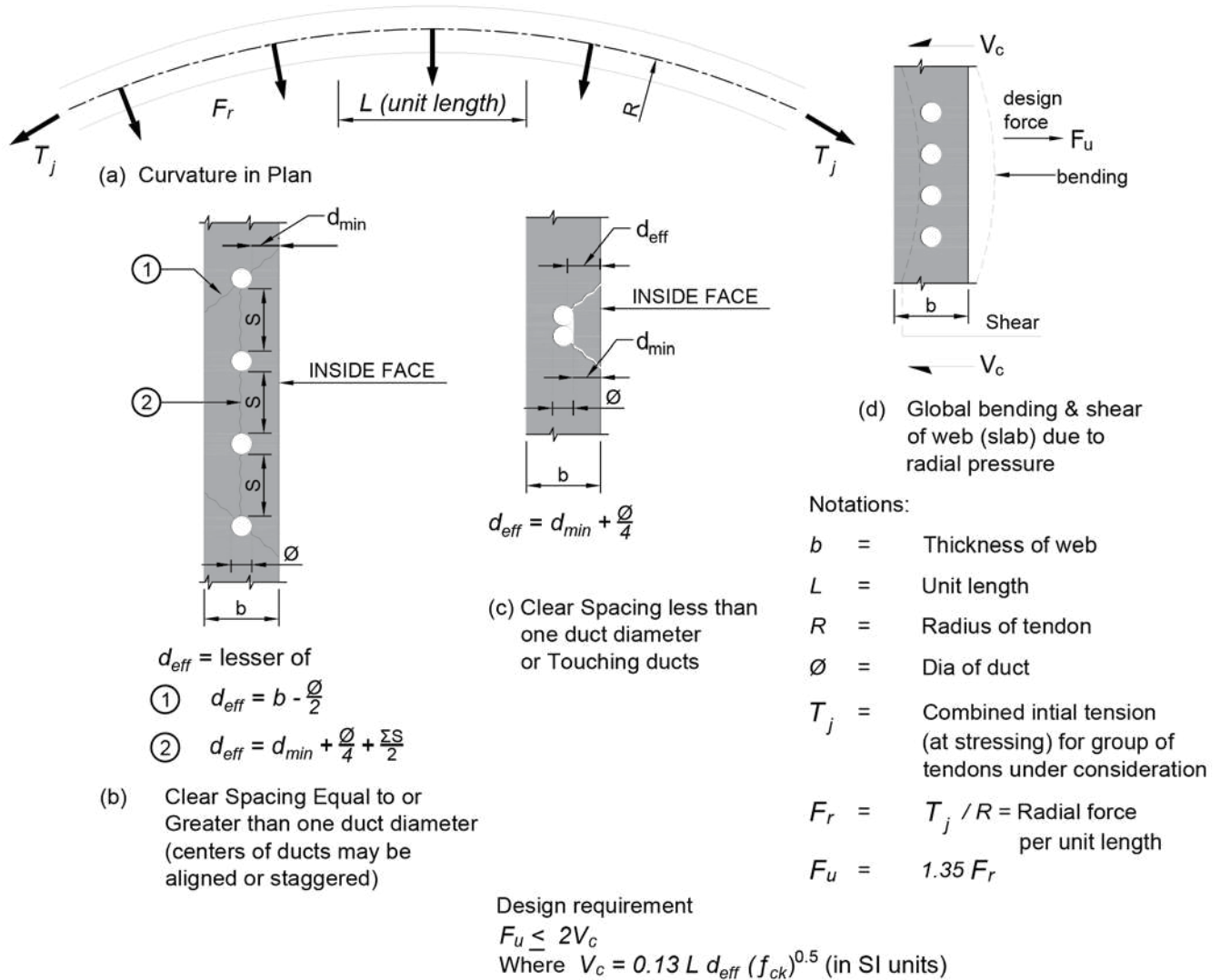

Fig. 7.2 Radial Thrust of Tendons Causing Local Punching and Global Bending and Shear in Webs (Slab)

7.10.3 Radial reinforcement

The local radial tensions set up in concrete behind radial thrust of a group of ducts lying in one plane, introduce de-laminating forces tending to separate concrete on two sides of the plane of the duct. These tensions should be resisted by reinforcement forming full loops or 180° hooks (**Fig. 15.2(e)** with 180° bend) placed in the concrete section connecting concrete on two sides of plane of ducts. As a simplification, full radial thrust F_r (**Fig. 7.2**) can be resisted by HYSD reinforcement steel limiting permissible tensile stress to 230 MPa.

7.11 Special Load Transferring Devices

7.11.1 *General*

Devices like bearings of various types, dislodgement preventing stoppers and shock transmission units are used to transmit loads between parts of bridge elements. The global analysis of the structure should include the overall behaviour of these elements in terms of their load/deformation characteristics in a simplified way, by defining the released and restrained movements of the structure to which they are connected. However, the design of these elements themselves shall be based on the details of internal load transferring mechanism and materials used in their fabrication.

7.11.2 *Grade effect and positioning of bearings*

For bridges built in grade or cross-fall, the bearings shall normally be set level by varying the thickness of the plate situated between the upper face of the bearing and lower face of the beam or by any other suitable arrangement. However, where the bearings are required to be set parallel to the inclined grade or cross-fall of the superstructure, an allowance shall be made for the longitudinal and transverse components of the vertical loads on the bearings.

SECTION 8

ULTIMATE LIMIT STATE OF LINEAR ELEMENTS FOR BENDING AND AXIAL FORCES

8.1 Scope

- (1) This Section covers structural members which can be idealised as linear members having the following characteristics: (a) one of the dimension (length or height) is sufficiently large as compared to other two dimensions of its cross-section (breadth, width, thickness), (b) the cross-sections which were plane before loading remain approximately plane after loading and loading is such that the distortion of the section by shear and torsional strains is not large enough to vitiate this assumption, (c) the regions of geometric discontinuity and heavy transverse loads where the assumption in (b) does not hold good locally, form a small part of the total length.
- (2) Generally, members having length larger than 4 times the largest linear dimension of cross-section, can be considered to belong to this class. Under certain conditions of loading members having length between 1 to 4 times the cross-sectional dimensions will qualify for being treated as linear members (e.g. short columns without bending created by transverse shear).
- (3) Ultimate load carrying capacity of predominantly axially loaded members is adversely affected by instability (buckling) for long members by effect of second-order deformations caused by initial geometric imperfections, unintentional and small eccentricity of external loads or effect of lateral deflection due to transverse loading or end fixity conditions (moments). Additional checks for such effects and design of slender members in general are included in Section 11.
- (4) Simplified methods for bi-axial bending are covered.
- (5) Simplified methods for small magnitudes of axial forces acting together with bending moments are covered.

8.2 Strain and Stress Distribution at Ultimate Limit State

8.2.1 *Limitations on strain and stresses*

- (1) In analysing a cross-section to determine its ultimate resistance, the assumptions given below shall be used:
 - (a) Plane sections remain plane.
 - (b) The strain in bonded reinforcement and in bonded prestressing steel beyond the initial pre-tension before bonding, whether in tension or compression, is the same as that in the surrounding concrete.
 - (c) The tensile strength of the concrete is ignored.
 - (d) The stresses in the concrete in compression are derived from the design stress-strain diagram in **Fig. 6.5**, which is a parabolic-rectangular diagram. For other shapes of stress-strain diagram, refer **Annexure A-2**.

- (e) The stresses in the reinforcement steel are derived from the design curves in **Fig. 6.2**, and the stresses for prestressing steel are derived from **Fig. 6.3** or **Fig. 6.4** as appropriate, after dividing stresses by partial factor for materials as shown.
 - (f) When upward sloping branch of stress-strain curve beyond the linear elastic portion is used, the tensile stresses in reinforcing and prestressing steel are limited to those corresponding to strain of $0.9 \epsilon_{uk}$. Where idealised plastic branch is used for this part of the curve, it is not necessary to check strain limit.
 - (g) The initial pre-strain introduced in prestressing tendons is taken into account when assessing the stresses in the tendons at the ultimate limit state.
 - (h) For cross-sections subject to pure longitudinal compression, the compressive strain in the concrete is limited to ϵ_{c2} .
 - (i) For cross-sections subject to axial compressive force and bending and where neutral axis lies outside the section, the strain at most compressed face is restricted to ϵ_{cu2} . The strain diagram is defined by assuming that the compressive strain ϵ_{c2} is at a level $(1-\epsilon_{c2}/\epsilon_{cu2})$ of the height of the section from the most compressed face.
 - (j) For cross-sections subjected axial compressive force and bending moment where the cross-section is not fully in compression and neutral axis lies within the section, the strain at the most compressed face is taken as ϵ_{cu2} , for use with parabolic rectangular stress-strain diagram of concrete portion in compression.
 - (k) Possible range of strain distributions is shown in **Fig. 8.1**.
- (2) For values of deformation characteristics of concrete such as, ϵ_{c2} , ϵ_{cu2} refer **Table 6.5**.
- (3) In parts of cross-section which are subject to approximately compressive loading ($e/h < 0.1$), such as compression flange of box girder, the mean compressive strain in that part of section should be limited to ϵ_{c2} .

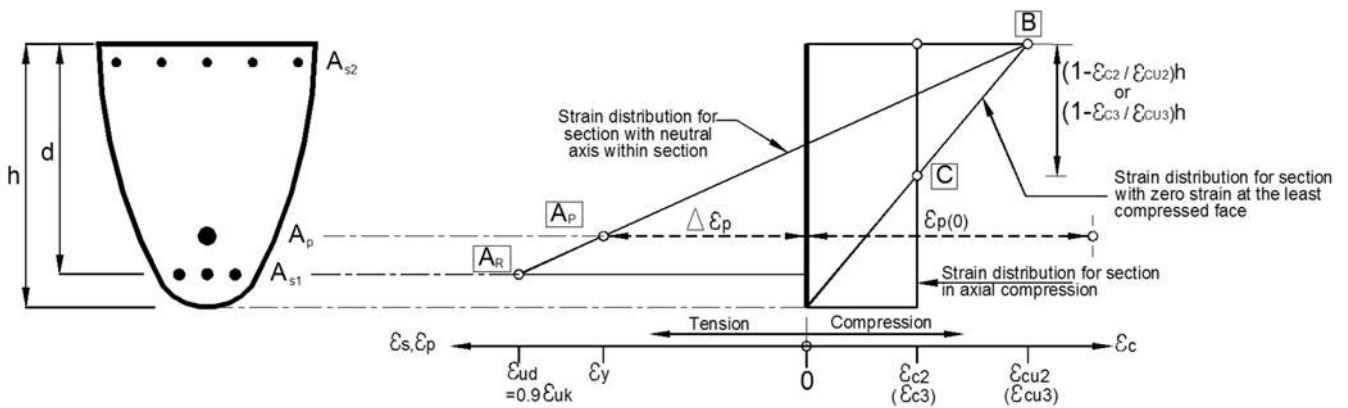

- A_P – Prestressing steel tensile strain limit
- A_R – Reinforcing steel tensile strain limit
- B – Concrete bending plus axial compression strain limit
- C – Pure compression strain limit

Fig. 8.1 Possible Strain Distributions in the Ultimate Limit State

- (4) If changes in the position of the reinforcement such as at a lap can lead to a localised reduction in the effective depth, the most unfavourable value should be used in the cross-section analysis.

- (5) For prestressed members with permanently unbonded internal or externally prestressed tendons, it is generally necessary to take the deformation of the whole member into account. Refer Clause 7.9 for the suitable method of analysis.
- (6) In the analysis of a cross-section which has to resist bending and only a small longitudinal force, the effect of the design ultimate longitudinal compressive force may be ignored, if it does not exceed $0.08 f_{ck}$ times the cross-sectional area. The tensile force due to bending and the axial tensile force on the member shall be entirely carried by reinforcement.
- (7) The bending resistance calculated on the basis of above assumptions, is strictly valid for bending in the planes of principal axes. For bending at any other axis, the approximate solutions given in Clause 8.3.2 may be used.
- (8) Based on the principles and assumptions given in this Section, exact solutions for cross-sections of variable width/depth may be evolved. Local large openings in cross-section should be accounted for (e.g. those caused by transversely or obliquely running cable ducts).

8.2.2 Further explanation of possible domains of strain diagrams

The adoption of the assumptions in Clause 8.2.1 leads to the range of possible strain diagrams at ultimate limit states subjected to different combinations of moment and axial tensile/compressive force, as shown in Fig. 8.2.

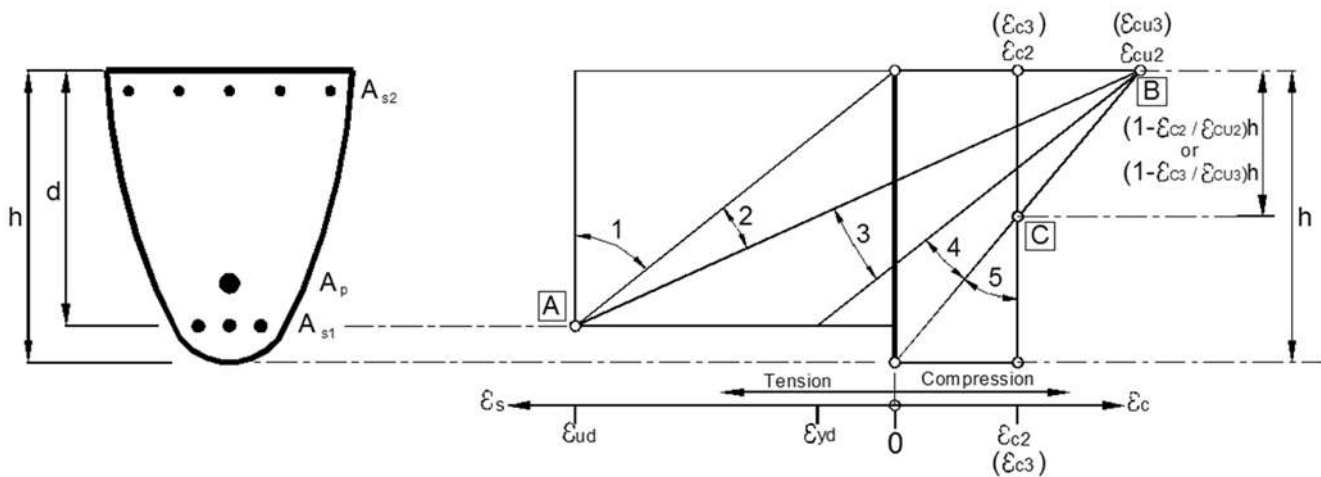

Fig. 8.2 Domains of Strain Distributions

Angular Deviation '1' to '5' denotes following:

- 1 Pivot point is 'A', where tensile strain $\epsilon_u = \epsilon_{ud}$ in reinforcement. Section is fully in axial tension with some bending. Neutral axis outside the section. Compressive strain in concrete, $\epsilon_c \leq 0$ (Negative). Failure occurs due to yielding of steel.
- 2 Pivot point is 'A', where tensile strain $\epsilon_u = \epsilon_{ud}$ in reinforcement. Section is in combined axial and bending. Neutral axis within the section. Compressive strain in concrete, $0 \leq \epsilon_c \leq \epsilon_{cu2}$. Failure occurs due to yielding of steel.
- 3 Pivot point is 'B', where compressive strain $\epsilon_c = \epsilon_{cu2}$ in concrete. Section is in combined axial and bending. Neutral axis within the section. Strain in reinforcement, $\epsilon_{yd} \leq \epsilon_s \leq \epsilon_{ud}$. The failure of the section occurs by an excess of plastic strain in concrete.
- 4 Pivot point is 'B', where compressive strain $\epsilon_c = \epsilon_{cu2}$ in concrete. Section is in combined axial and bending. Neutral axis within the section. Strain in reinforcement, $\epsilon_s \leq \epsilon_{yd}$. The failure of the section occurs by an excess of plastic strain in concrete.

- 5 Pivot point is 'C', where compressive strain $\varepsilon_c = \varepsilon_{c2}$ in concrete. Section is in axial compression with some bending. Neutral axis outside the section. The failure of the section occurs by an excess of average strain in concrete.

Zone-1: Tensile load with/without eccentricity

The entire section is in tension, the neutral axis lies outside the section and its location depends on the eccentricity of the tensile force. Reinforcing/prestressing steel at least on one side yields (with strains limited as per either idealised or simplified diagrams) which decide the ultimate tensile capacity.

Zone-2: Compressive load with eccentricity, having neutral axis within section, and ultimate strength governed by tensile steel

The maximum strain in the concrete is less than the limiting value of ε_{cu2} thus the strength of the concrete is not exhausted. The tensile strain at steel is at the upper design limit of ε_{ud} .

Zone-3 : Compressive load with eccentricity, having neutral axis within section, and steel beyond yield, ultimate strength governed by concrete

The concrete compression strain at the upper fibre is at upper design limit ε_{cu2} . The steel strain lies between ε_{yd} and ε_{ud} .

Zone-4 : Compressive load with eccentricity, with ultimate strength governed by concrete and steel strain is below yield strain.

This is typically the cause of steel strength not fully exploited giving over-reinforced non-ductile failure.

The boundary between Zone-3 and Zone-4 is called the balanced condition, where the maximum concrete strain (ε_{cu2}) and reinforcement strain at yield (ε_{yd}) are present simultaneously.

Zone-5: Compressive load with eccentricity, having neutral axis outside the section (i.e. full section in compression)

The entire section (with exception of possibly existing prestressing steel) is in compression. All strain profiles pass through point C. The maximum compressive strain of concrete at C is between ε_{cu2} and 0. C lies where the line BO (which defines the boundary between sections partially in tension and sections in compression) intersects the vertical line characterized by $\varepsilon_{c2} = \text{constant}$. The distance of this point from the outermost compressive fibre is taken as equal to $\left(1 - \frac{\varepsilon_{c2}}{\varepsilon_{cu2}}\right)h$ of the total depth of the section.

8.3 Biaxial Bending

8.3.1 General solution

The analysis of members of generalised cross-section having irregular shape is not normally required in bridge design. Methods are available in specialist literature for members having at least two orthogonal axes of symmetry, where loads can be split in components acting in plane of bending of each of the axes and the shear centre coinciding with the C.G of the section. The restrictions on the ultimate strains on concrete and steel specified in Clause 8.2.1 shall be observed.

8.3.2 Simplified method for bi-axial bending and axial force

- (1) The simplified method described below may be used for bi-axial bending. Special care should be taken to identify the section along the member with the critical combination of moments. Where more accurate analysis is required, specialist literature may be referred.
- (2) Separate design in each principal direction, disregarding bi-axial bending, is done as a first step. Imperfections need to be taken into account only in the direction where they will have the most unfavourable effect.
- (3) No further check is necessary if the slenderness ratios satisfy the following two conditions expressed by Eq.8.1 and if the relative eccentricities e_z / b and e_y / h satisfy one of the following conditions expressed by Eq.8.2 (Refer **Fig. 8.3** for notations).

$$\lambda_y / \lambda_z \leq 2 \text{ and } \lambda_z / \lambda_y \leq 2 \quad \text{Eq. 8.1}$$

and

$$\frac{e_y / h_{eq}}{e_z / b_{eq}} \leq 0.2 \text{ or } \frac{e_z / b_{eq}}{e_y / h_{eq}} \leq 0.2 \quad \text{Eq. 8.2}$$

Where

z, y Two principal axes of the cross-section.

b, h Width and depth of section

$b_{eq} = i_y \sqrt{12}$ and $h_{eq} = i_z \sqrt{12}$ for arbitrary section, and equal to width/depth for rectangular sections as applicable w.r.t. plane of bending.

λ_y, λ_z are the slenderness ratios i_o / i with respect to y-axis and z-axes respectively.

i_y, i_z Radius of gyration with respect to y-axis and z-axis respectively.

e_z, e_y Eccentricity of N_{Ed} with reference to z and y axis, as shown in **Fig. 8.3**.

N_{Ed} Design value of resultant axial load in the respective load combinations.

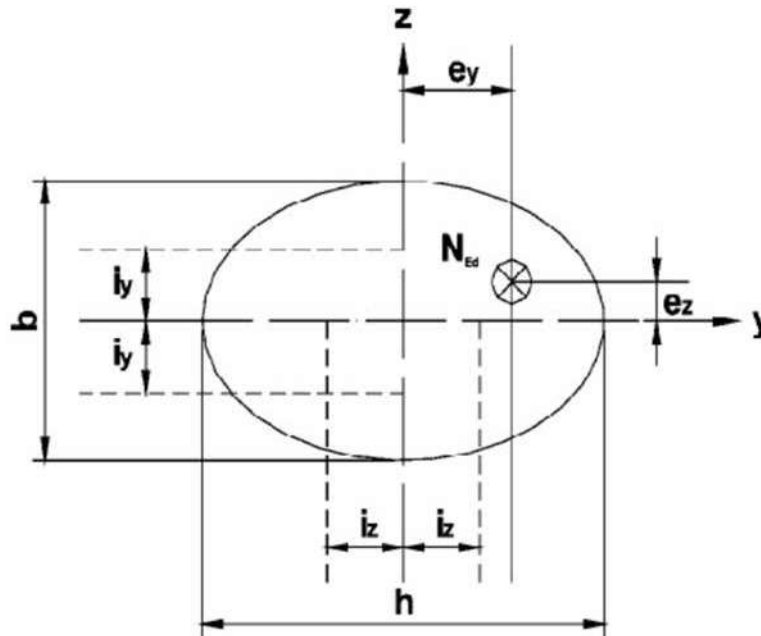

Fig. 8.3 Definition of Eccentricities e_y and e_z of Applied Axial Force Resultant N_{ED}

- (4) If the condition of Eq.8.1 and Eq.8.2 are not fulfilled, bi-axial bending should be taken into account including the second order effects in each direction (unless they may be ignored according to Clause 11.1.5. In the absence of an accurate cross-section design for biaxial bending, the following simplified criterion may be used.

$$\left(\frac{M_{Edx}}{M_{Rdx}}\right)^\alpha + \left(\frac{M_{Edy}}{M_{Rdy}}\right)^\alpha \leq 1$$

Eq. 8.3

Where

M_{Edx} , M_{Edy} Design moment around the respective axis, including nominal 2nd order moments.

M_{Rdx} , M_{Rdy} Moment resistance in the respective direction;

Exponent as follows:

- for circular and elliptical cross-sections: $\alpha = 2$

- for rectangular cross-sections:

N_{Ed} / N_{Rd}	0.1	0.7	1.0
$\alpha =$	1.0	1.5	2.0

With linear interpolation for intermediate values.

$N_{Ed} =$ design value of axial force.

$N_{Rd} = A_c f_{cd} + A_s f_{yd}$ design axial resistance of section.

where

A_c is the gross area of the concrete section.

A_s is the area of longitudinal reinforcement.

SECTION 9

ULTIMATE LIMIT STATE OF TWO AND THREE DIMENSIONAL ELEMENTS FOR OUT OF PLANE AND IN PLANE LOADING EFFECTS

9.1 Scope

This Section deals with plate and shell type elements and sub-elements where out of plane loading effects as well as in plane loading effects are present. The permissible simplifications for separating in-plane and out-of-plane effects and designing for the same are given. A method of providing reinforcement for in-plane effects is indicated.

For use of three dimensional elements as bridge elements (e.g. shell elements as in case of fish-belly superstructure) apart from designing for sectional strength, overall and local buckling checks may be required. Specialist literature may be referred for the same.

9.2 One-Way and Two-Way Slabs and Walls

For predominantly transverse loads acting perpendicular to the plane of the slab, where primary overall in plane tensile or compressive stress fields are absent, the slabs/walls can be designed using conventional plate bending analysis and providing ultimate strength in bending and shear in one and/or two orthogonal directions as required by such analysis. Bridge deck slabs, retaining walls resisting lateral earth pressures etc., are the typical examples.

Any rational method of analysis which does not permit more than 15 percent redistribution of peak bending moments over supports can be used. The ultimate strength methods based on local yielding (e.g. yield line method) are not permitted. However, for calculating resistance to accidental impact loads (e.g. vehicular or barge impacts), use of such methods is permitted for which specialist literature may be referred.

9.3 Sub-Elements of Box Structures

- (1) Where box type structure resists the overall longitudinal bending, shear and torsional effects, significant in-plane longitudinal stresses are present in its sub-elements, which coexist with the local out-of-plane loading, e.g. effects due to self weight, live loads, intermediate prestressing anchorages etc.
- (2) Such elements can be designed primarily for in-plane effects arising from overall bending, shear and torsion in longitudinal direction. In transverse direction they are designed for out-of-plane loading effects.
- (3) If effects of out-of-plane loading are present in the same direction as of the overall in-plane tensions/compressions, these elements should be locally checked for combined effect of in-plane forces, and out of plane bending moments and shears.

9.4 General Solution for Two-Way Slabs, Walls and Shell Elements

For plate type elements having complex geometry and edge conditions and having in-plane as well as out-of-plane (transverse) effects due to loading, the resultant stress fields may be obtained by use

of suitable finite elements in the FEM analysis. The analysis yields resultant stresses which represent combined effects of in-plane membrane stresses and local bending effects. These stress resultants can be directly used to design tensile reinforcement and for verifying safety in compression. A general method of design using sandwich model given in informative **Annexure B-1** may be referred. Alternatively, the stresses can be converted to equivalent axial forces and bending effects in orthogonal directions and used for designing the sections following conventional methods.

9.4.1 Simplified design for tensile reinforcement for orthogonal in-plane effects

The following simplified method may be used for proportioning of tensile reinforcement based on the in-plane stresses $\sigma_{Edx} > \sigma_{Edy}$ and τ_{Edxy} .

- (1) Compressive stresses should be taken as positive, with $\sigma_{Edx} > \sigma_{Edy}$, and the direction of reinforcement should coincide with the x and y axes.
- (2) The tensile strengths f'_{tdx} and f'_{tdy} provided by reinforcement should be determined from:

$$f'_{tdx} = \rho_x f_{yd} \text{ and } f'_{tdy} = \rho_y f_{yd} \quad \text{Eq. 9.1}$$

Where ρ_x and ρ_y are the geometric reinforcement ratios, along the x and y axes respectively.

- (3) In locations where σ_{Edx} and σ_{Edy} are both compressive and $\sigma_{Edx} \cdot \sigma_{Edy} > \tau_{Edxy}^2$ design reinforcement is not required. However, the maximum compressive stress should not exceed f_{cd} .
- (4) In locations where σ_{Edy} is tensile or $\sigma_{Edx} \cdot \sigma_{Edy} \leq \tau_{Edxy}^2$ reinforcement is required.
- (5) The optimum reinforcement, indicated by superscript (') and placed in directions of concerned principal stresses are determined by :

$$\text{For } \sigma_{Edx} \leq |\tau_{Edxy}|$$

$$f'_{tdx} = |\tau_{Edxy}| - \sigma_{Edx} \quad \text{Eq. 9.2}$$

$$f'_{tdy} = |\tau_{Edxy}| - \sigma_{Edy} \quad \text{Eq. 9.3}$$

$$\sigma_{cd} = 2|\tau_{Edy}| \quad \text{Eq. 9.4}$$

$$\text{For } \sigma_{Edx} > |\tau_{Edxy}|$$

$$f'_{tdx} = 0 \quad \text{Eq. 9.5}$$

$$f'_{tdy} = \frac{\tau_{Edxy}^2}{\sigma_{Edx}} - \sigma_{Edy} \quad \text{Eq. 9.6}$$

$$\sigma_{cd} = \sigma_{Edx} \left(1 + \left(\frac{\tau_{Edxy}}{\sigma_{Edx}} \right)^2 \right) \quad \text{Eq. 9.7}$$

The concrete stress, σ_{cd} , should not exceed $v \cdot f_{cd}$. The minimum reinforcement is obtained if the direction of reinforcement is identical to the direction of principal stresses, where value of v is obtained from Eq. 10.6.

Alternatively, for the general case the necessary reinforcement and the concrete stress can be determined by:

$$f_{idx} = \left\{ |\tau_{Edxy}| \cot \theta \right\} - \sigma_{Edx} \quad \text{Eq. 9.8}$$

$$f_{idy} = \left\{ |\tau_{Edxy}| / \cot \theta \right\} - \sigma_{Edx} \quad \text{Eq. 9.9}$$

$$\sigma_{cd} = |\tau_{Edxy}| \left(\cot \theta + \frac{1}{\cot \theta} \right) \quad \text{Eq. 9.10}$$

where θ is the angle of the concrete compressive stress to the x-axis. The value of $\cot \theta$ shall be chosen to avoid compressive value of f_{id} .

Note:

- (1) In order to avoid unacceptable cracks for the serviceability state, and to ensure the required deformation capacity for the ultimate limit state, the reinforcement derived from Eq.9.8 and Eq. 9.9 for each direction should not be more than twice and not less than half the reinforcement determined by Eq. 9.2 and Eq. 9.3 or, alternatively, from Eq.9.5 and 9.6.

These limitations are expressed by $(1/2) f'_{idx} \leq f_{idx} \leq 2 f'_{idy}$ and $(1/2) f'_{idy} \leq f_{idy} \leq 2 f'_{idx}$

- (2) The reinforcement should be fully anchored at all free edges by following appropriate detailing, as described in Section 15.

9.4.2 *Simplified design for bending in orthogonal direction*

The slab (wall) subjected to orthogonal bending effects is substituted by two half plates usually representing the compression and tensile zones of the element.

The stresses in compressive portions are checked by verifying that the resultant principle compressive stress is within the allowable limits.

The half plate carrying tensile stresses in orthogonal directions is converted to orthogonal mesh of steel following method described in Clause 9.4.1.

The out of plane shear forces are similarly converted to principle bending directions and the maximum shear checked using methods of Section 10.

9.4.3 *Simplified design of combined in-plane forces and out of plane bending and shears*

The plate is substituted by a sandwiched plate of the same thickness consisting of three layers of 1/3rd thickness. The central 1/3rd thickness is designed to carry in-plane forces using methods of Clause 9.4.1.

The outer two layers are designed to resist tensile and compressive fields with appropriate lever-arm to develop resistance to bending and shear in two directions as per Clause 9.4.2.

SECTION 10

ULTIMATE LIMIT STATE OF SHEAR, PUNCHING SHEAR AND TORSION

10.1 Scope

This Section applies to design of flexural members for web shear, interface shear between the web and flanges, and torsion. The punching shear due to transverse concentrated loads/reactions acting over a small area is covered. Design verification for shear is carried out at Ultimate Limit State of strength only. The design of members requiring shear reinforcement is based on truss model. For members without shear reinforcement truss model is not applicable.

For concrete of grades higher than M60, the shear strength shall be limited to that of strength grade M60 for design purpose.

10.2 Design of Flexural Members for Shear

10.2.1 *Shear design model of members without shear reinforcement*

- (1) The design rules, given in Clauses below are based on extensive experimentation and not on any specific design model. These rules take into account the important parameters mentioned in (3) & (4) below by empirical approach.
- (2) Minimum shear reinforcement is required in this type of members to avoid sudden brittle failure induced by cracking in shear tension in webs. The minimum shear reinforcement may be omitted in members such as slabs where transverse redistribution of loads is possible.
- (3) Thin structural members like slabs cracked in flexure carry shear forces using shear strength of the uncracked compression zone, shear forces transferred across flexural cracks by mechanical interlock and dowel action of reinforcing steel. Members of thickness less than 200 mm develop higher shear strength than those having over 200 mm thickness.
- (4) The shear strength of rectangular section, T- section and L-section is mainly determined by:
 - Effective width of web b_w , depth d , ratio of b_w/d , and ratio of shear span to depth.
 - Properties of Concrete such as tensile strength, and mechanical interlock of cracked surfaces.
 - Ratio $\rho = A_s/b_w d$ of flexural tensile reinforcement to area of concrete.
 - Dowel action of reinforcement.

10.2.2 *Shear Design model of members with shear reinforcement*

10.2.2.1 *Zone of Shear design*

These elements subjected to bending and significant shear forces exhibit four zones as shown in **Fig. 10.1(a)** namely uncracked zone (Zone A); Zone with shear cracks in web without any flexural cracks (Zone B); Zone with combined flexural and shear cracks (Zone C, comprising Zones C1 & C2) and Zone with only flexural cracks (Zone D). The compression fields in concrete in these zones together

with the shear resistance provided by concrete cracks and the reinforcement, provide mechanism to carry shear forces to the support.

In Zone 'A', the type of support effects the compression field in concrete near the support.

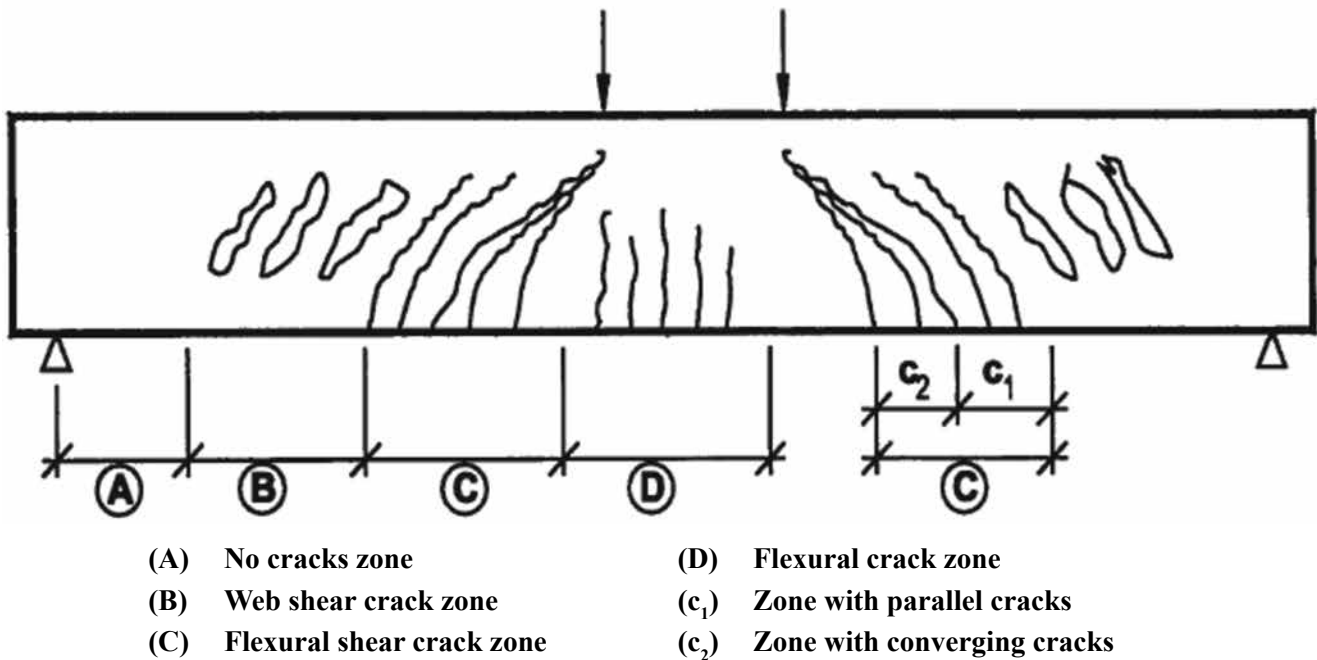

Fig. 10.1(a) Shear Zones of Flexural Members

In case of direct support [**Fig. 10.1 (b)**], a fan like compression field exists. When structure is subjected to predominantly uniformly distributed loads, in area, confined by the beam end and the steepest inclination ($\theta_{\max} = 45^\circ$) of the compression field (generally within a distance equal to effective depth from face of support or centre of bearing where flexible bearings are used), no shear reinforcement is required.

For concentrated loads the steepest inclination may be taken as 26.5° (measured with respect to vertical face of beam end, generally within a distance of half the effective depth from face of support) and for loads within this distance no shear reinforcement is required. It is however, necessary to extend the shear reinforcement up to the support from the section within this region 'X1' (distance d or half of d , as the case may be, see figure 10.1(b)) and provide tensile reinforcement, adequately anchored beyond bearing point, for resisting the horizontal components of these internal compressive forces in addition to the steel provided for bending.

In case of indirect support [**Fig.10.1(c)**], as a consequence of compatibility condition, a fan like compression field does not exist. For the design it is assumed on the safer side that the compressive stresses are distributed equally over the full depth of the section. Additionally, in the common intersection zone of the supporting and the supported beam, reinforcement is required over and above the shear reinforcement.

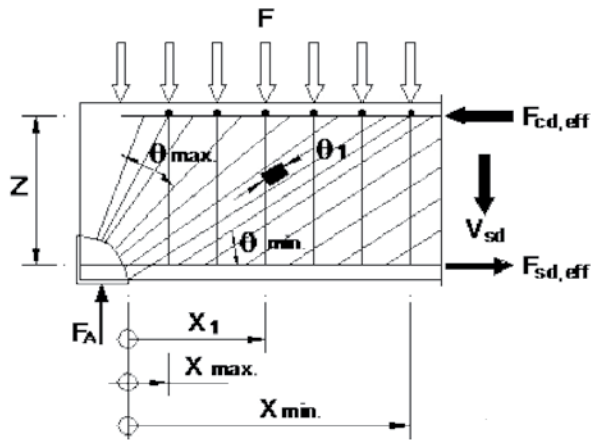

Fig. 10.1(b) Direct Support

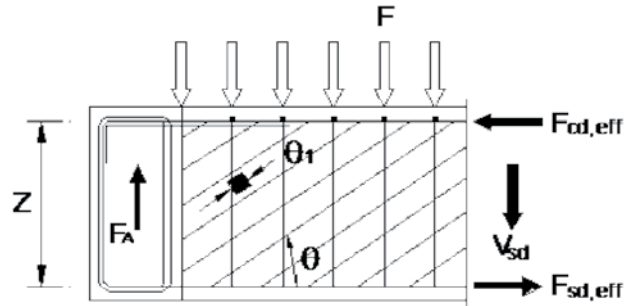

Fig. 10.1(c) Indirect Support

10.2.2.2 The shear transfer mechanism of truss model

(1) Beam with Constant Depth

The design of shear resistance of members is based on a truss model (Fig. 10.2) in which loads are transferred to the support by truss type action within the member. The compression chord, tension chord and web members comprising compression struts and tensile steel elements are the members of the truss. Angles θ and α are the inclinations of concrete compressive truss and reinforcement with the axis of the element as defined in Fig. 10.2(a). The angles may be chosen within limits such that:

$$1.0 \leq \cot \theta \leq 2.5 \text{ and } 45^\circ \leq \alpha \leq 90^\circ$$

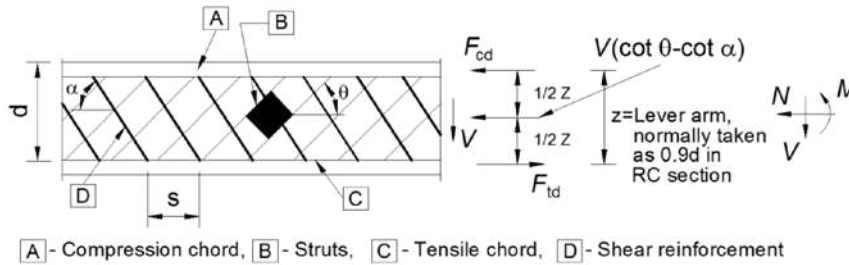

Fig.10.2(a)

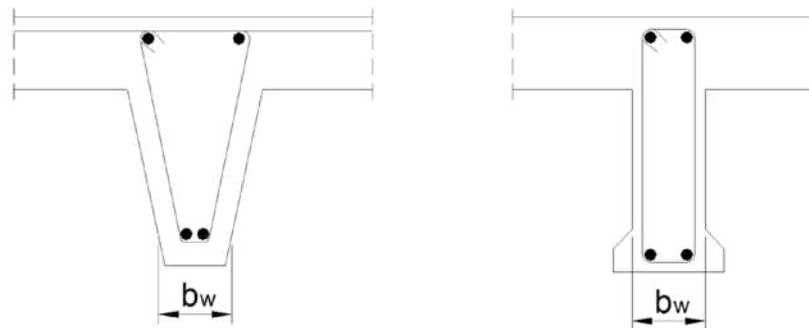

Fig.10.2(b)

Fig. 10.2 Truss Model and Notation for Members with Shear Reinforcement

(2) Beam of variable depth

A schematic truss model for beam with both tensile and compressive chords inclined to the central axis as shown in **Fig. 10.3** may be used for design of shear resistance. The forces in the chord and web may be determined on the basis of this or other suitable truss models.

As a simplification, local zones of short length of a beam with inclined chords may be designed using method given for beam with parallel chord. For this shear force to be carried by the web shall be corrected by taking into account the components of chord forces parallel to the shear force as shown in **Fig. 10.4**.

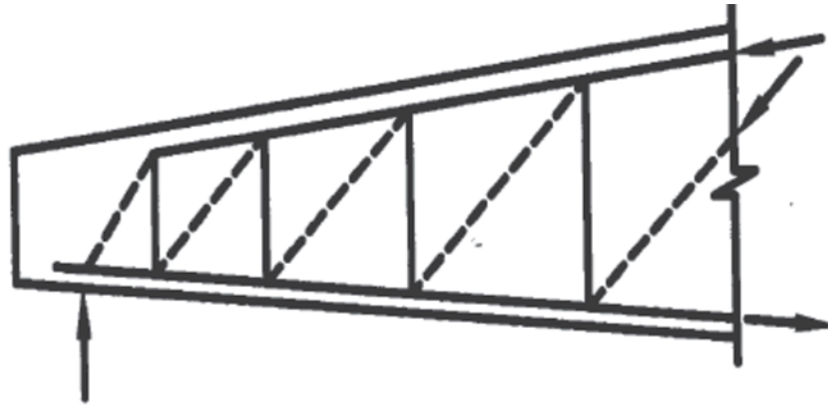

Fig 10.3 Model of a Beam of Varying Depth

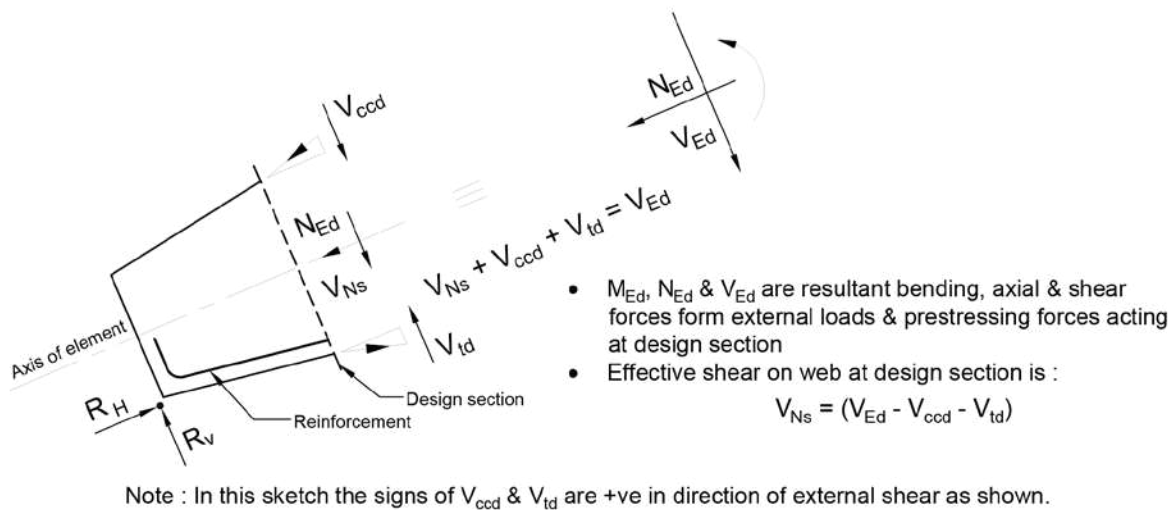

Fig 10.4 Shear Component for Members with Inclined Chords

10.2.3 Design shear force

- (1) In case of direct support, shear force V_{NS} acting at section d (effective depth) away from face of support (or centre of bearing where flexible bearings are used) when the member is subjected to predominantly uniformly distributed load and at a distance $d/2$ away when member is subjected to concentrated loads – may be used for design of shear reinforcement in the region between support to d or support to $d/2$ as the case may be. For checking crushing of concrete compression strut V_{NS} shall be taken at centre of support.

- (2) In case of indirect support, shear force shall be taken at face of the support both for design of reinforcement and checking compressive stresses.
- (3) In the elements of variable depth, where V_{Ed} , M_{Ed} , and N_{Ed} are concurrently acting forces, the design shear force V_{Ed} from sectional analysis shall be reduced by the favorable contribution from any inclined compression chord and tension chord as shown in **Fig. 10.4**. Any unfavorable contributions, depending on direction of inclination of chords shall be added to V_{Ed} . In **Fig. 10.4**, $V_{NS} = V_{Ed} - V_{ccd} - V_{td}$.
- (4) In case of prestressed members the design prestressing force is considered as external load in the analysis and is accounted for in the analysis of the sectional shear V_{NS} including its hyperstatic effects in case of indeterminate members.
Further increase in force in bonded tendons due to cracking of concrete under ULS load only is to be included in the analysis of shear resistance of truss in the same way as that of untensioned reinforcement.
In case of pretensioned members the reduction in the maximum developable force under UTS in prestressing tendons within development length shall be taken into account.
- (5) For members not requiring shear reinforcement the net design force shall be taken as V_{Ed} ignoring components of inclined chords and increase in bonded prestressing force.

10.3 Design Method

10.3.1 Notation

For verification of shear resistance, the following additional notations over those given in Section 3 are required:

$V_{Rd,c}$	The design shear resistance of the member without shear reinforcement.
$V_{Rd,max}$	The design value of maximum shear force which can be sustained by the member limited by crushing of the compression struts.
$V_{Rd,s}$	The design value of the shear force which can be sustained by the yielding shear reinforcement.
V_{ccd}	Design value of the shear component of the force in the compression area, in the case of an inclined compression chord.
V_{td}	Design value of the shear component of the force in the tensile reinforcement, in the case of an inclined tensile chord.
V_{Rd}	The shear resistance of a member with shear reinforcement \approx Minimum of $(V_{Rd,s}; V_{Rd,max}) + V_{ccd} + V_{td}$
V_{Ed}	The design shear force at a cross-section resulting from external loading and that due to prestressing (V_{pd}) (bonded or unbonded tendon)
V_{NS}	Net Design Shear Force = Algebraic sum of V_{ED} , V_{ccd} and V_{td}
V_{pd}	Shear component of prestressing tendon

The following notations are adopted in the expressions given hereafter

$K=$	$1 + \sqrt{\frac{200}{d}} \leq 2.0$ where d is depth in millimeters
b_w	Minimum breadth of the section over the depth (Fig. 10.2)
b_{wc}	Width of the cross-section at the centroidal axis, allowing for the presence of ducts as per Eq.10.14 or 10.15, as applicable.
A_{sl}	Area of the tensile reinforcement which extends not less than $(l_{bd}+d)$ beyond the considered section [Fig. 10.5]
A_{sc}	Area of untensioned and tensioned steel in compression zone.
A_{sw}	Area of shear reinforcement at a section
S	First moment of area between centroidal axis and extreme compression fibre about the centroidal axis
I	Second moment of area of the gross cross-section
M_{Ed}	Design value of the applied internal bending moment
N_{Ed}	Applied longitudinal force in the section due to loading or prestressing with proper load factor (compressive force shall be taken as positive). The influence of imposed deformations on N_{Ed} may be ignored.
F_s	Tensile force in the longitudinal reinforcement
F_c	The compression force in the concrete in the direction of the longitudinal axis
σ_{cp}	Concrete compressive stress at the centroidal axis due to axial loading or prestressing
f_{ywd}	Design strength of web reinforcement to resist shear $= f_{yk} / \gamma_m$
f_{cd}	Design value of concrete compression strength $= \alpha_{cc} \cdot f_{ck} / \gamma_m$, where $\alpha_{cc} = 0.67$
f_{ctd}	Design value of concrete tensile strength (f_{ctk} / γ_m)
f_{ctk}	Characteristic axial tensile strength of concrete (5 percent fractile)
s	Spacing of shear reinforcement
ρ_l	$\rho_l = \frac{A_{sl}}{b_w d} \leq 0.02$
ρ_w	$\rho_w = \frac{A_{sw}}{s \cdot b_w \cdot \sin \alpha}$ where α is as defined in Fig. 10.2(a) .
k_l	$l_x / l_{pt2} \leq 1.0$ for pre-tensioned tendons, for other types of prestressing $k_l = 1$. l_x is the distance of section considered from the starting point of the transmission length l_{pt2} is the upper bound value of the transmission length of the prestressing element, $l_{pt2} = 1.2 l_{pt}$ (for l_{pt} & l_{pt2} refer Eq.15.9 & Eq. 15.10, Section 15)
α_{cw}	Constant as defined below

For structural element having no axial force $\alpha_{cw} = 1$

For Structural element having axial force

Where $0 < \sigma_{cp} \leq 0.25f_{cd}$

$$\alpha_{cw} = (1 + \sigma_{cp} / f_{cd})$$

Where $0.25f_{cd} < \sigma_{cp} \leq 0.5f_{cd}$

$$\alpha_{cw} = 1.25$$

Where $0.5f_{cd} < \sigma_{cp} \leq 1.0f_{cd}$

$$\alpha_{cw} = 2.5(1 - \sigma_{cp} / f_{cd})$$

When:

σ_{cp} is the mean compressive stress, measured positive, in the concrete due to the design axial force. This should be obtained by averaging it over the concrete section taking account of the reinforcement. The value of σ_{cp} need not be calculated at a distance less than $0.5d \cot \theta$ from the edge of the support.

$v_l = v$ is a strength reduction factor for concrete cracked in shear, given in Eq. 10.6

10.3.2 Elements not requiring design shear reinforcement

(1) The design shear resistance $V_{Rd,c} \geq V_{Ed}$

(2) The design shear resistance of the member without shear reinforcement $V_{Rd,c}$ is given by:

$$V_{Rd,c} = \left[0.12K(80\rho_1 \cdot f_{ck})^{0.33} + 0.15\sigma_{cp} \right] b_w \cdot d$$

Subject to a minimum of $V_{Rd,c} = (v_{min} + 0.15 \sigma_{cp}) b_w d$ **Eq. 10.1**

$K = 1 + \sqrt{\frac{200}{d}} \leq 2.0$ where d is depth in millimeters. **Eq. 10.2**

and $v_{min} = 0.031K^{3/2} f_{ck}^{1/2}$ **Eq. 10.3**

σ_{cp} is limited to $0.2f_{cd}$ (MPa) where $\sigma_{cp} = N_{Ed} / A_c < 0.2f_{cd}$ (MPa)

$$\rho_1 = \frac{A_{sl}}{b_w \cdot d} \leq 0.02 \quad \text{(Fig. 10.5)}$$

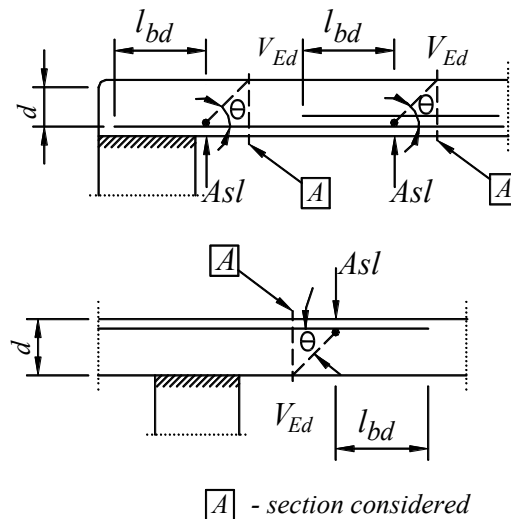

Fig. 10.5 Definition of A_{sl} in Expression ρ_1

A_{sl} is the tensile reinforcement which extends by length greater than $l_{bd} + d$ beyond section considered **(Fig. 10.5)**

- (3) In prestressed single span members without design shear reinforcement both Zone B and Zone C may exist. For Zone C, cracked in bending the expression for $V_{Rd.c}$ as given in Eq 10.1 can be used. For Zone B uncracked in bending, where flexural tensile stress in the region under maximum bending moment is smaller than $f_{ctk\ 0.05}/\gamma_m$, the shear resistance should be limited by the tensile strength of concrete. In these regions the shear resistance is given by

$$V_{Rd.c} = \frac{I_{bc}}{s} \sqrt{(f_{ctd})^2 \pm k_1 \sigma_{cp} f_{ctd}} \quad \text{Eq. 10.4}$$

Where notations are as per Section 10.3.1

For cross-sections where the width varies over the height, the maximum principal stress may occur on an axis other than the centroidal axis. In such a case the minimum value of the shear capacity should be found by calculating $V_{Rd.c}$ at various axes in the cross-sections.

- 4) The calculation of the shear resistance according to the Eq. 10.4 is not required for cross-sections between the support and the section which contains the intersection of the elastic centroidal axis and a line inclined from the inner edge of the support at an angle of 45° .
- 5) For members with concentrated loads applied on the upper side at a distance av where av is within $0.5d$ to $2d$ from the edge of a support (or centre of bearing where flexible bearings are used), the contribution of this load to the shear force V_{Ed} may be multiplied $\beta = av/2d$. This reduction may be applied for checking $V_{Rd.c}$ in Eq.10.1. This is only valid provided that the longitudinal reinforcement is fully anchored at the support. For $av \leq 0.5d$, the value of $av = 0.5d$ should be used.

The shear force V_{Ed} , calculated without reduction by β should however always satisfy the condition.

$$V_{Ed} < 0.5b_w dvf_{cd} \quad \text{Eq. 10.5}$$

where v is a strength reduction factor for concrete cracked in shear.

$$v = 0.6 \left[1 - \frac{f_{ck}}{310} \right] \text{ where } f_{ck} \text{ is in MPa} \quad \text{Eq. 10.6}$$

- (6) For the design of longitudinal reinforcement in the region cracked in flexure, the M_{Ed} line shall be shifted over a distance $\alpha_l = d$ in the unfavourable direction (Ref. Section 16.5.1.3 and **Fig. 16.2**).

10.3.3 Members requiring design shear reinforcement ($V_{Rdc} < V_{ED}$)

10.3.3.1 Shear resistance

- (1) The shear resistance of concrete flexural element in a truss model is dependent on the longitudinal reinforcement provided in the tension zone. For full effectiveness at the design section of shear, the longitudinal reinforcement shall extend not less than $\Delta L = d \cot \theta + l_{bd}$ beyond the section considered where ' d ' is the effective depth and l_{bd} the anchorage length (**Fig. 10.5**). The area of bonded prestressing steel may be included.
- (2) Failure ascribable to web compression will be sudden and hence shall be avoided.
- (3) The shear at the interface between concrete cast at different times requires additional precautions as detailed in Clause 10.3.4.

- (4) To find the least amount of shear reinforcement, for low and intermediate shear stresses, the lower limits of θ given in Clause 10.2.2.2 will normally govern the design. For higher shear stresses, the value of θ may be found by equating the design shear force V_{NS} to $V_{Rd,max}$. The amount of shear reinforcement is then found by equating the design shear force V_{NS} to $V_{Rd,s}$. The value of θ may alternatively be selected to optimize the design, for example by minimizing the total amount of reinforcement.

10.3.3.2 Members with vertical shear reinforcement

- (1) For members with vertical shear reinforcement, the shear resistance is the smaller value of:

$$V_{Rd,s} = \frac{A_{sw}}{s} z f_{ywd} \cot \theta \quad \text{Eq. 10.7}$$

and

$$V_{Rd,max} = \alpha_{cw} b_w z v_1 \frac{f_{cd}}{(\cot \theta + \tan \theta)} \quad \text{Eq. 10.8}$$

where

- A_{sw} is the cross sectional area of the shear reinforcement
 s is the spacing of the stirrups
 f_{ywd} is the design strength of web reinforcement to resist shear (and torsion)
 $= \frac{f_{yk}}{\gamma_m}$ while the value of f_{yk} is limited to 500 MPa.
 $v_l = v$ is a strength reduction factor for concrete cracked in shear given in Eq. 10.6.
 z lever arm can be taken as 0.9d for RCC section and to be calculated for PSC section.

For sections which are under full compression under moment, and the compressive force in the less compressive chord is at least equal to $\Delta F_{td} - 1/3$ of compressive force in the web, z shall be taken as 0.9 times of total depth.

For calculating the compressive force in the less compressive chord, the area of this chord shall be assumed as follows:

- in case of box girder the area of soffit
- in case of T beam with bulb, the area of bulb
- in case of voided slabs the soffit area (area below void)
- in case there is no defined chord available for less compressive chord then it shall be taken as zero, e.g. T Beam without bulb

α_{cw} is coefficient taking account of the state of the stress in the compression chord:

$$\begin{aligned} \alpha_{cw} &= 1 && \text{for } \sigma_{cp} = 0 \\ &1 + \sigma_{cp}/f_{cd} && \text{for } 0 < \sigma_{cp} \leq 0.25 f_{cd} \\ &1.25 && \text{for } 0.25 f_{cd} \leq \sigma_{cp} < 0.5 f_{cd} \\ &2.5 (1 - \sigma_{cp}/f_{cd}) && \text{for } 0.5 f_{cd} < \sigma_{cp} < 1.0 f_{cd} \end{aligned} \quad \text{Eq. 10.9}$$

where

σ_{cp} = is the mean compressive stress, measured positive, in the concrete due to the design axial force. This should be obtained by averaging it over the concrete section taking account of the reinforcement. The value of σ_{cp} need not be calculated at a distance less than $0.5d \cot \theta$ from the edge of the support.

Note : The maximum effective cross-sectional area of the shear reinforcement, $A_{sw,max}$ for $\cot \theta=1$ is given by:

$$\frac{A_{sw,max} f_{ywd}}{b_w s} \leq \frac{1}{2} \alpha_{cw} v_1 f_{cd} \quad \text{Eq. 10.10}$$

- (2) The sub clause 10.3.3.3(4) to (8) will also be applicable for members provided with vertical shear reinforcement where α is taken as 90° .

10.3.3.3 Members with inclined shear reinforcement

- (1) For members with inclined shear reinforcement, the shear resistance is the smaller value of :

$$V_{Rd,s} = \frac{A_{sw}}{s} z f_{ywd} (\cot \theta + \cot \alpha) \sin \alpha \quad \text{Eq. 10.11}$$

and

$$V_{Rd,max} = \alpha_{cw} b_w z v_1 f_{cd} (\cot \theta + \cot \alpha) / (1 + \cot^2 \theta) \quad \text{Eq. 10.12}$$

Note: The maximum effective shear reinforcement, $A_{sw,max}$ for $\cot \theta = 1$ follows from:

$$\frac{A_{sw,max} f_{ywd}}{b_w s} \leq \frac{\frac{1}{2} \alpha_{cw} v_1 f_{cd}}{\sin \alpha} \quad \text{Eq. 10.13}$$

- (2) Bent up bars shall not be used as shear reinforcement except in combination with vertical stirrups. At least 50 percent of V_{Ns} shall be resisted by vertical stirrups.
- (3) For inclined shear reinforcement, the angle between the reinforcement and the longitudinal axis of the beam α should not be less than 45° .
- (4) In regions where there is no discontinuity of V_{Ed} (e.g. for uniformly distributed loading) the shear reinforcement in any length increment $l = z (\cot \theta + \cot \alpha)$ may be calculated using the smallest value of V_{Ed} in the increment.
- (5) Where the web contains grouted ducts with a diameter $\phi < b_w / 8$ the shear resistance $V_{Rd,max}$ should be calculated on the basis of a nominal web thickness given by:

$$b_{w,nom} = b_w - 0.5 \sum \Phi \quad \text{Eq. 10.14}$$

where ϕ is the outer diameter of the duct and $\sum \phi$ is determined for the most unfavourable level.

For grouted metal ducts with $\phi \leq b_w / 8$, $b_{w,nom} = b_w$

For non-grouted ducts and unbonded tendons the nominal web thickness is:

$$b_{w,nom} = b_w - 1.2 \Sigma \Phi \tag{Eq. 10.15}$$

The value 1.2 in Eq.10.15 is introduced to take account of splitting of the concrete struts due to transverse tension. If adequate transverse reinforcement is provided this value may be reduced to 1.0

For grouted plastic ducts the nominal web thickness is:

$$b_{w,nom} = b_w - 0.8 \Sigma \Phi \tag{Eq.10.15a}$$

- (6) The additional tensile force, ΔF_{td} in the longitudinal reinforcement due to shear V_{ED} shall be provided in the tensile chord and may be calculated from:

$$\Delta F_{td} = 0.5 V_{Ed} (\text{Cot}.\theta - \text{Cot}.\alpha) \tag{Eq. 10.16}$$

$\frac{M_{Ed}}{z} + \Delta F_{td}$ should be taken not greater than $\frac{M_{Ed,max}}{z}$ where $M_{Ed,max}$ is the maximum moment along the beam.

In case of prestressed members the spare capacity in prestressing cable if available can be used to account for this requirement.

- (7) For members with concentrated loads applied on the upper side within a distance $0.5 \leq a_v \leq 2d$ the Contribution of this load to the shear force V_{Ed} may be reduced by $\beta = a_v / 2d$.

- (8) The shear force V_{Ed} calculated in this way, should satisfy the condition

$$V_{Ed} \leq A_{sw} f_{ywd} \sin \alpha \tag{Eq. 10.17}$$

Where $A_{sw} f_{ywd}$ is the resistance of the shear reinforcement crossing the inclined shear crack between the loaded areas (refer Fig. 10.6). Only the shear reinforcement within the central $0.75 a_v$ should be taken into account. The reduction of β should only be applied for calculating the shear reinforcement. It is only valid provided the longitudinal reinforcement is fully anchored at the support.

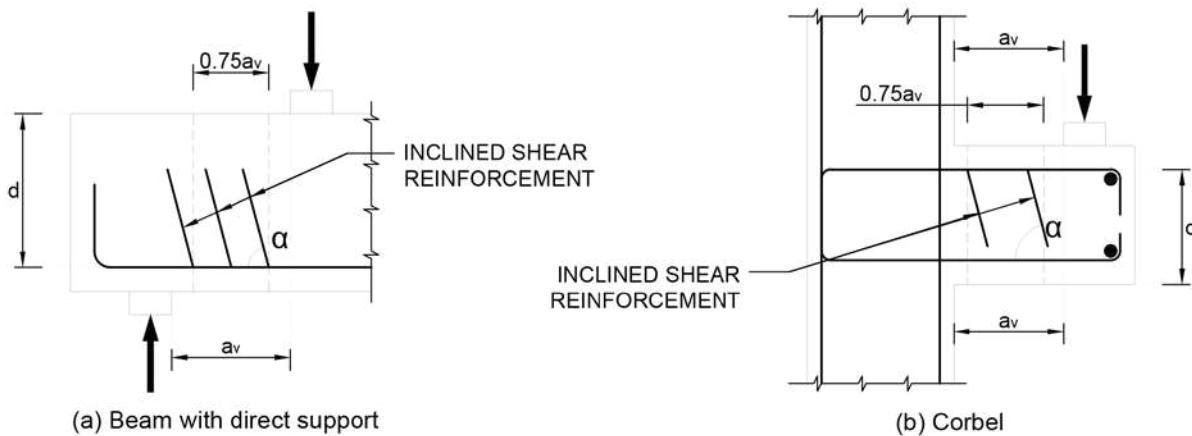

Fig. 10.6 Loads Near Supports and Shear Reinforcement with Direct Strut Action

- Note 1 Beams with loads near to supports and corbels may alternatively be designed with strut and tie models.
 Note 2 Where the load is not acting at the top of the beam, or when the support is not at the bottom of the beam, suspension reinforcement should be provided to transfer the load to the top of the design truss system.

10.3.3.4 Diagonal stress fields for members having unbonded tendon

- (1) Sections having both bonded and unbonded tendons shall be treated as in Clause 10.3.3 making use of only bonded tendons as reinforcement.
- (2) In the case of precast elements joined by unbonded prestressing tendons in the tension chord (e.g. segmental construction), the section at ULS may act as tied arch with joints partially opening. This effect of opening of joints on shear resistance should be considered. Under these conditions, in absence of detailed analysis, the force in the tension chord, provided by the unbonded tendons should be assumed to remain unchanged after the joints have opened. In consequence, as the applied load increases and joints open further, the inclination of concrete strutt within the web increases. The depth of concrete section available for the flow of the web compression decreases to a value of h_{red} . (Refer **Fig. 10.7**)

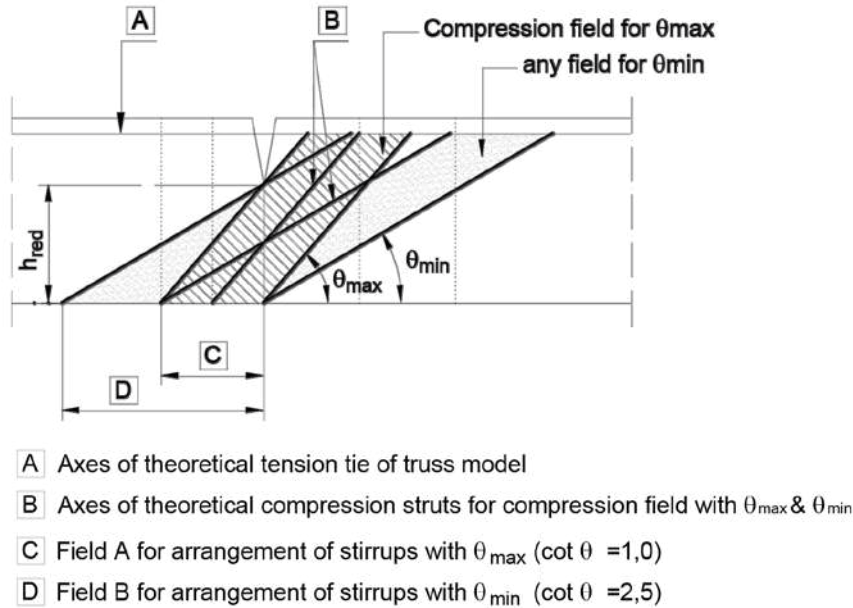

Fig. 10.7 Diagonal Stress Fields Across the Joint in the Web

The shear capacity can be evaluated in accordance with Eq.10.7 and Eq.10.11 as applicable, by assuming a value of θ derived from the minimum value of residual depth h_{red} .

$$h_{red} = \frac{V_{NS}}{b_w \cdot v \cdot f_{cd}} (\cot \theta + \tan \theta) \quad \text{Eq. 10.18}$$

Shear reinforcement stirrups, having the following area (Eq. 10.19) per unit length should be provided within a distance $h_{red} \cot \theta$, but not greater than the segment length, from both edges of the joint.

$$\frac{A_{sw}}{s} = \frac{V_{NS}}{h_{red} f_{ywd} \cot \theta} \quad \text{Eq. 10.19}$$

The prestressing force should be increased, if necessary, such that at the ultimate limit state under the combination of bending moment and shear, the joint opening is limited to the value $h - h_{red}$. The value of h_{red} shall be more than $0.5h$.

10.3.3.5 Minimum shear reinforcement

For beams, minimum shear reinforcement ratio (ρ_{min}) shall be

$$\rho_{min} = \frac{0.072\sqrt{f_{ck}}}{f_{yk}} \quad \text{Eq. 10.20}$$

10.3.4 Interface Shear

The shear stress that arises between the interfaces of concrete placed at different times is referred to as interface shear.

Precast beam with cast-in-situ slab is one of the typical case where interface shear has to be designed for.

The interface shear is resisted by friction at the interface and by reinforcement placed across the shear plane.

The interface shear stress should satisfy the following:

$$v_{Edi} \leq v_{Rdi}$$

where

v_{Edi} is the interface shear stress

$$v_{Edi} = \beta V_{Ed} / Z.b_i$$

β is the ratio of the longitudinal force in the new concrete and the total longitudinal force.

V_{Ed} is the transverse shear force.

Z is the lever arm and

b_i is the width of the interface

v_{Rdi} is the resisting capacity at the section.

$$v_{Rdi} = \mu\sigma_n + \rho f_{yd} [\mu \sin \alpha + \cos \alpha] \leq 0.5v_{fd} \quad \text{Eq. 10.21}$$

Where μ is roughness coefficient

In the absence of more detailed information, surfaces may be classified as very smooth, smooth, rough or indented, with the following examples:

Very smooth : a surface cast against steel, plastic or specially prepared wooden moulds: $\mu = 0.5$

Smooth : a slip formed or extruded surface, or a free surface left without further treatment after vibration : $\mu = 0.6$

Rough a surface with at least 3 mm roughness at about 40 mm spacing achieved by raking, exposing of aggregate or other methods giving an equivalent behaviour : $\mu = 0.7$

Indented : a surface with indentations complying with **Fig. 10.8**: $\mu=0.9$

α is the angle of the reinforcement to the interface.

σ_n is the minimum coexisting normal stress $< 0.6 f_{cd}$
 $\rho = A_s/A_i$ where A_s is the area of reinforcement crossing the joint A_i is the interface area of the joint.

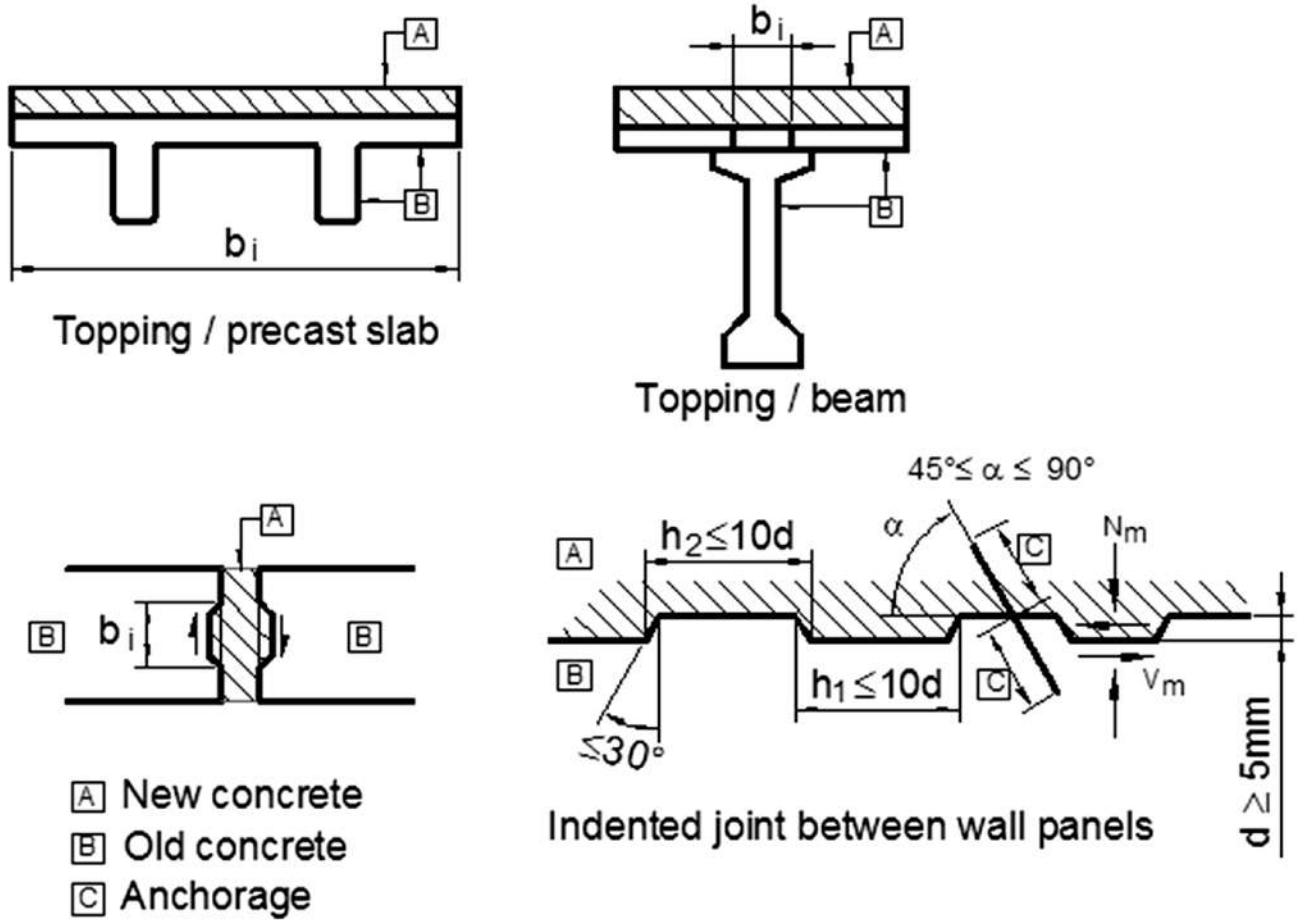

Fig. 10.8 Typical cases of Interfaces for Shear

Minimum reinforcement across the horizontal interface to resist the interface shear shall be 0.15 percent of interface area

10.3.5 Shear in the flange portion of flanged beams and box sections

Flexural compression and tension is carried mainly by the flanges and the variation of flexure leads to shear at the junction of flanges with the webs. The flanges also will be subjected to shear flow in their own plane. The design for this shear is based on a truss model in the plane of the flanges with compression struts and tensile reinforcement (Fig. 10.9).

- (1) The longitudinal shear stress $v_{Ed,f}$ at the junction between one side of flange and the web is determined by the change of normal (longitudinal) force in a definite distance.

$$v_{Ed,f} = \left[\frac{\Delta F_d}{h_f \cdot \Delta x} \right] \tag{Eq. 10.22}$$

where h_f , is the thickness of flange at the junction of the flange and the web
 ΔX is the length under consideration,

ΔF_d is the change of the normal force in the flange over the length ΔX

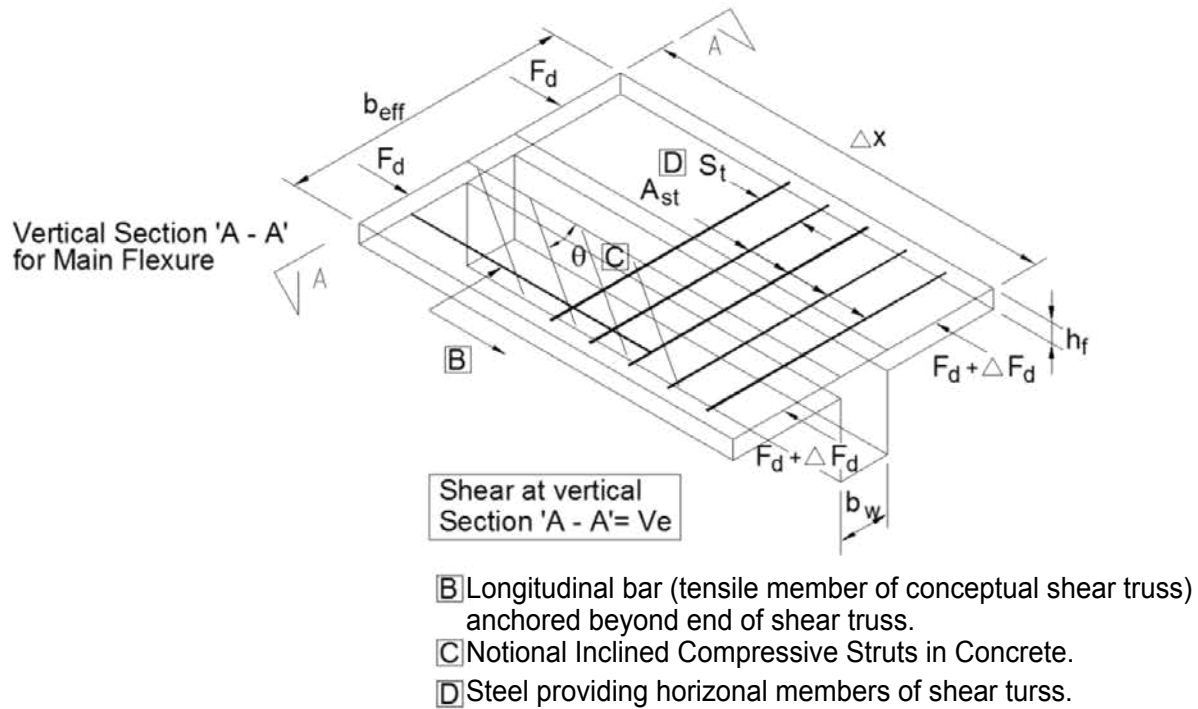

Fig. 10.9 Shear Design Between Flange & Web of Compression Flange (Tension slab has similar truss with direction of $F_1, F + \Delta F$ reversed)

(2) The transverse reinforcement per unit length $\frac{A_{sf}}{s_f}$ may be determined as follows:

$$\frac{A_{sf}}{s_f} = \frac{v_{Edf} \cdot h_f}{f_{yd} \cot \theta_f}$$

Eq. 10.23

For verification of concrete compression h_f , should be reduced by the depth of concrete compression zone in transverse bending.

To prevent crushing of the compression struts in the flange, the following condition should be satisfied

$$v_{Edf} < v_{cd} \sin \theta_f \cdot \cos \theta_f$$

Note: The recommended values in the absence of more rigorous calculation are:

$$1.0 \leq \cot \theta_f \leq 2.0 \text{ for compression flanges } (45^\circ \geq \theta_f \geq 26,5^\circ)$$

$$1.0 \leq \cot \theta_f \leq 1.25 \text{ for tension flanges } (45^\circ \geq \theta_f \geq 38,6^\circ)$$

(3) In the case of combined shear between the flange and the web, and transverse bending, the area of steel should be the greater of that given by Eq.10.23 or half that given in Eq. 10.23 plus that required for transverse bending.

(4) If v_{Edf} is less than or equal to $0.4f_{cd}$ no extra reinforcement above that for flexure is required.

(5) Longitudinal tension reinforcement in the flange should be anchored beyond the strut required to transmit the force back to the web at the section where this reinforcement is required (Refer **Fig. 10.9**).

10.4 Design for Punching Shear

10.4.1 General

The rules in this Section are complementary to those given in earlier Sections. This Section covers shear due to punching force (penetrating force) on two dimensional structural elements such as deck slabs, soffit slab, well caps and open foundations. The word ‘slab’ represents all these in Clause 10.4.

The punching normally happens when a concentrated force (load or reaction) acts over a small area of the two dimensional structural element and causes local shear failure surrounding the concentrated force in the element.

10.4.2 Loaded area and basic control perimeter

- (1) Punching shear is evaluated as shear stress at (a) face of the loaded area u_0 (b) along basic control perimeter u_1 and (c) other perimeters as required in Clause 10.4.2(4).
- (2) The basic control perimeter u_1 shall be taken at distance $2d$ from the face of the loaded area (Refer **Fig. 10.10**) where the depth d of the element is taken as $d=(d_x+d_y)/2$; d_x and d_y being effective depths in two orthogonal directions measured at the control perimeter.

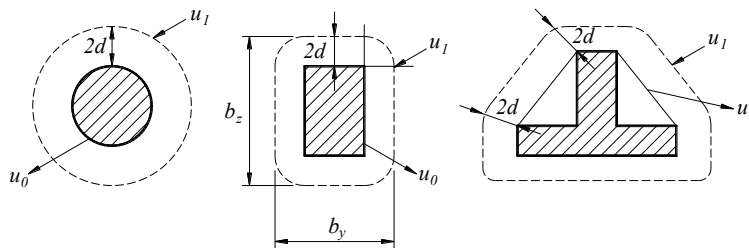

Fig. 10.10 Typical Basic Control Perimeters around Loaded Areas

- (3) For a loaded area situated near an edge, on the edge or at a corner, the control perimeter should be taken as shown in **Fig. 10.11**. In such cases special edge reinforcement shall be provided, as per Clause 16.6.1.4.
- (4) Control perimeters at a distance less than $2d$ should be considered for checking punching shear where the concentrated force of loaded area is partly resisted by a high pressure such as soil pressure on a base (e.g. foundation slab/raft) or by effects of a reaction or load within a distance of $2d$ of the periphery of the area of application of force such as pile caps. (Refer Clause 10.4.5).

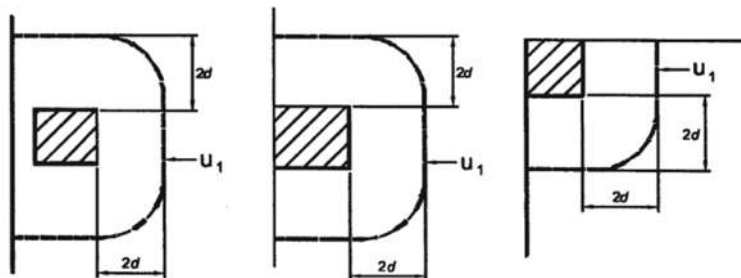

Fig. 10.11 Control Perimeters for Loaded Areas Close to or at Edge or Corner

10.4.3 *Punching Shear Stress*

(1) General

Punching shear stress v_{Ed} on any control perimeter under consideration is given by

$$v_{Ed} = \frac{\beta V_{Ed}}{u_i d} \tag{Eq. 10.24}$$

where

u_i is the length of the perimeter under consideration.

β = Factor accounting for effect of bending moment and axial load acting on loaded area.

$\beta = 1$ for axial load without bending moment, and

$$\beta = 1 + k (M_{Ed}/V_{Ed})(u_i/W_1) \text{ for axial load and bending moment} \tag{Eq. 10.25}$$

Where

u_i is the length of the basic control perimeter.

k is a coefficient dependent on the ratio between the column dimensions C_1 and C_2 ; its value is a function of the proportions of the unbalanced moment transmitted by uneven shear and by bending as shown in Table of **Fig. 10.12**.

W_1 is a property which corresponds to a distribution of shear as illustrated in **Fig.10.12** and is a function of the basic control perimeter u_i ; and the axis about which the moment is considered.

$$W_1 = \int_0^{u_i} |e| dl \tag{Eq. 10.26}$$

dl is the length increment of the perimeter

e is the distance of dl from the axis about which the moment M_{Ed} acts.

(2) For rectangular interior column

$$W_1 = 0.5(c_1)^2 + c_1 c_2 + 4c_2 d + 16d^2 + 2\pi d c_1 \tag{Eq. 10.27}$$

where

c_1 is column dimension parallel to the eccentric load

c_2 is column dimension perpendicular to the eccentricity of the load.

Value of k for Rectangular Loaded Areas				
c_1 / c_2	≤ 0.5	1.0	2.0	≥ 3.0
k	0.45	0.6	0.7	0.8

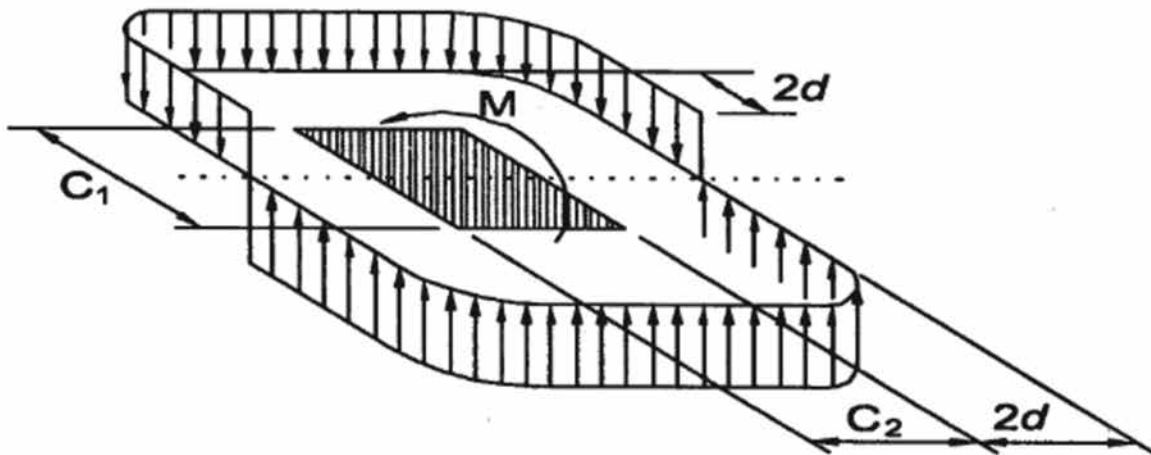

Fig. 10.12 Shear Distribution Due to Moment

For an internal rectangular column where the loading is eccentric to both axes, the approximate value of β is given by :

$$\beta = 1 + 1.8 \sqrt{\left(\frac{e_y}{b_z}\right)^2 + \left(\frac{e_z}{b_y}\right)^2} \quad \text{Eq. 10.28}$$

Where

e_y and e_z are the eccentricities $\frac{M_{Ed}}{V_{Ed}}$ along y and z axes respectively (Fig. 8.3)

b_y and b_z is the dimensions of the control perimeter (Fig. 10.10).

Note: e_y results from a moment about the z axes and e_z from a moment about the y axis.

(3) For internal circular column:

$$\beta = 1 + 0.6\pi \left(\frac{e}{D + 4d}\right) \quad \text{Eq. 10.29}$$

Where D is the diameter of the circular column.

(4) For edge column connections, where the eccentricity perpendicular to the slab edge (resulting from a moment about an axis parallel to the slab edge) is toward the interior. and there is no eccentricity parallel to the edge, the punching force may be considered to be uniformly distributed along the reduced control perimeter u_2 , as shown in Fig. 10.13(a).

Where there are eccentricities in both orthogonal directions, β may be determined using the following expression:

$$\beta = \frac{u_1}{u_2} + k \left(\frac{u_1}{W_1}\right) e_{par} \quad \text{Eq. 10.30}$$

Where

u_1 is the basic control perimeter (Fig. 10.11)

u_2 is the reduced basic control perimeter, refer Fig. 10.13(a).

- e_{par} is the eccentricity parallel to the slab edge resulting from a moment about an axis perpendicular to the slab edge.
- k may be determined with the ratio c_1/c_2 replaced by $c_1/2c_2$
- W_1 is a property calculated for the basic control perimeter u_1

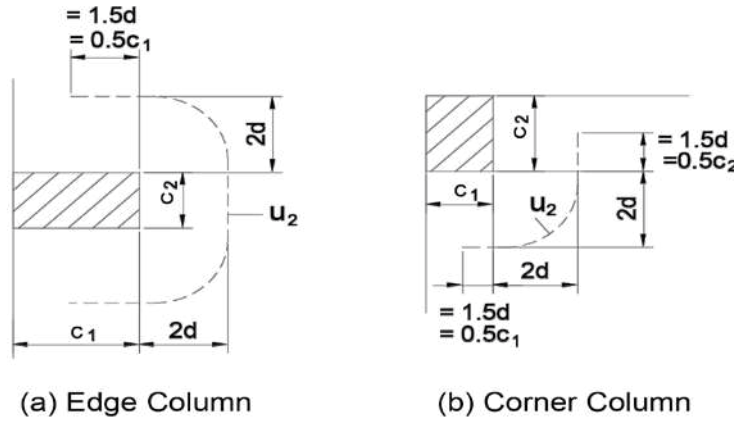

Fig. 10.13 Reduced Basic Control Parameters u_1 for Loaded Areas Close to Edge or at Corner

For a rectangular column as shown in **Fig. 10.13(a)**.

$$W_1 = \frac{c_2^2}{4} + c_1c_2 + 4c_1d + 8d^2 + \pi dc_2 \tag{Eq. 10.31}$$

If the eccentricity perpendicular to the slab edge is not toward the interior, Eq.10.25 applies. When calculating W_1 the eccentricity e should be measured from the centroid of the control perimeter.

- (5) For corner column, where the eccentricity is toward the interior of the slab, it is assumed that the punching force is uniformly distributed along the reduced control perimeter u_2 , as defined in **Fig. 10.13(b)**. The β - value may then be considered as:

$$\beta = \frac{u_1}{u_2} \tag{Eq. 10.32}$$

If the eccentricity is toward the exterior, Eq.10.25 applies.

The value of W_1 will change depending upon the axis about which the bending moment acts.

10.4.4 Punching shear resistance of slabs without shear reinforcement

The design punching shear resistance shall be assessed at the basic control perimeter, according to Clause 10.4.2. The design punching shear resistance [MPa] of slab may be calculated as follows:

$$v_{Rd.c} = \frac{0.18}{\gamma_c} K(80\rho_l f_{ck})^{1/3} + (0.1\sigma_{cp}) \geq v_{min} + 0.1\sigma_{cp} \tag{Eq. 10.33}$$

where

f_{ck} is in MPa

$$K = 1 + \sqrt{\frac{200}{d}} \leq 2.0 \quad \text{where } d \text{ is depth in millimeters.} \quad \text{Eq. 10.34}$$

$$\rho_l = \sqrt{\rho_{ly} \cdot \rho_{lz}} \leq 0.02 \quad \text{Eq. 10.35}$$

ρ_{ly} & ρ_{lz} relate to the bonded tension steel in y – and z – directions respectively. The values ρ_{ly} and ρ_{lz} should be calculated as mean values taking into account a slab width equal to the column width plus $3d$ each side.

$$\sigma_{cp} = \frac{(\sigma_{cy} + \sigma_{cz})}{2} \quad \text{Eq. 10.36}$$

where

σ_{cy} , σ_{cz} are the axial concrete stresses in the critical section and directions in MPa, (positive if compression):

$$\sigma_{cp} = \frac{N_{Ed,y}}{A_{cy}} \text{ and } \sigma_{c,z} = \frac{N_{Ed,z}}{A_{cz}} \quad \text{Eq. 10.37}$$

$N_{Ed,y}$, $N_{Ed,z}$ are the longitudinal forces. The force may be from a load of prestressing action.

A_{cy} , A_{cz} are the area of concrete resisting axial forces.

10.4.5 *Punching shear for foundation slabs and pile caps*

(1) The punching resistance of column bases for open foundations and pile caps should be verified at the face of the column and at control perimeters within $2d$ from the periphery of the column.

(2) For concentric loading the net applied force is

$$V_{Ed,red} = V_{Ed} - \Delta V_{Ed} \quad \text{Eq. 10.38}$$

Where

V_{Ed} is the applied shear force

ΔV_{Ed} is the net upward force within the control perimeter considered, i.e. upward pressure from soil minus self-weight of base.

$$v_{Ed,red} = \frac{V_{Ed,red}}{ud} \quad \text{Eq. 10.39}$$

$$v_{Rd} = \left[0.12k (80\rho_l f_{ck})^{\frac{1}{3}} \right] \times \frac{2d}{a} \geq v_{\min} \times \frac{2d}{a} \quad \text{Eq. 10.40}$$

Where

v_{Rd} is punching shear resistance at control perimeter at distance a

a is the distance from the periphery of the column to the control perimeter considered.

$$K = 1 + \sqrt{\frac{200}{d}} \leq 2.0 \quad \text{d in mm as defined in Eq. 10.34}$$

$$v_{min} = 0.031k^{3/2}f_{ck}^{1/2} \quad \text{Eq. 10.41}$$

(3) For eccentric loading

$$v_{Ed} = \frac{V_{Ed.red}}{ud} \left[1 + k \frac{M_{Ed}u}{V_{Ed.red}W} \right] \quad \text{Eq. 10.42}$$

Where k is defined in Eq. 10.25 or Eq. 10.30 as appropriate and W is similar to W_l but for perimeter u .

10.4.6 Design of section for punching shear

(1) In bridges, punching should be avoided by providing adequate concrete thickness with sufficient reinforcement for resisting bending and shear, which should also be capable of resisting the worst local punching shear stresses.

(2) The design procedure for punching shear is based on checks at the face of the column and at the basic control perimeter u_0 . The following design shear stresses (MPa) along the control sections, are defined:

$v_{Rd.c}$ is the design value of the punching shear resistance of a slab without punching shear reinforcement along the control section considered i.e. between $2d$ and face of column or loaded area.

$v_{Rd.max}$ is the design value of the maximum punching shear resistance along the control section considered i.e. at the face of column or loaded area.

Where

$$v_{Rd.max} = \frac{1}{2} \cdot v \cdot f_{cd} \quad \text{Eq. 10.43}$$

Where v is given in Eq. 10.6

(3) The following checks should be carried out:

(a) At the column perimeter or the perimeter of the loaded area, the maximum punching shear stress should not be exceeded:

$$v_{Ed} < v_{Rd.max} \quad \text{Eq. 10.44}$$

Where v_{Ed} is given by Eq. 10.24 with $u_i = u_0$

where u_0

- for an inner column = length of column, periphery in mm,
- for edge column = $c_2 + 3d \leq c_2 + 2c_1$ (mm)
- for corner column = $3d \leq c_1 + c_2$ (mm)

(b) Punching shear reinforcement is not necessary if at control section.

$$v_{Ed} < v_{Rd.c} \quad \text{Eq. 10.45}$$

10.5 Torsion

10.5.1 General

- (1) Torsional resistance in concrete elements, in which its longitudinal fibres are free to deform in longitudinal direction, is categorized into equilibrium torsion and compatibility torsion. Where the longitudinal fibres are restrained by external element, warping torsion results. For example, when longitudinal restraint to the deformation of external walls of hollow sections or surfaces of solid sections exists, warping torsion results.
- (2) Equilibrium torsion is that which is essential to keep the element in equilibrium. Such elements shall be designed to cater for full torsional resistance in the ultimate limit state [Fig. 10.14(a)].

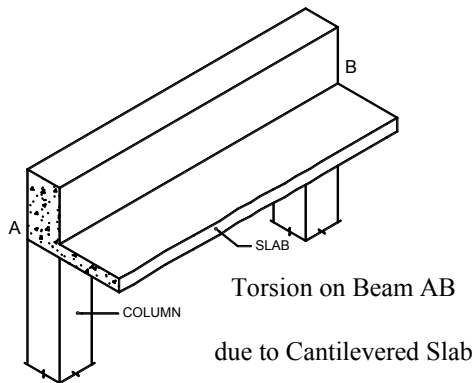

Fig. 10.14(a) Example of equilibrium

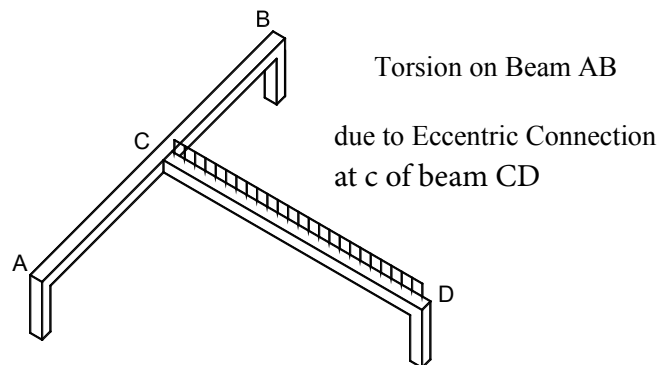

Fig. 10.14(b) Examples of Compatibility Torsion

- (3) If torsional resistance is not essential for stability or static equilibrium of the element, but arises out of compatibility of displacement/ rotations of connected element, it is termed as compatibility torsion. It will not be necessary to consider torsion at ultimate limit state [Fig. 10.14(b)].

Such elements will be subjected to torsional deformations in service leading to cracking and deflection.

To limit the crack width and deformations in the limit state of serviceability, checks as given in Clause 12.3.5 shall be performed. Suitable reinforcement as per detailing Sections shall be provided

- (4) The torsional resistance of a closed section may be calculated on the basis of a thin-walled closed section, in which equilibrium is satisfied by a closed shear flow. Solid sections may be modelled by equivalent thin-walled sections.

Complex shapes, such as T-sections, may be divided into a series of sub-sections, each of which is modelled as equivalent thin walled hollow section. The total torsional resistance is taken as sum of the individual sub-sections.

- (5) The distribution of the acting torsional moments over the sub sections should be in proportion to their uncracked torsional stiffnesses. For hollow sections such as box sections, the equivalent wall thickness should not exceed the actual wall thickness.

- (6) Each sub-section may be designed separately. For conversion of solid sub-section to equivalent hollow section procedure given in **Fig. 10.15** defining the effective thickness of wall $t_{ef,i}$ may be followed.
- (7) In the analysis, torsional stiffness may be calculated on the following basis:
 - (a) In case of equilibrium torsion, the stiffness should be based on uncracked sectional resistance, i.e. gross-section.
 - (b) In case of compatibility torsion, the torsional stiffness may be calculated on the basis of cracked section.

Torsional stiffness of cracked section may be assumed as 25 percent of that of the uncracked section (Refer Clause 7.4).

10.5.2 Design procedures

10.5.2.1 Hollow section and equivalent closed thin wall section

- (1) The shear stress in a wall of a section subject to a pure torsional moment may be calculated from:

$$\tau_{t,i} = \frac{T_{ED}}{2A_k t_{ef,i}} \tag{Eq. 10.46}$$

The design torsional shear force $V_{Ed,i}$ in a wall ‘i’ due to torsion is given by $V_{Ed,i} = \tau_{t,i} t_{ef,i} z_i$ where T_{Ed} is the applied design torsion (see **Fig. 10.15**)

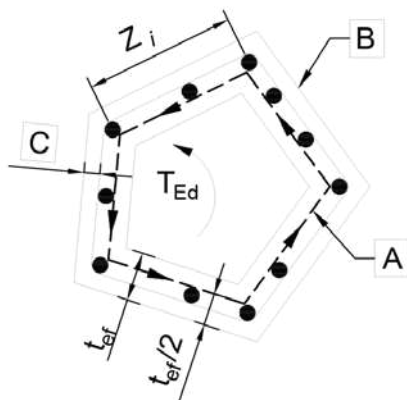

- A - CENTRE LINE
- B - OUTER EDGE OF EFFECTIVE COVER
- C - COVER

- A_k is the area enclosed by the centrelines of the connecting walls, including inner hollow areas.
- $\tau_{t,i}$ is the torsional shear stress in wall i
- $t_{ef,i}$ is the effective wall thickness. It may be taken as A/u , but should not be taken as less than twice the distance between edge and centre of the longitudinal reinforcement. For hollow sections the real thickness is an upper limit.
- A Is the total area of the cross-section within the outer perimeter, including inner hollow areas.
- u is the outer perimeter of the cross-section
- z_i is the side length of wall i defined by the distance between the inter-section points with the adjacent walls.

Fig. 10.15 Notations and Definitions used in Section 10.5.2.1

- (2) For resisting torsion, reinforcement has to be provided both in the longitudinal and transverse direction.
- (3) The shear due to torsion and that due to flexure in both hollow and solid members may be superimposed, where the model of converting solid section to an equivalent closed section

is used. The design of reinforcement is based on truss model. The strut inclination as taken for truss analogy for shear shall be the same for the elements considered to resist torsion. The design reinforcement for the combined shear and torsion, may be considered as per Clauses 10.3.3.2 and 10.3.3.3.

- (4) The maximum resistance of a member subjected to torsion and shear is limited by the capacity of the concrete struts. In order not to exceed this resistance the following condition should be satisfied:

$$T_{Ed} / T_{Rd,max} + V_{NS} / V_{Rd,max} < 1.0 \quad \text{Eq. 10.47}$$

where

T_{Ed} is the design torsional moment

V_{NS} effective shear at design section

$T_{Rd,max}$ is the design torsional resistance moment according to

$$T_{Rd,max} = 2v\alpha_{cw}f_{cd}A_kt_{ef,i} \sin \theta \cos \theta \quad \text{Eq. 10.48}$$

where v is a strength reduction factor for concrete cracked in shear as is referred in Eq. 10.6 and α_{cw} is as given in Notations.

$V_{Rd,max}$ is the maximum design shear resistance according to Clause 10.3.3.2 and 10.3.3.3. In solid cross-sections the full width of the web may be used to determine $V_{Rd,max}$.

- (5) The required cross-sectional area of the longitudinal reinforcement for resisting torsion (ΣA_{sl}) may be calculated from the equation mentioned below:

$$\frac{\Sigma A_{sl}f_{yd}}{u_k} = \frac{T_{Ed}}{2A_k} \cot \theta \quad \text{Eq. 10.49}$$

where

u_k is the perimeter of the area A_k

f_{yd} is the design yield stress of the longitudinal reinforcement A_{sl}

θ is the angle of compression struts

In compressive chords, the longitudinal reinforcement may be reduced in proportion to the available compressive force. In tensile chords the longitudinal reinforcement for torsion should be added to the other reinforcement. The longitudinal reinforcement should generally be distributed over the length, z_i (**Fig. 10.15**).

10.5.2.2 *Warping torsion*

- (1) For closed thin-walled sections and solid sections, warping torsion may normally be ignored unless the longitudinal elongation of the walls/surfaces of the section is restrained by other members.
- (2) In open thin walled members it is necessary to consider warping torsion. For very slender cross-sections the calculation should be carried out on the basis of a beam grid model and for other cases on the basis of a truss model. In all cases the design should be carried out according to the design rules for bending and longitudinal normal force, and for shear.

SECTION 11**ULTIMATE LIMIT STATE OF INDUCED DEFORMATION****11.1 General**

- (1) This Section deals with structures and structural members whose load deformation behaviour and ultimate capacity are significantly affected by second order effects. Second order effects are defined as the additional effects of actions caused by structural deformations. Second order effects can be global, involving structure as a whole, and/or local, involving some of its members, such as columns, walls, compression flanges of beams etc.
- (2) Classical buckling defined as sudden failure due to instability of perfectly axially loaded members without horizontal load does not usually occur in practical reinforced/prestressed concrete members. However, long slender members at ultimate load exhibit large and disproportionate increase of deflections due to combined effect of geometric non-linearity (P- Δ effect) and non-linear structural response due to material non-linearity, progressive cracking and local plasticity. This reduces the ultimate load carrying capacity as compared to the short members of identical cross-section and steel ratio. Therefore, long members should be designed to have higher moment resisting capacity as compared to short members of identical sectional details.
- (3) Second order linear elastic method of analysis shall be used for calculating second order effects. Equilibrium and resistance shall be verified in the deformed state for the most unfavourable combination of actions at ultimate limit state, taking into account uncertainties in geometry and position of axial loads as additional first order effects.
- (4) The distinction between treatment of long column and short column for purpose of this Section 11 is based on 10 percent criteria given in (5) below.
Structural behaviour shall be considered in all directions in which significant second order effects can occur. Biaxial bending shall be taken into account when necessary.
- (5) Second order effects may be ignored if they are less than 10 percent of the corresponding first order effects, calculated on the basis of (3) above.
- (6) In place of method described in (4) & (5) above, simplified criteria for identifying short and long members are given for isolated members of uniform cross-section in Clause 11.2.
- (7) For piers with variable sections and those acting as long composite system together with piles which are not laterally supported below pile caps, (as in case of piles in river portion between the pile cap and scour depth), full height of the substructure shall be analysed using method described in (3). For piles fully embedded in soil, the piers alone can be separately analysed for slenderness effects.
- (8) Compression members that can be isolated from rest of the bridge, whose boundary conditions can be represented by an effective length applied to the member, are defined as isolated members for the purpose of second order analysis.
- (9) Second order analysis shall be carried out under Ultimate Limit State only.

- (10) Braced and Unbraced members:
- (a) Braced members: Members that are held in position at both ends and which may or may not have restraining rotational stiffness at ends.
 - (b) Unbraced members: Members where one end of the member can translate with respect to other end and which have restraining rotational stiffness at one or both ends.

11.2 Simplified Criteria for Second Order Effects

11.2.1 Slenderness criteria for isolated members (columns) of uniform cross-section

(1) Slenderness Ratio

The slenderness ratio λ is defined as l_e / i , where i is the radius of gyration of the uncracked concrete section. The effective length l_e is the length of a pin-ended column with constant axial force having the same cross-section and same buckling load as the actual member.

- (2) Second order effects may be ignored if the slenderness ratio λ based on l_e as per Clause 11.2.2 is less than a certain value λ_{lim} as per Eq.11.1.

$$\lambda_{lim} = 20.A.B.C/\sqrt{n} \quad \text{Eq.11.1}$$

Where

$$A = 1/(1+0.2\phi_{ef})$$

ϕ_{ef} is effective creep ratio.

$$\phi_{ef} = \phi(\infty, t_0) \frac{M_{0Eqp}}{M_{0Ed}}$$

M_{0Eqp} = First order B.M. in quasi-permanent load combination in SLS.

M_{0Ed} = First order B.M. in design load combination in U.L.S.

$$B = \sqrt{1+2\omega}$$

$$C = 1.7 - r_m$$

$\omega = A_s f_{yd} / (A_c f_{cd})$ mechanical reinforcement ratio.

A_s = is the total area of longitudinal reinforcement.

$n = N_{Ed} / (A_c f_{cd})$ relative normal force

$r_m = M_{01} / M_{02}$ moment ratio

M_{01} , M_{02} are the first order end moments at two ends of member as calculated from the analysis of structure, where $|M_{02}| \geq |M_{01}|$.

If the end moments M_{01} & M_{02} give tension on the same side, r_m should be taken positive (i.e. $C \leq 1.7$), otherwise negative (i.e. $C > 1.7$).

In the following cases, r_m should be taken as 1.0 (i.e. $C=0.7$):

- For unbraced members in general.
- For braced members in which the first order moments arise predominantly from imperfections or transverse loading.

Note: For initial dimensioning of member, simplified values of $A=0.7$, $B=1.1$, $C=0.7$ may be used.

- (3) In case of biaxial bending, the slenderness criterion may be checked separately for each direction. Depending on the outcome of this check, second order effects (a) may be ignored in both directions, (b) should be taken into account in one direction, or (c) should be taken into account in both directions.

11.2.2 Effective length (height) of columns and piers

- (1) For compression members in regular frames, the effective length l_e is determined in the following way:

Braced Members:

$$l_e = 0.5l_o \sqrt{\left(1 + \frac{k_1}{(0.45 + k_1)}\right) \times \left(1 + \frac{k_2}{(0.45 + k_2)}\right)} \quad \text{Eq. 11.2}$$

Unbraced Members:

$$l_e = l_o \times \max \left\{ \sqrt{1 + 10 \left(\frac{k_1 k_2}{k_1 + k_2} \right)}; \left(1 + \frac{k_1}{1 + k_1}\right) \times \left(1 + \frac{k_2}{1 + k_2}\right) \right\} \quad \text{Eq. 11.3}$$

where

k_1, k_2 are the relative flexibilities of rotational restraints at ends 1 and 2 respectively.

$$k = \left(\frac{\theta}{M} \right) \left(\frac{EI}{l_o} \right)$$

θ/M = is the rotation of restraining members at a joint for unit bending moment ($M=1$ unit)

EI = is the bending stiffness of compression member

l_o = is the clear height of compression member between end restraints.

Notes:

- (i) In the definition of effective lengths, the stiffness of restraining members should include the effect of cracking, unless they can be shown to be uncracked in ULS.
- (ii) $k=0$ is the theoretical limit for rigid rotational restraint, and $k=\infty$ represents the limit for no restraint at all. Since fully rigid restraint is rare in practice, a minimum value of 0.1 is recommended for k_1 and k_2 , if they are considered as fully rigid.
- (2) Alternatively, for piers/columns the effective length (height) l_e in a given plane of buckling may be obtained from **Table 11.1** where l_o is the clear height between end restraints. The values are based on the following assumptions:

- (a) rotational restraint is at least $\frac{4EI}{l_o}$ for cases 2 to 6 and $\frac{8EI}{l_o}$ for case 7, where EI is the flexural rigidity of the column cross section.
- (b) lateral and flexural rigidities of elastomeric bearings are zero.

Where more accurate evaluation of the effective length is required or where end restraint values are less than those specified in (a), the effective length should be derived using Eq. 11.2 or Eq. 11.3 whichever is applicable.

Table 11.1 Effective Length, l_e for Columns / Piers

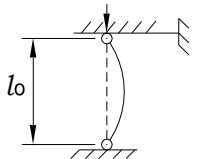
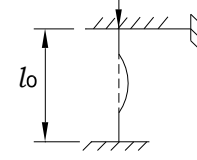
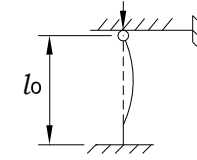
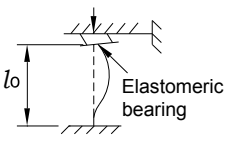
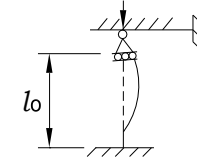
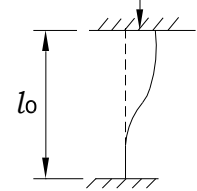
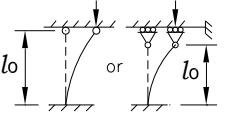
Case	Idealised column and buckling mode	Restraints in Plane of Buckling			Effective Length, l_e
		Location	Position	Rotation	
1.		Top	Full	None	1.0 l_o
		Bottom	Full	None	
2.		Top	Full	Full *	0.70 l_o
		Bottom	Full	Full	
3.		Top	Full	None	0.85 l_o
		Bottom	Full	Full *	
4.		Top	None*	None*	1.3 l_o
		Bottom	Full	Full*	
5.		Top	None	None	1.4 l_o
		Bottom	Full	Full*	
6.		Top	None	Full*	1.5 l_o
		Bottom	Full	Full*	
7.		Top	None	None	2.3 l_o
		Bottom	Full	Full*	

Notes:

1. Positional restraints are given for directions at right angles to the member.
2. Class 1 to 5 shows superstructure held in position which means the deck is held in position at some location other than the pier under consideration (say typically either at another pier or at the abutment.)
3. In case of any floating deck on elastomeric bearings (simply supported or continuous), Case 7 will be applicable.
4. For a continuous deck fixed at any pier/abutment Case 7 applies for the design of fixed pier/abutment. For design of other piers in the longitudinal direction, Case 4 applies for piers with elastomeric bearings and Case 5 applies for piers with free metallic bearings.

11.3 Method of Analysis for Obtaining the Second Order Effects**11.3.1 General**

The methods of analysis include two simplified methods and one general method based on non linear analysis.

- (1) The simplified methods are.
 - (a) Method based on nominal curvature.
 - (b) Method based on nominal stiffness.
- (2) For isolated member method based on nominal curvature is applicable.
- (3) For a group of compression members, as in a framed structure or where they are connected integrally to the same superstructure or a group of piles connected through a pile cap, which cannot be isolated as they collectively resist the side sway of the structure bringing unequal axial loads on the compression members, only the method based on nominal stiffness as per clause 11.3.3.2 is applicable.
- (4) General method based on non-linear analysis.

Non linear analysis may be used for all members with any boundary conditions

- a) In case of members having varying sections and different types of loading such as permanent and quasi-permanent loads leading to creep effects and short term loads such as live loads, generalized methods of non-linear analysis taking into account the geometric non-linearity of structure and or material non linearity need to be used.
- b) Stress-strain relationships for concrete given in Annexure (A2.7) and for steel given in Section 6 (Fig. 6.2 and 6.4) may be used. With stress-strain diagrams based on design value, a design value of the ultimate load is obtained directly from the analysis. In equation Eq.A2-28 and in the calculation of k-value, f_{cm} is then substituted by the design compressive strength f_{cd} and E_{cm} is substituted by: $E_{cd} = \frac{E_{cm}}{\gamma_{cE}}$, where γ_{cE} is taken as 1.2.
- c) In the absence of more refined models, creep may be taken into account by modifying all strain values in the concrete stress-strain diagram using effective E value as per Clause 6.4.2.5.(4) (iii)

11.3.2 Method based on nominal curvature

11.3.2.1 General

This method is primarily suitable for isolated members with constant normal force and a defined effective length l_e . The method gives a nominal second order moment based on a deflection, which in turn is based on the effective length and an estimated maximum curvature.

11.3.2.2 Design bending moments

(1) The design moment is:

$$M_{Ed} = M_{0Ed} + M_2 \quad \text{Eq.11.4}$$

Where

M_{0Ed} is the first order moment, including the effect of imperfections, M_2 is the nominal second order moment, defined in (3)

The maximum value of M_{Ed} is given by the distributions of M_{0Ed} and M_2 ; the latter may be taken as parabolic or sinusoidal over the effective length.

For statically indeterminate members, M_{0Ed} is determined for the actual boundary conditions, whereas M_2 will depend on boundary conditions via the effective length.

The effect of imperfection may be represented by an eccentricity in mm

$$e = 15 + \frac{l_o}{800}$$

Limited to 50 mm.

l_o is the height of pier in mm.

(2) Differing first order end moments M_{01} and M_{02} may be replaced by an equivalent first order end moment M_{0e} :

$$M_{0e} = 0.6 M_{02} + 0.4 M_{01} \geq 0.4 M_{02} \quad \text{Eq. 11.5}$$

M_{01} and M_{02} should have the same sign if they give tension on the same side, otherwise opposite signs. Furthermore, $|M_{02}| \geq |M_{01}|$.

Eq. 11.5 is applicable only to the braced member and also when no transverse load is applied within the height of the member. Further the first order moment due to imperfections shall be added to the equivalent first order moment to get total first order moment in the middle of the member.

$$M_{0Ed} = M_{0e} + \text{moment due to imperfections}$$

(3) The nominal second order moment M_2 in Eq.11.4 is

$$M_2 = N_{Ed} \cdot e_2 \quad \text{Eq. 11.6}$$

where

N_{Ed} is the design value of axial force

$$e_2 \text{ is the deflection} = \frac{1}{r} \cdot \frac{l_e^2}{c}$$

$1/r$ is the curvature, see Clause 11.3.2.3

l_e is the effective length, see Clause 11.2.2

c is a factor depending on the curvature distribution.

- (4) For constant cross-section, $c \approx 10$ ($\approx \pi^2$) is normally used. If the first order moment is constant, a lower value should be considered (8 is a lower limit, corresponding to constant total moment).

Note: The value π^2 corresponds to a sinusoidal curvature distribution. The value for constant curvature is 8. Note that c depends on the distribution of the total curvature.

11.3.2.3 Curvature

- (1) The curvature of any member may be calculated by using

$$\frac{1}{r} = k_r k_\phi \frac{1}{r_0}$$

Eq.11.7

$$\frac{1}{r_0} = \frac{\varepsilon_c + \varepsilon_y}{d}$$

For simplification it can be assumed that the strain in extreme compression fiber ε_c reaches failure strain and can be taken as ε_{cu2} and in the tension steel strain ε_y reaches the yield strain

ε_{yd}

Where

$$\varepsilon_{yd} = \frac{f_{yd}}{E_s}$$

d is the effective depth in the plane of bending

k_r is a correction factor depending upon axial load as given in (3)

k_ϕ is a factor for taking account of creep as given in (4).

- (2) For members with constant symmetrical cross section (including reinforcement) having reinforcement on both faces which reach the yield strains and are separated by lever arm, $z = 0.9d$, the curvature is given by

$$\frac{1}{r_0} = \frac{\varepsilon_{yd}}{0.45d}$$

ε_{yd} and d as defined earlier.

If all reinforcement is not concentrated on opposite sides, but part of it is distributed parallel to the plane of bending, d is defined as:

$$d = \left(\frac{h}{2}\right) + i_s \quad \text{Eq. 11.8}$$

Where i_s is the radius gyration of the total reinforcement area.

- (3) As a simplification k_r in equation (11.7) may be taken as 1.0 on the conservative side. Alternatively k_r can be calculated as shown below:

$$k_r = (n_u - n) / (n_u - n_{bal}) \leq 1 \quad \text{Eq. 11.9}$$

Where

$$n = \frac{N_{Ed}}{A_c f_{cd}}$$

N_{ED} = design value of axial force

$$n_u = 1 + \omega$$

n_{bal} is the value of n calculated using the balanced axial force corresponding to the maximum moment of resistance of section which shall be obtained by constructing the Axial Load-Moment interaction diagram.

For symmetrically reinforced rectangular sections n_{bal} can be taken as 0.4.

$$\omega = \frac{A_s f_{yd}}{A_c f_{cd}}$$

Where

A_s = total area of reinforcement, and,

A_c = area of concrete cross - section.

- (4) The effect of creep should be taken into account by the following factor:

$$K_\varphi = 1 + \beta \varphi_{ef} \geq 1 \quad \text{Eq. 11.10}$$

Where

φ_{ef} is the effective creep ratio (defined in 11.2.1)

$$\beta = 0.35 + \frac{f_{ck}}{200} - \frac{\lambda}{150} \quad \text{Eq. 11.11}$$

Where

λ = is the slenderness ratio.

11.3.2.4 Design Bending moment for braced and un-braced member

The design bending moment shall be evaluated as given below:

- (a) For braced member:
Equivalent first order moment including, moment due to imperfections in the middle of the member and moment due to second order effect shall be added to arrive at the design bending moment at middle of the member.
Numerically initial larger first order end moment assuming no moments due to imperfections and second order effect develop will be the design moment at this end.
- (b) For un-braced member:
First order end moment including, moment due to imperfections and moment due to second order effects shall be added to arrive at the design bending moment at the ends.
- (c) For cantilever member:
First order moment including, moment due to imperfections and moment due to second order effect shall be added to get the design moment at different sections.

11.3.3 Method based on nominal stiffness

11.3.3.1 Nominal flexural stiffness

- (1) In second order analysis based on stiffness, nominal values of the flexural stiffness shall be used.
- (2) In the nominal stiffness method, the flexural rigidity of slender compression members with any cross section can be estimated using the following expression.

$$EI = K_c E_{cd} I_c + K_s E_s I_s \quad \text{Eq. 11.12}$$

Where

E_{cd} is the design value of the modulus of elasticity of concrete, see clause 11.3.1 (4) (b)

I_c is the moment of inertia of concrete cross sections

E_s is the design value of the modulus of elasticity of reinforcement.

I_s is the second moment of area of reinforcement, about the centre of area of the concrete.

K_c is a factor for effects of cracking, creep etc, Refer (3) or (4) below.

K_s is a factor for contribution of reinforcement, Refer (3) or (4) below.

- (3) The following factors may be used in Expression, provided $P \geq 0.002$;

$$K_s = I$$

$$K_c = k_1 k_2 / (I + \phi_{cr})$$

Where

ρ is the geometric reinforcement ratio, A_s/A_c

- A_s is the total area of reinforcement
 A_c is the area of concrete section
 ϕ_{ef} is the effective creep ratio, see clause 11.2.1 (2)
 k_1 is a factor which depends on concrete strength class,
 $k_1 = \sqrt{f_{ck} / 25} \text{ (MPa)}$
 k_2 is a factor which depends on axial force and slenderness,
 $k_2 = n \frac{\lambda}{170} \leq 0.20$

where

- n is the relative axial force, $N_{Ed} / (A_c f_{cd})$
 λ is the slenderness ratio, see clause 11.2.1 (1)
 If the slenderness ratio λ is not defined, K_2 may be taken as
 $k_2 = 0.30n \leq 0.20$

- (4) As a simplified alternative, provided $\rho \geq 0.01$, the following factors may be used in Expression (given in (1)).

$$K_s = 0 \quad K_c = 0.3 / (1 + 0.5 \phi_{ef}) \quad \text{Eq. 11.13}$$

Note The simplified alternative may be suitable as a preliminary step, followed by a more accurate calculation according to (3)

- (5) For determining the effective lengths of compression members in regular frames the effect of cracking of the adjacent members on the rotational restraint provided by them shall be taken into account in accordance with equation 11.2 and 11.3.

11.3.3.2 Moment Magnification

The total design moment including, second order moment can be obtained by magnifying the first order bending moments resulting from a linear analysis and moment due to imperfections where they are additive in nature.

For slender compression members occurring in a group having varying axial load in members as explained in clause 11.3.1 (3) the design bending moment shall be taken as:

$$M_{ED} = \frac{M_{oED}}{1 - (\Sigma N_{ED} / \Sigma N_B)} \quad \text{Eq. 11.14}$$

M_{ED} = Design moment

M_{oED} = First order moment including moment due to imperfection. where applicable

ΣN_{ED} is the total design axial load on the group.

ΣN_B is the total buckling load of all the compression members in the group based on nominal stiffness.

N_B is the buckling load based on the formula $\pi^2 EI / l_e^2$ where l_e is the effective length.

11.3.3.3 *Design bending moment*

The design bending moment shall be evaluated as given below:

- (a) For Braced members
 - (1) Equivalent first order moment as defined in Eq 11.5 and the moment due to imperfections in the middle of the member shall be added and magnified in accordance with clause 11.3.3.2
 - (2) Numerically larger first order initial end moment assuming no second order effects and imperfections.
- (b) For un-braced members:
First order end moments including moments due to imperfections shall be magnified. as per clause 11.3.3.2
- (c) For cantilever members:
The first order moment and the moment due to imperfections shall be added and magnified throughout its height as per clause 11.3.3.2

11.3.4 *Bi-axial Bending*

- (1) The general method described in Clause 11.3.1 may also be used for biaxial bending. Special care should be taken to identify the section along the member with the critical combination of moments.
- (2) For details of the use of simplified methods for biaxial moment taking second order deformation into account, Clause 8.3.2 may be referred.

11.4 **Lateral Instability of Slender Beam**

11.4.1 *General*

- (1) Lateral instability of slender beams shall be taken into account where necessary viz. for precast beams during transport and erection and for beams without sufficient lateral bracing in the construction stage and in the completed structure. Geometric imperfections shall also be taken into account.
- (2) A lateral deflection of $l / 300$ should be assumed as a geometric imperfection in the verification of beams in unbraced conditions, with l = total length of beam. In finished structures, bracing from connected members may be taken into account.
- (3) Second order effects in connection with lateral instability may be ignored if the following conditions are fulfilled:

- in persistent situations: $\frac{l_{ot}}{b} \leq \frac{50}{(h/b)^{1/3}}$ and $h/b \leq 2.5$ **Eq. 11.15**

- in transient situations: $\frac{l_{ot}}{b} \leq \frac{70}{(h/b)^{1/3}}$ and $h/b \leq 3.5$ **Eq. 11.16**

where

l_{ot} is the distance between torsional restraints

h is the total depth of beam in central part of l_{ot}

b is the effective width of compression flange

- (4) Torsion associated with lateral instability should be taken into account in the design of supporting structures.

11.4.2 *Slenderness limits for beams*

To ensure lateral stability, a simply supported or continuous beam should be so proportioned that the clear distance between lateral restraints does not exceed $60 b_e$ or, $250 b^2/h$ whichever is the lesser,

where

h is the effective depth to tension reinforcement.

b is the breadth of the compression face of the beam midway between restraints.

For cantilevers with lateral restraint provided only at the support, the clear distance from the free end of the cantilever to face of the support should not exceed $25b$ or $100b^2/h$, whichever is the lesser.

SECTION 12

SERVICEABILITY LIMIT STATE

12.1 General

(1) In order to verify that the structure and structural elements perform adequately during service life. The serviceability limit states shall have to be satisfied. The serviceability limit states are:-

- Stress level
- Crack width
- Deflection

Other limit states such as vibration may be of importance in a particular structure, but are not covered in this Section.

(2) In calculation of stresses and deflection, the cross-section shall be assumed as uncracked provided tensile stress in concrete does not exceed f_{ctm} or $f_{ctm,fl}$ and calculation of minimum tension reinforcement is also based on the same value of f_{ctm} or $f_{ctm,fl}$. Where tensile stresses exceed f_{ctm} or $f_{ctm,fl}$ cross-section shall be considered as cracked.

12.2 Stress Limitation

12.2.1 Allowable compressive stress in concrete

(1) Maximum compressive stress in concrete under rare combinations of loads shall be limited to $0.48 f_{ck}$, in order to keep the longitudinal cracks, micro cracks or creep within acceptable limits.

(2) Where compressive stress in concrete under quasi-permanent loads is within $0.36 f_{cm}(t_0)$, linear creep may be assumed. In case compressive stress exceeds $0.36 f_{cm}(t_0)$, non-linear creep shall be considered. For stress level in the range of $0.36 f_{cm}(t_0) < \sigma_c \leq 0.48 f_{cm}(t_0)$, non-linear creep may be taken into account using the following equation:

$$\varphi_{\sigma}(t, t_0) = \varphi(t, t_0) \exp [1.5 (k_{\sigma} - 0.36)] \text{ for } 0.36 < k_{\sigma} \leq 0.48$$

$\varphi_{\sigma}(t, t_0)$ is the non-linear creep coefficient.

$\varphi(t, t_0)$ is the linear creep coefficient.

$$k_{\sigma} = \frac{\sigma_c}{f_{cm}(t_0)} \text{ is the strength ratio.}$$

12.2.2 Allowable tensile stress in steel

In order to avoid inelastic strain and undesirable cracking/deformation of structure, maximum tensile stress (taking due account of long term creep of concrete) in the reinforcement shall be limited to $0.8 f_{yk}$ under rare combination of loads. For prestressing steel, in order to avoid inelastic strain, limits prescribed in Clause 7.9.2 shall be adhered to.

12.3 Limit State of Cracking

12.3.1 General

Cracking takes place in tensile regions of concrete structures due to load effects, such as bending, shear, torsion and direct tension. Cracks may also be caused due to internal deformations such as shrinkage and temperature effects. The intent of the following provisions is to ensure, with acceptable probability, that the cracks will not impair the proper functioning or durability of the structure or cause its appearance to be unacceptable. Cracks due to other effects such as expansive chemical reactions need to be controlled by measures given under Section 14.

12.3.2 Limiting crack width

- (1) Due to the random nature of the cracking phenomenon, actual crack width cannot be predicted. However, a reasonable estimation of crack width can be made using the mathematical model given in Clause 12.3.4. The crack width, so calculated, shall be restricted to the values given in **Table 12.1** for various conditions of exposure. The decompression limit check requires that no tensile stresses occur within 100mm of the surface of duct for bonded prestressing tendons.

This provision of 100 mm is not a cover requirement for prestressing duct, for which provision has been made in clause 14.3.2.1. In case the duct is closer than 100 mm to concrete surface the concrete within the cover portion shall be in compression.

Table 12.1 Recommended Values of W_{max}

Condition of Exposure As per Clause 14.3.1	Reinforced members and prestressed members with un-bonded tendons	Prestressed members with bonded tendons
	Quasi-permanent load combination (mm)	Frequent load combination (mm)
Moderate	0.3 ⁽²⁾	0.2
Severe	0.3	0.2 ⁽³⁾
Very Severe	0.3	0.2 and decompression ⁽⁴⁾
Extreme	0.2	0.2 and decompression ⁽⁴⁾

- (1) The condition of exposure considered applies to the most severe exposure the surface will be subjected to in service.
- (2) For moderate exposure class, crack width has no influence on durability and this limit is set to guarantee acceptable appearance.
- (3) For these conditions of exposure, in addition, decompression should be checked under the quasi-permanent combination of loads that include DL+ SIDL + Prestress including secondary effect + settlement + temperature effects.
- (4) 0.2 applies to the parts of the member that do not have to be checked for decompression.
- (2) For the crack width checks under combinations which include temperature distribution, the resulting member forces should be calculated using gross section concrete properties. The effect of self-equilibrating thermal stresses within a section may be ignored.

- (3) For members with only unbonded tendons, requirements for reinforced concrete elements apply. For members with a combination of bonded and unbonded tendons, requirements for prestressed concrete members with bonded tendons apply.
- (4) Crack width may be calculated according to Clause 12.3.4. Alternatively, limiting maximum bar size or spacing as per Clause 12.3.6 may be deemed to satisfy crack control criteria for reinforced concrete members.

12.3.3 *Minimum reinforcement for crack control*

- (1) A minimum amount of untensioned reinforcement is required to control cracking in areas where tension due to external loadings or external restraints is expected. The amount of such reinforcement may be estimated from equilibrium between the tensile force in concrete just before cracking and tensile force in steel at yielding.
- (2) Minimum area of reinforcement may be calculated as follows. In profiled cross sections like T-beams and box girders, minimum reinforcement should be determined for the individual parts of the section (webs, flanges).

$$A_{s,min} \sigma_s = k_c k f_{ct, eff} A_{ct} \tag{Eq 12.1}$$

where

$A_{s,min}$ is the minimum area of reinforcing steel within the tensile zone

A_{ct} is the area of concrete within tensile zone. The tensile zone is that part of the section which is calculated to be in tension just before formation of the first crack.

In the flanged cross sections such as T-beams and box girders the division into parts should be as indicated in **Fig. 12.1**.

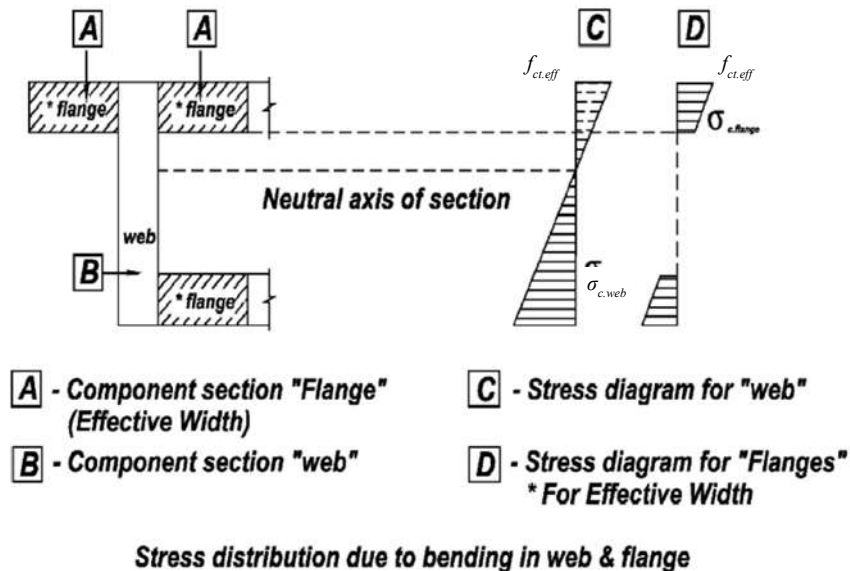

Fig. 12.1 Typical Division of a Flanged Cross-Section for Analysis of Cracking

σ_s is the absolute value of the maximum stress permitted in the reinforcement immediately after formation of the crack. This may be taken as the yield strength of the reinforcement, f_{yk} . A lower value may, however, be needed to satisfy the crack

width limits according to the maximum bar size or the maximum bar spacing [refer Clause 12.3.6 (2)].

$f_{ct,eff}$ is the mean value of the tensile strength of the concrete effective at the time when the cracks may first be expected to occur $f_{ct,eff} = f_{ctm}$ or lower, $f_{ctm}(t)$, if the minimum area of reinforcement is to be calculated for control of cracking earlier than 28 days.

In calculating the minimum reinforcement to cater for shrinkage $f_{ct,eff}$ should be taken as the greater of 2.9 MPa or $f_{ctm}(t)$.

k is the coefficient which allows for the effect of non-uniform self equilibrating stresses, which lead to a reduction of restraint forces

= 1.0 for webs with $h < 300$ mm or flanges with widths less than 300 mm

= 0.65 for webs with $h > 800$ mm or flanges with widths greater than 800 mm.

Intermediate values may be interpolated.

k_c is a coefficient which takes account of the stress distribution within the section just prior to cracking and of the change of the lever arm:

For pure tension $k_c = 1.0$

For bending or bending combined with axial forces:

- For rectangular sections and webs of box sections and T-sections:

$$k_c = 0.4 \left[1 - \frac{\sigma_c}{k_1 (h/h^*) f_{ct,eff}} \right] \leq 1 \quad \text{Eq. 12.2}$$

- For flanges of box sections and T-sections:

$$k_c = 0.9 \frac{F_{cr}}{A_{ct} f_{ct,eff}} \geq 0.5 \quad \text{Eq. 12.3}$$

Where

σ_c is the mean stress of the concrete acting on the part of the section under consideration:

$$\sigma_c = \frac{N_{Ed}}{bh} \quad \text{Eq. 12.4}$$

N_{Ed} is the axial force at the serviceability limit state acting on the part of the cross-section under consideration (compressive force positive).

N_{Ed} should be determined under the relevant combination of actions considering the characteristic value of prestress and axial forces.

k_1 is a coefficient considering the effects of axial forces on the stress distribution:

$k_1 = 1.5$ if N_{Ed} is a compressive force

$k_1 = \frac{2h^*}{3h}$ if N_{Ed} is a tensile force

$h^* = h$ for $h < 1.0$ m

$h^* = 1.0$ m for $h \geq 1.0$ m

F_{cr} is the absolute value of the tensile force within the flange just prior to cracking due to the cracking moment calculated with $f_{ct,eff}$

- (3) Contribution of prestressing steel towards minimum reinforcement for crack control shall be ignored.
- (4) In prestressed members, no minimum reinforcement is required in sections where the concrete is in compression under the rare combination of loads and the characteristic value of prestress.

However minimum reinforcement for other considerations such as, early thermal and shrinkage cracking, prior to application of prestressing, shall be provided as per Section 16.

12.3.4 Calculation of crack width

- (1) Crack width varies between the reinforcement bars depending upon the spacing of the bars. The crack width, W_k , may be calculated from Eq.12.5.

Due account should also be taken of the effects of restrained thermal and shrinkage effects.

$$W_k = S_{r, max} (\varepsilon_{sm} - \varepsilon_{cm}) \quad \text{Eq 12.5}$$

Where

$s_{r, max}$ is the maximum crack spacing (Refer Eq.12.8, 12.11 or 12.12)

ε_{sm} is the mean strain in the reinforcement under the relevant combination of loads, including the effect of imposed deformations, restrained thermal and shrinkage effects and taking into account the effects of tension stiffening. For prestressed members only the additional tensile strain beyond the state of zero strain of the concrete at the same level is considered

ε_{cm} is mean strain in the concrete between cracks

- (2) $\varepsilon_{sm} - \varepsilon_{cm}$ may be calculated from:

$$\varepsilon_{sm} - \varepsilon_{cm} = \frac{\sigma_{sc} - k_t \frac{f_{ct,eff}}{\rho_{p,eff}} (1 + \alpha_e \rho_{p,eff})}{E_s} \geq 0.6 \frac{\sigma_{sc}}{E_s} \quad \text{Eq. 12.6}$$

Where

σ_{sc} is the stress in the tension reinforcement assuming a cracked section.

α_e is the ratio E_s/E_{cm}

$$\rho_{p,eff} = A_s / A_{c,eff} \quad \text{Eq 12.7}$$

$A_{c,eff}$ For rectangular section it is the effective area of concrete in tension surrounding the reinforcement of depth h_{cef} , where h_{cef} is the lesser of $2.5(h-d)$; $(h-x)/3$; or $h/2$ (refer **Fig. 12.2**)

For circular section a thin slice in the plane of bending through diameter having width equal to spacing of reinforcement bars may be taken and analyzed. $A_{c,eff}$, h_{cef} and $\rho_{p,eff}$ shall be calculated for this slice taking d as the effective depth of reinforcement in this width.

k_t is a factor dependent on the duration of the load which may be taken as 0.5.

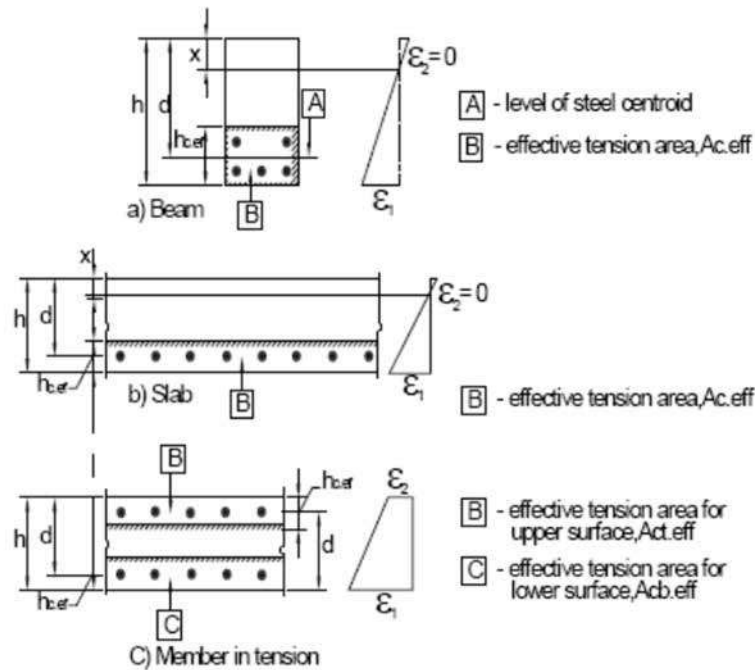

Fig. 12.2 Effective Tension Area (Typical Cases)

- (3) In situations where spacing of bonded reinforcement within the tension zone is reasonably close (i.e. $\leq 5(c + \phi/2)$), the maximum final crack spacing may be calculated from Eq. 12.8.

$$S_{r,max} = 3.4c + \frac{0.425 k_1 k_2 \phi}{\rho_{p,eff}} \quad \text{Eq. 12.8}$$

where

ϕ is the bar diameter. Where bars of different diameters are used in a section, an equivalent diameter, ϕ_{eq} , should be used. For a section with n_1 bars of diameter ϕ_1 and n_2 bars of diameter ϕ_2 , the Eq. 12.9 should be used.

$$\phi_{eq} = \frac{n_1 \phi_1^2 + n_2 \phi_2^2}{n_1 \phi_1 + n_2 \phi_2} \quad \text{Eq. 12.9}$$

c is the clear cover to the longitudinal reinforcement. Wherever the clear cover exceeds 50 mm a value of 50 mm shall be used in the calculation.

k_1 is a coefficient which takes account of the bond properties of the bonded reinforcement:

= 0.8 for deformed bars

= 1.6 for bars with an effectively plain surface

For epoxy coated bars, the above values shall be increased by 25 percent.

k_2 is a coefficient which takes account of the distribution of strain:

= 0.5 for bending

= 1.0 for pure tension

For cases of eccentric tension or local areas, intermediate values of k_2 should be used which may be calculated from Eq. 12.10:

$$k_2 = \frac{(\varepsilon_1 + \varepsilon_2)}{2\varepsilon_1} \quad \text{Eq. 12.10}$$

Where ε_1 is the greater and ε_2 is the lesser tensile strain at the boundaries of the section considered, assessed on the basis of a cracked section.

For the case of deformed bars associated with pure bending

$$S_{r,\max} = \frac{3.4c + 0.17\phi}{\rho_{\rho,\text{eff}}} \quad \text{Eq. 12.11}$$

Where the spacing of the bonded reinforcement exceeds $5(c + \phi/2)$ or where there is no bonded reinforcement within the tension zone, an upper bound limit to the crack width may be found by assuming maximum crack spacing:

$$S_{r,\max} = 1.3(h-x) \quad \text{Eq. 12.12}$$

Where 'h' is the effective depth and 'x' is depth of neutral axis from the compression face.

- (4) Where the angle between the axes of principal stress and the direction of the reinforcement, for members reinforced in two orthogonal directions 'y' & 'z', is significant ($>15^\circ$), then the crack spacing $S_{r,\max}$ may be calculated from the following expression:

$$S_{r,\max} = \frac{1}{\frac{\cos \theta}{S_{r,\max,y}} + \frac{\sin \theta}{S_{r,\max,z}}} \quad \text{Eq. 12.13}$$

Where

θ is the angle between the reinforcement in the y direction and the direction of the principal tensile stress.

$S_{r,\max,y}$ $S_{r,\max,z}$ are the crack spacings calculated in the y and z directions respectively, according to Clause 12.3.4 (3).

Note: Where simplified methods of calculating crack width are used they should be based on the properties given in this Code or substantiated by tests.

12.3.5 Control of shear cracks within webs

Where it is considered necessary to check shear cracking, particularly for prestressed members, the reinforcement required for crack control can be determined as follows:

- (1) The directionally dependent concrete tensile strength f_{ctb} within the webs should be calculated from:

$$f_{ctb} = \left(1 - 0.8 \frac{\sigma_3}{f_{ck}} \right) f_{ctk,0.05} \quad \text{Eq. 12.14}$$

where

f_{ctb} is the concrete tensile strength prior to cracking in a biaxial state of stress in webs.

σ_3 is the larger compressive principal stress, taken as positive.

$$\sigma_3 < 0.6 f_{ck}$$

$f_{ctk,0.05}$ is lower characteristic tensile strength (**Table 6.5**)

- (2) The larger tensile principal stress in the web σ_1 is compared with the corresponding strength f_{ctb} obtained from Eq. 12.14.

If $\sigma_1 < f_{ctb}$, the minimum reinforcement in accordance with Clause 12.3.3 should be provided in the longitudinal direction.

If $\sigma_1 \geq f_{ctb}$, the crack width should be controlled in accordance with Clause 12.3.6 or alternatively calculated and verified in accordance with Clause 12.3.4 taking into account the angle of deviation between the principal stress and reinforcement directions.

12.3.6 Control of cracking without direct calculation

- (1) The rules given in Section 12.3.4 may be presented in tabular form by restricting the bar diameter or spacing as a simplification.
- (2) **Table 12.2** gives maximum bar diameter subjected to different stress levels of steel under relevant combination of load for which crack width is to be controlled. **Table 12.3** gives the maximum spacing of bars in mm for two crack widths for similar condition.
- (3) The values in the tables are based on the following assumptions:
 $c=40\text{mm}$; $f_{ct,eff}=2.8\text{ MPa}$; $h_{cr} = 0.5$; $(h-d) = 0.1h$; $k_1=0.8$; $k_2=0.5$; $k_3=0.5$ and $k=1.0$
- (4) Where the minimum reinforcement given by Clause 12.3.3 is provided, crack widths are unlikely to be excessive if:
- for cracking dominantly caused by restraint, the bar sizes given in **Table 12.2** are not exceeded where the steel stress is the value obtained immediately after cracking (i.e σ_s in Eq. 12.1).
 - for cracks caused mainly by loading, either the provisions of **Table 12.2** or **Table 12.3** shall be complied with. The steel stress should be calculated on the basis of a cracked section under the relevant combination of actions.
- (5) For pre-tensioned concrete, where crack control is mainly provided by tendons with direct bond, **Table 12.2** or **Table 12.3** may be used with a stress equal to the total stress minus prestress.
- (6) For post-tensioned concrete, where crack control is provided mainly by untensioned reinforcement, the tables may be used with the stress in this reinforcement calculated with the effect of prestressing forces included.

Table 12.2 Maximum Bar Diameters ϕ_s for Crack Control

Steel stress [MPa]	Maximum bar size [mm]	
	$W_k = 0.3\text{ mm}$	$W_k = 0.2\text{ mm}$
160	32	25
200	25	16
240	16	12
280	12	-
320	10	-

Table 12.3 Maximum Bar Spacing for Crack Control

Steel stress [MPa]	Maximum bar spacing [mm]	
	$W_k = 0.3$ mm	$W_k = 0.2$ mm
160	300	200
200	250	150
240	200	100
280	150	50
320	100	-

Note: **Table 12.2** and **12.3** are applicable for circular section also.

- (7) It should be noted that there are particular risks of large cracks occurring in locations where there are sudden changes of stress, e.g.
- at changes of section
 - near concentrated loads
 - at positions where bars are curtailed
 - at areas of high bond stress, particularly at the ends of laps

Care should be taken at such locations to minimize the stress changes wherever possible. However, the rules for crack control given above will normally ensure adequate control at these points provided that the rules for detailing reinforcement given in Section 16 are complied with.

12.4 Limit State of Deflection

12.4.1 General

Cable supported bridges are not in the purview of this Code, for which specialist literature may be followed.

- (1) The deflections/deformations of a member or structure shall not be such that it adversely affects its proper functioning or appearance. In some cases, expected deflections may need to be adjusted in the structural geometry by pre-cambering, so as to attain the requisite profile at the time of placing expansion joints and wearing course.
- (2) Appropriate limiting values of deflection taking into account the nature of the structure, bridge deck furniture and functional needs of the bridge, should be established. In the absence of other criteria, the following deflection limits for live load under frequent load combination may be considered.

Vehicular	: Span/800,
Vehicular and pedestrian or pedestrian alone	: Span/1000,
Vehicular on cantilever	: Cantilever Span/300, and
Vehicular & pedestrian and pedestrian only on cantilever arms	: Cantilever Span/375

12.4.2 *Calculation of deflection due to sustained loads*

- (1) The calculation method adopted shall represent the true behaviour of the structure under relevant actions with accuracy appropriate to the objectives of the calculation. In case of cracked members, appropriate value of cracked moment of inertia shall be used. If, actual value of cracked moment of inertia cannot be determined, it may be taken equal to 70 percent of uncracked moment of inertia. For uncracked members such as prestressed concrete members, fully under compression, uncracked moment of inertia may be used.
- (2) For loads with long enough duration to cause creep, the total deformation including creep may be calculated by using an effective modulus of elasticity for concrete according to Eq.12.15

$$E_{c,eff} = \frac{E_{cm}}{1 + \phi(\infty, t_o)}$$

Eq. 12.15

where

 $\phi(\infty, t_o)$ is the creep coefficient relevant for the load and time interval (see Clause 6.4.2.7).

- (3) Shrinkage curvatures may be assessed using Eq 12.16

$$\frac{1}{r_{cs}} = \varepsilon_{cs} \alpha_e \frac{S}{I}$$

Eq. 12.16

Where

 $1/r_{cs}$ is the curvature due to shrinkage ε_{cs} is the free shrinkage strain (refer Clause 6.4.2(6)) S is the first moment of area of the reinforcement about the centroid of the section I is the second moment of area of the section α_e is the effective modular ratio = $E_s / E_{c,eff}$

SECTION 13

PRESTRESSING SYSTEMS

13.1 General

This Section covers requirements of the parts of prestressing systems which are incorporated in the structure. Prestressing systems manufactured by specialist manufacturers shall be compatible with the standard prestressing wires/strands covered in Section 6. The stressing equipment, de-stressing/re-stressing facilities, and grouting arrangements shall be compatible with the tendons.

13.2 Anchorages for Post Tensioning Systems

13.2.1 *Anchorage to be used*

Following types of anchorages normally used in bridges shall meet the minimum requirements given in this Section.

- (1) Anchorages partially or fully embedded in concrete in which the prestressing force is transferred within the body of the prestressed element by combination of bearing, friction and wedge action.
- (2) Externally mounted anchorages which transfer prestressing force of tendons to concrete through a bearing plate which is externally mounted.

13.2.2 *Minimum requirements of anchorage capacity*

- (1) The anchorage device should be capable of holding and transferring force of not less than 95 percent of the actual mean tensile ultimate strength of the tendons it is expected to hold, without failure of any of the parts of the anchorage-tendon assembly.
- (2) The anchorage tendon assembly shall be capable of withstanding not less than two million cycles of fatigue load varying between 60 percent to 65 percent of nominal UTS of tendons it is expected to hold, without suffering more than 5 percent breakage of wires/ strands at the load frequency of not more than 500 cycles per minute.

13.2.3 *Load transfer to concrete element through end block*

The end block is the portion of the concrete element through which the concentrated load applied at anchorages is transmitted to the whole cross section of the element. The concrete and the reinforcement in this region shall be designed to transfer load not less than 110 percent of nominal UTS of tendons it is expected to hold. The crack width shall not exceed 0.25 mm at 80 percent of UTS.

13.2.4 *Acceptance tests for anchorage-tendon assembly*

The anchorage-tendon assemblies shall comply with the following acceptance tests as per FIP “Recommendations for the acceptance of post-tensioning systems” – (June 1993).

- (1) Static load test with tendon-anchorage.
- (2) Dynamic load test with tendon-anchorage assembly.
- (3) Load transfer test.

13.3 Mechanical Couplers

Mechanical couplers of fixed or movable type are devices in which individual lengths of tendons are anchored in two collinear directions to form one continuous tendon. The couplers shall meet the requirements of strength of individual anchorages as specified in Clause 13.2, and be able to transfer full force of tendon from one to another. The anchorage and stressing of second tendon should not disturb the anchorage of the first tendon in case of fixed couplers.

13.4 Sheathing Ducts and Joints

The sheathing ducts shall be either in mild steel as per Clause 13.4.2 or in HDPE as per Clause 13.4.3. They shall be in as long lengths as practicable from handling and transportation considerations without getting damaged. The internal joints of the duct lengths shall be watertight when bent to the minimum radius of bending required in the structure as specified in Clause 13.4.1 (2).

13.4.1 *Common requirements of joints of sheathing*

- (1) The ducts lengths shall be joined by adopting any one or more of the following methods as convenient to suit the individual requirements of the location, subject to satisfactory pressure tests, before adoption.
 - Using corrugated threaded sleeve couplers which can be tightly screwed to the outside of the sheathing ducts.
 - Integrating the two ends by welding using electric roaster machine or mirror machine.
 - Using heat shrink couplers.
- (2) The sheathing ducts and connections should be fully leak-tight against water pressure equivalent to $1.1 \times$ (maximum expected gravity head of grouting material + grouting pressure). The joints should also be leak-tight and pressure resistant for above pressure.
- (3) External tendons shall be housed in either High Density Poly- Ethylene (HDPE) sheaths or metallic steel sheaths (plain or with protective coatings), which have smooth internal surfaces.
- (4) Special precautions are required in the case of joints particularly in precast segmental construction. Leakages as well as interconnections between ducts, should be avoided. Duct spacing should be detailed in such a way that there is sufficient concrete between parallel ducts to prevent interconnections during grouting operations and to comply with relevant IRC codes.

As a general rule, the joints of precast segmental construction are treated with epoxy resin, if internal grouted tendons are used. The epoxy resin seals the joint and prevents grout leaking through and out of the segment joint. However there is a possibility that epoxy may be squeezed into adjacent ducts, when the segments are pressed together, causing blockages. To prevent this, generally a compressible foam seal is provided in the segment joint around the duct, and the excess is scraped out with plastic or rubber scrapers before the epoxy sets. Also the leak tightness of internal prestressing tendons can be improved by the use of rubber rings around the ducts at the joints between segments. Before casting of the segment, steel rings are placed around the ducts, leaving an imprint of half the thickness

of the rubber rings. The rubber rings are placed in this recess, and are compressed when the temporary prestressing is applied.

However, jointing with encapsulation is the preferable option and system suppliers may be having their own method of doing so.

13.4.2 *M.S. sheathing ducts*

- (1) Unless otherwise specified, the material shall be Cold Rolled Cold Annealed (CRCA) Mild Steel intended for mechanical treatment and surface refining but not for quench hardening or tempering.
- (2) The material shall be clean and free from rust and normally of bright metal finish. However, in case of use in aggressive environment galvanised or lead coated mild steel strips shall be adopted.
- (3) The thickness of metal sheathing shall not be less than 0.3 mm, 0.4 mm and 0.5 mm for sheathing ducts having internal diameter upto 50 mm, 75 mm and 90 mm and above respectively. For larger diameter ducts, thickness of sheathing shall be based on recommendations of prestressing system supplier. For some types of M.S. sheathing ducts, refer **Fig 13.1**.
- (4) The metal sheathing shall conform to the requirements specified in **Annexure A5** and a test certificate shall be furnished by the manufacturer. The joints of all sheathing shall be watertight and conform to provisions specified in **Annexure A5**.

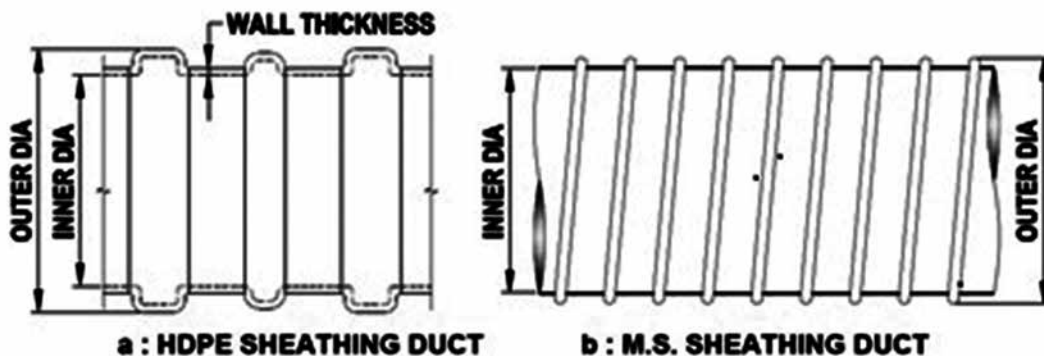

Fig 13.1 Typical Types of Sheathing Ducts

13.4.3 *Corrugated HDPE sheathing ducts*

- (1) The material for the ducts shall be high density polyethylene with more than 2% carbon black to provide resistance to ultraviolet degradation and properties of raw materials shall comply with the provisions of **Annexure A5**.
- (2) The minimum wall thickness of the duct as manufactured shall be 2.0 mm, 2.5 mm, 3 mm, and 4 mm for the ducts of internal diameter 50 mm, 85 mm, 100 mm and 125 mm respectively. Linear interpolation may be done for any intermediate values.
Tolerance for duct diameter is $\pm 1\%$ or ± 1 mm, whichever is greater. Tolerance for wall thickness shall be $-0/+0.5$ mm.
- (3) For internally bonded tendons, the ducts shall be corrugated on both sides. The ducts shall transmit full tendon strength from the tendon to the surrounding concrete over a length not

greater than 40 times duct diameter. For some of the types of corrugated HDPE sheathing ducts, refer **Fig. 13.1**.

- (4) Minimum internal diameter of the HDPE duct shall not be less than 3 times the cross-sectional area of the tendon which can be fitted in the anchorage system used. However, in case of threading of tendons after concreting for spans larger than 30 m, internal diameter of duct shall be 5 mm larger than the requirement stated above, in order to facilitate threading.

13.5 Anchorage Block Design and Detailing

Requirements given in this clause are in addition to those given in Clause 16.14 on detailing. The overall design of the end block shall take into account the stress distribution based on elastic distribution of forces in uncracked section and suitable reinforcement shall be provided to take up the tensions respecting the crack width limitations. The bursting forces in the end blocks, should be assessed on the basis of the ultimate tensile strength.

13.5.1 Bursting reinforcement in end-block for post tensioned tendons

13.5.1.1 Externally mounted anchorage

(1) Individual Square End Block

The bursting tensile force, F_{bst} existing in an individual square end block loaded by a symmetrically placed square anchorage or bearing plate, may be derived from **Table 13.1** and **Fig. 13.2**.

Table 13.1 Design Bursting Tensile Forces in End Blocks

Y_{po} / Y_o	0.3	0.4	0.5	0.6	0.7
F_{bst} / P_k	0.26	0.23	0.19	0.16	0.12

Note: For intermediate values linear interpolation may be made.

where

$2Y_o$ = is the side of end block.

$2Y_{po}$ = is the side of loaded area.

When circular anchorages or bearing plates are used, the side of the equivalent square area should be used.

P_k = is the load in the tendon

F_{bst} = is the bursting tensile force.

This force, F_{bst} will be distributed in a region extending from $0.2Y_o$ to $2Y_o$ from the loaded face of the end block as shown in **Fig. 13.2**. Reinforcement provided in this region to sustain the bursting tensile force may be calculated based on a tensile strength of $0.87f_y$ except that the stress should be limited to a value corresponding to a strain of 0.001 when the concrete cover to the reinforcement is less than 50 mm.

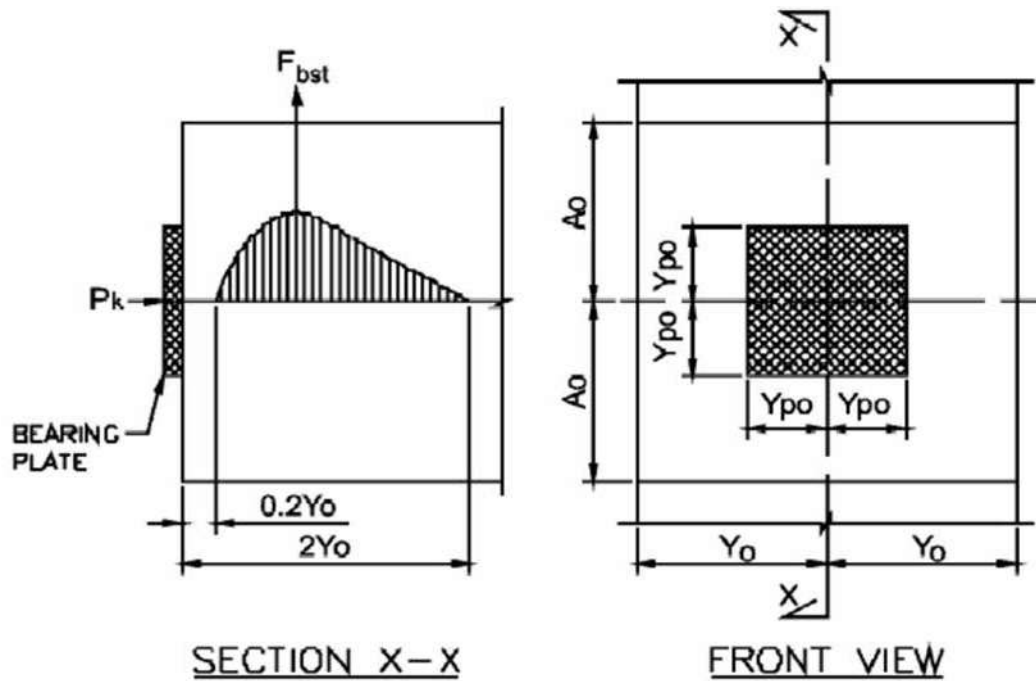

Fig. 13.2 Loaded Face of the End Block

(2) Rectangular End Block ($2A_0 \times 2Y_0$)

In the rectangular end blocks, the bursting tensile forces in the two principal directions can be assessed on the similar basis as in **Table 13.1**. The shape of the loaded area of anchorage should be taken as a concentric rectangular area having the same shape as the end block and the same area as that of actual anchorage. Alternatively, the higher of the two reinforcements can be provided in both directions.

13.5.1.2 *Internal (embedded) anchorages*

Where the anchorages are embedded in concrete, the concrete behind anchorages is subjected to complex tri-axial set of forces where the main compressive thrust is limited to remain below the multi-axial compressive capacity and tensions in transverse directions are taken up by suitable reinforcement. Although theoretical assessment may be possible, the design and detailing is made as per recommendations of the manufacturers of the anchorage system.

13.5.1.3 *Group of anchorages*

Where groups of anchorages or bearing plates occur, the end block should be divided into a series of symmetrically loaded prisms and each prism treated in the same manner. In detailing the reinforcement for the end block as a whole, it is necessary to ensure that the groups of anchorages are appropriately tied together. Special attention should be paid to end blocks having a cross-section different in shape from that of the general cross-section of the beam and reference should be made to specialist literature. Compliance with the above requirements will generally ensure that bursting tensile forces along the loaded axis are provided for. In case where large concentrated tendon forces are involved alternative methods of design based on specialist literature and manufacturer's data as per Clause 13.5.3 may be more appropriate.

13.5.2 *Spalling reinforcement for post-tensioned tendons*

Consideration should also be given to the spalling tensile stresses that occur in end blocks. Where the anchorage or bearing plates are highly eccentric, these stresses reach a maximum at the loaded face. The end face of anchorage zone shall be continuously reinforced to prevent edge spalling. Reinforcement shall be placed as close to the end face as possible.

13.5.3 *Bursting reinforcement for pre-tensioned members*

The bursting resistance of pre-tensioned anchorage zone provided by vertical reinforcement in the ends of pre-tensioned beams shall be taken as:

$$P_r = f_s A_s$$

where

- f_s = Stress in steel not exceeding 140 MPa
- A_s = Total area of vertical reinforcement located within the distance $h / 5$ from the end of the beam (mm²).
- h = Overall depth of precast member (mm)

The bursting resistance P_r shall not be less than 4 percent of the prestressing force at transfer.

The end vertical reinforcement shall be as close to the end of the beam as practicable.

13.5.4 *Intermediate Anchorages*

13.5.4.1 *General*

Intermediate Anchorages are those post tensioned anchorages that are not located at the end surface of a member or segment (see fig 13.3). They are usually in the form of embedded anchors, blisters, ribs, or recess pockets. In case of intermediate anchorages, tensile stresses may develop behind the anchorages. These tensile stresses result from the compatibility of deformations ahead of and behind the anchorage. The force of the tendon must be carefully distributed to the flange/web by reinforcement in front as well as behind the anchorage. For intermediate anchorages, the anchorage zone shall be considered to extend for a distance not less than the transverse dimension of the flange/ web to which it is anchored.

13.5.4.2 Intermediate anchorages shall not be used in regions where tensile stress exceeding 1 MPa is generated behind the anchor (upto 1.0x depth of section) from other actions under relevant SLS combination. Whenever practical, blisters should be located in the corner between flange and webs or shall be extended over the full flange width or web height to form a continuous rib.

If isolated blisters are required to be used in the middle of a flange or web, local shear, bending, and direct force effects, shall be adequately considered in the design. For flange/web thickness up to 225mm, an upper limit of force equivalent to 12 strands of 12.7mm diameter shall be adhered to for tendons anchored in intermediate blisters supported only by the flange or web.

13.5.4.3 Tie-back Reinforcement

Tie-back reinforcement is the one required to take care of the tensile stresses indicated in 13.5.4.1. For this purpose bonded reinforcement shall be provided to tie-back at least 25 percent of the unfactored intermediate anchorage stressing force into the concrete section behind the anchorage. Stresses in this bonded reinforcement shall not exceed 240 MPa. The anchorage force of the tendon must be carefully distributed to the main structure by reinforcement.

If permanent compressive stresses are generated behind the anchor from other actions, the amount of tie-back reinforcement may be reduced using the following equation

$$T_{ia} = 0.25 P_s - f_{cb} A_{cb}$$

where:

T_{ia} = the tie-back tension force at the intermediate anchorage (N)

P_s = the maximum unfactored anchorage stressing force (N) transmitted to the anchor plate

f_{cb} = the unfactored compressive stress in the region behind the anchor (MPa) due to permanent load

A_{cb} = the area of the continuing cross-section within the extensions of the sides of the anchor plate or blister, i.e., the area of the blister or rib shall not be taken as part of the cross-section (mm²)

The tie-back reinforcement shall be concentrated within one anchor plate on either side of the tendon axis. It shall be fully anchored so that the yield strength can be developed at a distance of one plate width or half the length of the blister or rib ahead of the anchor as well as at the same distance behind the anchor. The centroid of this reinforcement shall coincide with the tendon axis, as far as possible. For blisters and ribs, the reinforcement shall be placed in the continuing section near that face of the flange or web from which the blister or rib is projecting.

13.5.4.4 Blister and Rib Reinforcement

Reinforcement shall be provided throughout the blisters or ribs as required for shear friction, corbel action, bursting forces, and deviation forces due to tendon curvature. This reinforcement shall extend into the flange or web and be developed by standard hooks bent around transverse bars or equivalent. Spacing shall not exceed the smallest of blister or rib height at anchor, blister width, or 150 mm, whichever is less. Reinforcement shall be provided to resist local bending in blisters and ribs due to eccentricity of the tendon force and to resist lateral bending in ribs due to tendon deviation forces. This reinforcement is normally provided in the form of ties or U-stirrups, which encase the anchorage and tie it effectively into the adjacent web and flange.

Reinforcement, as specified in earlier clauses of this Section shall be provided to resist tensile forces due to transfer of the anchorage force from the blister or rib into the overall structure.

13.5.4.5 Precast Segmental Constructions

In the case of precast segmental structure, it is not feasible to provide continuing reinforcement over the segment joints to take care of the stresses indicated in 13.5.4.1. In such cases, adequate compression, behind the intermediate anchorages, through prestressing, shall be ensured to take care of these effects in accordance with 15.3.2.1 (6).

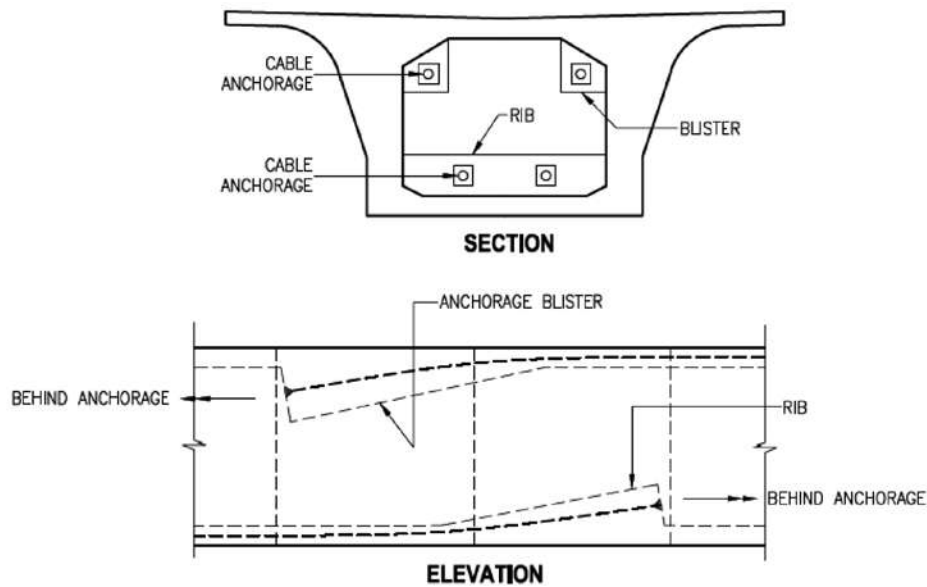

Fig. 13.3 Anchorage Blister and Anchorage Rib

13.6 Protective Grouting

- (1) Post tensioned tendons shall be bonded to concrete of the prestressed member as well as protected from corrosion by cement grout which shall fill the ducts fully, without leaving any entrapped air or water pockets, voids created by evaporation of excess water in the grout and bleeding.
- (2) Unbonded tendons placed either in ducts embedded in concrete or externally located shall be protected from corrosion by suitable fillers. Grouting by cement, wax, nuclear grade (low sulphur) grease are some of the options. For materials other than cement or such long life permanent materials, arrangements for inspection and refilling or replacement of grouting materials shall be made. Factory made coated wires/strands embedded in polyethylene ducts with suitable fill are acceptable. Manufacturer's recommendations shall be followed for the specialist materials and techniques.

13.7 Protection of Post Tensioned Tendons and Anchorages

In order to achieve a durable post-tensioning system, matching with the design service life of the structure, suitable corrosion protection of the post-tensioning system, is necessary.

The corrosion protection system shall take into account:

- (a) Temporary protection of the tendons, ducts, anchorages and all accessories from manufacturer handling storage, transport till incorporation in the structure.
- (b) Semi-permanent protection of the system in situations where the tendons and anchorages are exposed to atmosphere for an extended period of time.
- (c) Permanent protection of prestressing system applied either at the factory or at site shall be according to service environment. Special care is warranted since most parts of the tendon or other component are generally not accessible during service life.

SECTION 14

DURABILITY

14.1 General

This Section covers design for durability and suggests provisions to ensure that adequate durability is achieved.

The structure shall be designed such that deterioration over its design service life does not impair the performance of the structure below that intended, having due regard to the service environment and the anticipated level of maintenance.

One of the main characteristics influencing the durability of concrete is its permeability to the ingress of water, oxygen, carbon dioxide, chloride, sulphate and other potentially deleterious substances. Degree of permeability is governed by the constituents, the mix proportions and workmanship used in making concrete. A suitably low permeability can be achieved by having adequate cement content, low water cement ratio and ensuring complete compaction of the concrete followed by adequate curing. Use of blended cements will also help to achieve low permeability.

The factors influencing durability of concrete include:

- (1) The environment,
- (2) The cover to embedded steel,
- (3) The type and quality of constituent materials,
- (4) The cement content and water/cement ratio,
- (5) Workmanship, to obtain full compaction and efficient curing and
- (6) The shape and size of the member.

14.2 Common Mechanisms Leading to the Deterioration of Concrete Structures

Common mechanisms of deterioration of concrete structures in service are:

- (1) Corrosion of reinforcement/prestressing tendons
- (2) Frost attack
- (3) Alkali-aggregate reactions
- (4) Attack from sulphates
- (5) Attack by aggressive chemicals
- (6) Acid attack and
- (7) Abrasion

Description of the mechanisms is given in **Annexure B-2**.

14.3 Design for Durability

Basic steps in designing for durability are:

- (1) To establish the aggressiveness of the service environment (exposure condition), with respect to the various mechanisms of deterioration. Different components of the structure can be exposed to different service environments.

- (2) To select the type of structure suitable for the service environment.
- (3) To select the appropriate materials, mix proportions, workmanship, design and detailing, including minimum cover to steel.

14.3.1 *Classification of exposure conditions*

The general environment to which the concrete structure will be exposed during its service life is classified into four levels of severity. In doing so, it is possible that the classification relates to specific mechanisms of deterioration. The relative importance of the various mechanisms will vary from region to region in a country and no generally applicable ordering of the mechanisms can be made. However, there seems no doubt that the commonest and most serious form of degradation worldwide is corrosion of reinforcement. It can also be stated that, of the two initiating mechanisms for corrosion viz. - carbonation and chlorides; chlorides have caused the greater amount of damage by far. The classification in **Table 14.1** caters essentially to corrosion of steel in concrete.

Table 14.1 Classification of Service Environment

Sl. No	Environment	Exposure Conditions
(1)	Moderate	Concrete dry or permanently wet; concrete continuously under water; low humidity (Relative humidity < 50 %); humid (Relative humidity > 70 %)
(2)	Severe	Wet, rarely dry; moderate humidity (relative humidity \geq 50 % and \leq 70 %), completely submerged in sea water below mid-tide level; concrete exposed to coastal environment.
(3)	Very severe	Concrete exposed to air-borne chloride in marine environment; freezing conditions while wet.
(4)	Extreme	Cyclic wet and dry, concrete exposed to tidal, splash and spray zones in sea, concrete in direct contact with aggressive sub-soil/ground water, concrete in contact with aggressive chemicals.

Note: Relative Humidity is as defined in note No.(3) below **Table 6.9**

14.3.2 *Durability provisions*

14.3.2.1 *Concrete mix proportions and cover*

Presence of moisture is necessary for most of the deleterious actions to proceed and low permeability of concrete is a prerequisite for durability. Greater impermeability is achieved primarily by the control of water/cement ratio and selection of the cement type.

The water/cement ratio governs the strength of concrete, and strength classes are accordingly chosen, as an indirect control on these parameters.

Cover (or clear cover) is the distance from the concrete surface to the surface of the nearest reinforcement, including links, stirrups and surface reinforcement. Cover is more important from the consideration of corrosion of steel in concrete. The cover should at least be equal to the depth of likely chloride ingress by diffusion over a time period equal to the design service life. Chloride diffusion coefficient in concrete depends upon the water/cement ratio and the cement type; it is lower for blended cements, and lower water/cement ratios. It is possible to select combinations of the water cement ratio and cover

thickness to achieve the objective. However, the selection of cover should also take into account other structural aspects like safe transmission of bond forces and control of crack width.

Taking these considerations into account, the requirements of concrete mix properties and cover for different exposure conditions considered in **Table 14.1**, for 20 mm size aggregate are given in **Table 14.2**.

**Table 14.2 Durability Recommendations for Service Life of at Least 100 Years
(20 mm Aggregate)**

Exposure Condition	Maximum water/cement ratio	Minimum cement content, kg/m³	Minimum grade of concrete	Minimum Cover, mm
Moderate	0.45	340	M25	40
Severe	0.45	360	M30	45
Very Severe	0.40	380	M40	50
Extreme	0.35	400	M45	75

Notes.

- (1) All four recommendations given in the Table for a particular exposure condition, shall be satisfied.
- (2) For post tensioned tendons, the minimum clear cover measured from the outside of the sheathing shall be 75 mm.
- (3) For pre-tensioned tendons, minimum cover shall be 65 mm.
- (4) Minimum cover shown in **Table 14.2** can be reduced by 5 mm in case of factory made precast concrete elements, high performance concrete, use of stainless steel reinforcement, or controlled permeability formwork (refer Clause 14.4.1). In case more than one of the above measures are adopted the reduction should not exceed 10 mm.
- (5) The term cement for maximum w/c ratio and minimum cement content in **Table 14.2** includes all cementitious materials inclusive of additions mentioned in Clause 18.4.
- (6) For plain cement concrete, with or without surface reinforcement, the minimum grade of concrete can be lowered by 5 MPa and maximum water/cement ratio exceeded by 0.05.
- (7) For all foundations and elements below ground level minimum cover shall be 75 mm.
- (8) For design service life of 50 years or less, the minimum cover can be reduced by 5 mm.

14.3.2.2 Adjustments for other aggregate sizes

For aggregate sizes other than 20 mm, the minimum cement content shown in **Table 14.2** shall be adjusted as per **Table 14.3**.

**Table 14.3 Adjustments in Cement Content for Aggregates
of Size other than 20 mm Size**

Aggregate size, mm	Adjustment in minimum cement content in Table 14.2, kg/m³
10	+40
20	0
40	-30

14.3.2.3 Chloride content

All constituents of concrete, viz. cement, aggregate, water, chemical admixture and mineral admixture, may contain chlorides. Concrete may be contaminated by diffusion of chlorides from the external environment. Total acid soluble chloride content in the concrete mix, expressed as chloride ions, shall not exceed the following values by mass of cementations material.

Prestressed concrete	- 0.10 percent
Reinforced concrete (in severe, very severe or extreme exposure conditions)	- 0.20 percent
Reinforced concrete in moderate exposure conditions	- 0.30 percent

14.3.2.4 Sulphate content

Sulphates are present in cements, in some aggregates and mix water. They can also be imbibed from the service environment e.g. coastal environment. The total water-soluble sulphate content of the concrete mix, expressed as SO_3 , shall not exceed 4 percent by mass of cement in the mix.

14.3.2.5 Maximum cement content

Cement content (excluding fly ash, GGBS or Silica Fume) shall not exceed 450 kg/m³.

14.4 Additional Provisions for Specific Mechanisms of Deterioration

Some additional provisions for different mechanisms of deterioration are given below.

14.4.1 Corrosion of reinforcement

The normal way to design against corrosion is to ensure that there is an adequate cover to the reinforcement and that the concrete in the cover region is of a high quality and is well cured. In extreme environments, however, there are other measures which may have to be adopted, such as:

- (1) Use of galvanized reinforcement or reinforcement with fusion bonded epoxy coating.
- (2) Use of surface coatings to the concrete to inhibit the ingress of chlorides or carbon dioxide. Such coatings need periodic renewal.
- (3) Use of waterproofing membrane over the bridge deck.
- (4) Use of controlled permeability formwork (CPF) liners, which effectively reduce the water-cement ratio of cover concrete and reduce the chloride diffusion into the concrete.
- (5) Application of cathodic protection to the structure.
- (6) Use of stainless steel reinforcement.

One major factor in the avoidance of corrosion problems is the form of the structure. Areas of exposed concrete on which water can stand or can drain across, are particularly at risk.

14.4.2 Sulphate attack

Depending upon the concentration of SO_3 ions in soil, subsoil or ground water, appropriate protective measures comprise selection of proper type of cement, mix proportions and protective coatings in severe cases. The details are given in **Table 14.4**.

Table 14.4 Requirements for Concrete Exposed to Sulphate Attack

Class	Concentration of sulphates as SO_3			Type of cement (Note ii)	Minimum cement content, kg/m^3	Maximum water cement ratio	Minimum grade of concrete
	In soils		In ground water, g/l				
	Total SO_3 , %	SO_3 in 2:1 water: soil extract, g/l					
1	Traces	<1.0	<0.3	OPC, PPC or PSC	280	0.5	M25
2	0.2 to 0.5	1.0 to 1.9	0.3 to 1.2	OPC, PPC or PSC	330	0.5	M25
				-SRPC	310		
3	0.5 to 1.0	1.9 to 3.1	1.2 to 2.5	-SRPC	330	0.5	M25
				-PPC or PSC	350		
4	1.0 to 2.0	3.1 to 5.0	2.5 to 5.0	-SRPC	370	0.45	M35
5	>2	>5.0	>5.0	-SRPC With protective coatings	400	0.4	M40

Notes :

- (i) If the requirements of maximum water/cement ratio, minimum grade of concrete and minimum cement content from other durability considerations as given in **Table 14.2** are more stringent than those given in **Table 14.4** then the former will govern.
- (ii) Type of cements: OPC: Ordinary Portland Cement, PPC: Portland Pozzolona Cement, PSC: Portland Slag Cement, SRPC: Sulphate Resisting Portland Cement.
- (iii) Where chloride is encountered along with sulphates in soil, ground water or in ambient air, ordinary portland cement with C_3A content from 5 to 8 percent shall be desirable to be used in concrete instead of sulphate resisting cement.

14.4.3 *Alkali – silica reaction*

The alkali-silica reaction can be alleviated by the following methods:-

- (1) Use of aggregates which have been found to perform satisfactorily in practice,
- (2) Use of non-reactive aggregate from alternate sources,
- (3) Use of low-alkali OPC having total alkali content not more than 0.6 percent (Na_2O equivalent). Further advantage can be obtained by use of fly ash, ground granulated blast furnace slag or silica fume as part replacement of low alkali OPC. In such cases, fly ash content should be at least 20 percent or slag content at least 50 percent,
- (4) Measures to reduce the degree of saturation of concrete during service such as use of impermeable membranes,
- (5) Limiting the cement content of the concrete mix and thereby limiting total alkali content in the concrete mix,

For more guidance, specialist literature may be referred.

14.4.4 *Frost attack*

Frost damage can be avoided by the following methods:-

- (1) Protecting the concrete from saturation.
 - (2) Using an air-entrained concrete mix. The small bubbles of entrained air within the matrix can provide pressure relief. The minimum amount of entrained air should be 3.5 percent for 20 mm size aggregate, and greater for smaller sizes. Air-entraining admixture should conform to IS 9103.
 - (3) Using high-strength concrete, with compressive strength of 45 MPa or more.
-

SECTION 15
DETAILING: GENERAL REQUIREMENTS

15.1 General

- (1) The following detailing requirements apply to all structures using normal weight concrete, uncoated steel for reinforcement and prestressing. These are supplemented for specific applications by additional rules in Sections 16 & 17.
- (2) Modifications in provisions required for use of coated steels are given in Clause 15.4.

15.2 Reinforcing Steel**15.2.1 Spacing of bars**

- (1) The spacing of bars shall be such that the concrete can be placed and compacted satisfactorily for the development of adequate bond.
The aggregate size, d_g shall be chosen to permit adequate compaction around the bars where d_g is the nominal size as per IS 383.
- (2) The clear distance, (horizontal and vertical) between individual parallel bars or horizontal layers of parallel bars shall not be less than maximum of (a) largest bar diameter (b) ($d_g + 10$ mm) or (c) 20 mm.
- (3) Where bars are positioned in separate horizontal layers, the bars in each layer should be located vertically above each other. Where access for vibrator needle is required, the spacing between columns of bars shall not be less than 50 mm.
- (4) Lapped bars may touch one another within the lap length.

15.2.2 Permissible bending

The minimum bend diameter of the bar shall be such as to avoid bending cracks in the bar and crushing or splitting of the concrete inside the bend.

The minimum diameter of the mandrel used for bending should be not less than the values given in **Tables 15.1 & 15.2**.

Table 15.1 Minimum Mandrel Diameters for Bending of Bent-up Bars and Curved Bars to Avoid Splitting/Crushing of Concrete (ϕ : Diameter of Bar)

Value of concrete cover, perpendicular to plane of curvature	Bent-up Bars or Curved Bars	
	Plain (Fe 240)	HSD
$\leq 3 \phi < 50$ mm	15ϕ	20ϕ
$> 3 \phi > 50$ mm	10ϕ	15ϕ

Table 15.2 Minimum Mandrel Diameters for Cold Bending of Bars to Avoid Bending Cracks (ϕ : Diameter of Bar)

Type of Steel	For Hooks, Bends, Loops	
	$\phi < 20$ mm	$\phi \geq 20$ mm
Plain bars, (Fe 240)	2.5ϕ	5ϕ
HSD Bars	4ϕ	7ϕ

15.2.3 Bond

15.2.3.1 Bond conditions

The quality of the bond depends on the surface pattern of the bar, on the dimension of the member and on the position and inclination of the reinforcement with respect to direction of concreting.

(1) Favourable bond conditions

For normal weight concrete, the bond conditions are considered to be favourable for:

- (a) All bars, with an inclination between 45° and 90° to the horizontal (**Fig. 15.1.a**).
- (b) All bars which are horizontal or have inclination upto 45° to the horizontal and are:
 - (i) either placed in members whose depth in the direction of concreting does not exceed 250 mm (**Fig. 15.1.b**).
 - (ii) or embedded in members with a depth greater than 250 mm, and when concreting is completed, are:
 - either in the lower half of the member (Fig. 15.1 c),
 - or at least in concrete portion located below 300 mm from its top surface (Fig 15.1 d)

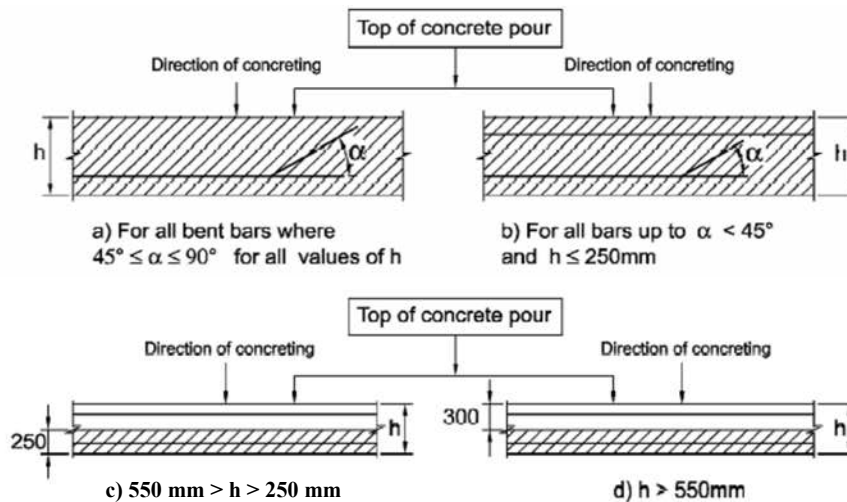

(Favourable Bond Condition in Hatched Zones and Unfavourable Bond in Unhatched Zone)

Fig. 15.1 Description of Bond Conditions

(2) Unfavourable-bond conditions

All other conditions are considered as unfavourable bond conditions.

15.2.3.2 *Ultimate bond stress*

- (1) The ultimate bond strength shall be sufficient to prevent bond failure.
- (2) In favourable bond conditions, the design values for the ultimate bond stress f_{bd} are given in **Table 15.3**.

Table 15.3 Design Values f_{bd} (N/mm²) for Favourable Bond Conditions
[These Values Incorporate (γ_c) Value Equal to 1.5]

Concrete Grade f_{ck} MPA → Re-Bar Grade where ↓	M 20	M 25	M 30	M 35	M 40	M 45	M 50	M 55	M 60 and Higher
Plain Bars Fe 240	1.0	1.1	1.2	1.3	1.4	1.45	1.5	1.6	1.7
High Strength Deformed bars where $\phi \leq 32$ mm (Conforming to IS:1786)	1.95	2.25	2.7	3.0	3.2	3.4	3.75	4.0	4.3

Notes:

- (i) For unfavourable bond condition, the values given above should be multiplied by factor of 0.7.
- (ii) For $\phi > 32$ mm, additional rules are given in Clause 15.2.6.
- (iii) For value of $\gamma_c = 1.2$. The above values can be increased by a factor $\frac{1.5}{1.2} = 1.25$
- (iv) For concrete grade higher than M60, recommended f_{bd} is limited due to increased brittleness of concrete.

15.2.3.3 *Basic anchorage length*

- (1) The basic anchorage length l_b is the straight length required for anchoring the force $A_s f_{yd}$ in a bar, assuming constant bond stress equal to f_{bd} . In determining the basic anchorage length, the type of the steel and the bond properties of the bars shall be taken into consideration.

The basic anchorage length required for the anchorage of a bar of diameter ϕ is:

$$l_b = (\phi/4) (f_{yd} / f_{bd}) = k \cdot \phi \quad \text{Eq.15.1}$$

Where f_{yd} is design ultimate stress = $f_y / 1.15$.

Values for k for different grades of concrete and steel are given in **Table 15.4**.

- (2) For bent bars the basic anchorage length should be measured along the centre line of the bar.

Table 15.4 Value of k for Favourable Bond
(These Values incorporate ($\gamma_c=1.5$))

Concrete Grade MPA → Re-Bar Grade ↓	M 20	M 25	M 30	M 35	M 40	M 45	M 50	M 55	M 60 and Higher
Plain Bars Fe 240	52	47	43	40	37	36	35	33	31
HSD Bars Fe 415 & Fe 415D	45	39	33	30	28	27	24	23	21
HSD Bars Fe 500 & Fe 500D	54	47	40	36	34	32	29	27	25
HSD Bars Fe 550 & Fe 550D	60	52	44	40	37	35	32	30	28
HSD Bars (Fe 600)	65	57	48	43	41	38	35	33	30

Notes:

- (1) For unfavourable bond condition the above values should be multiplied by factor of 1.43.
- (2) For $\phi > 32$ mm, these lengths should be increased by multiplying factor $\left(\frac{100}{132-\phi}\right)$

15.2.4 Anchorage of longitudinal reinforcement

15.2.4.1 General

- (1) The reinforcing bars shall be so anchored that while their compressive or tensile forces are transmitted to the concrete the longitudinal cracking or spalling of concrete is avoided. Transverse reinforcement shall be provided in accordance with Clause 15.2.5.1.3. In calculation of area of transverse reinforcement, the steel provided for any other reason such as distribution steel in slabs or shear reinforcement in beams, can be counted.
- (2) Where mechanical devices are used, their effectiveness shall be proven and capacity to transmit the concentrated force at the anchorage shall be established by tests.

15.2.4.2 Anchorage methods

- (1) The usual methods of anchorage for plain and HSD bars are shown in **Fig. 15.2**. Straight anchorages (b) or bends (c) should not be used to anchor plain bars of more than 8 mm diameter.
- (2) Anchorage for bars in compression shall be developed by straight anchorage. Hooks and bends, if provided for any other reason, shall be deemed not effective in providing anchorage in compression. The value of l_b in compression should be same as l_b in tension.

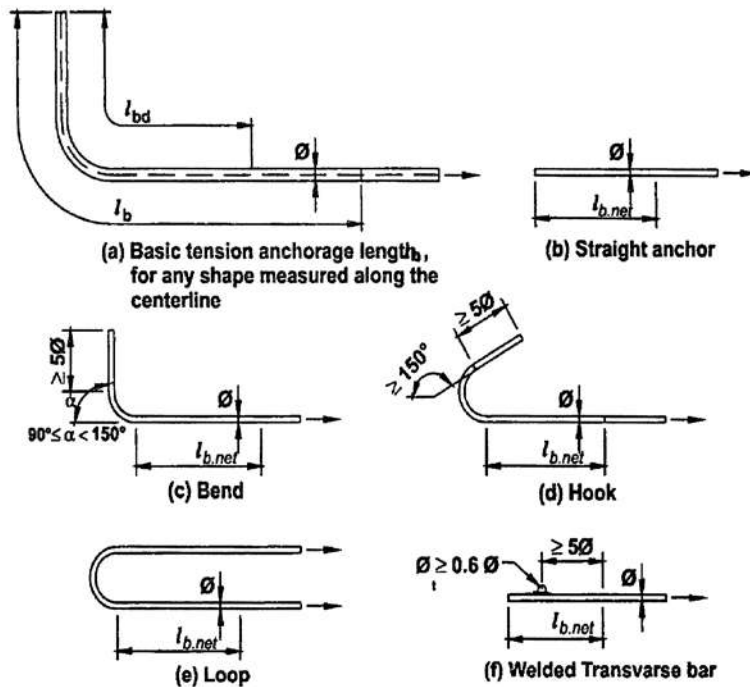

Note: For $l_{b.net}$ values refer clause 15.2.4.3

Fig. 15.2 Methods of Anchorage

15.2.4.3 Design anchorage length

(1) Bars

The design anchorage length $l_{b.net}$ may be calculated from :

$$l_{b.net} = \alpha_a l_b \frac{A_{s.req}}{A_{s.prov}} \geq l_{b.min}$$

Eq. 15.2

Where

$l_{b.net}$: as shown in Fig. 15.2.

$l_b = k \cdot \phi$: as given by Eq. (15.1) and Table 15.4.

$A_{s.req}$ and $A_{s.prov}$: Area of reinforcement required by design and that actually provided, respectively.

α_a is a coefficient which has the following values.

$\alpha_a = 1$ for straight bars and bars in compression.

$\alpha_a = 0.7$ for bent bars and loop bars in tension, if the concrete cover perpendicular to the plane of bending is at least 3ϕ in the region of the hook, bend, and bars having transverse welded bars (Fig. 15.2)

$l_{b.min}$: Denotes the minimum anchorage length.

- for anchorages in tension $l_{b.min} = 0.3 l_b$

- for anchorages in compression. $l_{b.min} = 0.6 l_b$

$l_{b.min}$: shall not be less than 10ϕ or 100 mm

(2) Anchorage of links and shear reinforcement

- (a) The anchorage of links and shear reinforcement shall normally be achieved by means of hooks, bends or by welded transverse reinforcement. For hooked or bent bar, a transverse bar of same or larger dia should be provided inside hook or bend.
- (b) For the permissible curvature of hooks and bends, see **Table 15.2**.
- (c) The anchorage as a whole is considered to be satisfactory, where either (i) or (ii) below is satisfied.
- (i) The curve of a hook or bend is extended by a straight length which is not less than 5ϕ or 50 mm if it is a continuation of an arc of 135° or more; **Fig. 15.3(a)**, or 10ϕ or 70 mm if it is a continuation of any arc of 90° , **Fig. 15.3(b)**.
- (ii) Near the end of a straight bar there are :
- either two welded transverse bars, where dia. is not less than 0.7 dia. of anchored bar, **Fig. 15.3(c)**.
 - or a single welded transverse bar, the diameter of which is not less than 1.4 times the diameter of the bar, **Fig. 15.3(d)**.

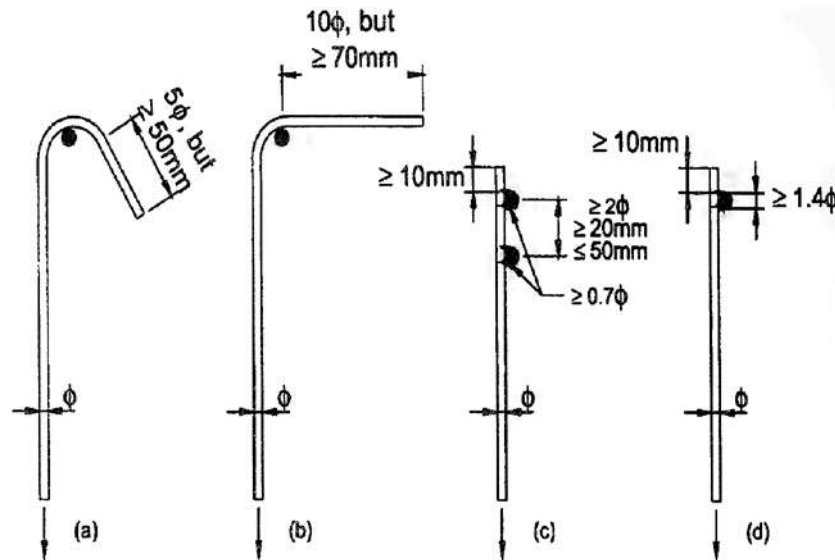

Note: For (c) and (d) cover should not be less than 3ϕ or 50 mm

Fig. 15.3 Anchorage of Links and Shear Reinforcement

15.2.5 Splices

Splices of reinforcement shall be formed by

- (1) Laps of bars with straight ends or with end hooks.
- (2) Welding
- (3) Mechanical devices

The detailing of splices between bars shall be such that the transmission of forces from one bar to the next is assured and spalling of concrete or unacceptable crack widths (from durability point of view), do not occur in the neighbourhood of the splice.

15.2.5.1 Splices of bars by laps

(1) Arrangement of lapped splices

- (a) As far as possible:
 - Laps should not be located in areas of high stress
 - Laps shall be staggered.
 - Exceptions are however allowed under conditions as described in item (e) & (f).
- (b) The clear space between the two lapped bars in a splice should not be greater than 4ϕ or 50 mm as indicated in **Fig. 15.4 (a)**; otherwise the lap length should be increased by a length equal to the clear space where it exceeds 4ϕ .
- (c) For adjacent laps, the clear longitudinal distance between two laps and transverse distance between bars be as indicated in **Fig. 15.4 (b)**.
- (d) Transverse reinforcement as given in Clause 15.2.5.1.3 shall be provided for avoiding spalling or cracking of concrete.
- (e) Where provisions of (b) above are satisfied and the bars are all in one layer, 100 percent lapping of bars in tension at one section may be permitted for HYSD bars only. Where bars are in several layers the percentage should be reduced to 50 percent.
- (f) All bars in compression and secondary (distribution) reinforcement may be lapped at one section except where ductile detailing is required.

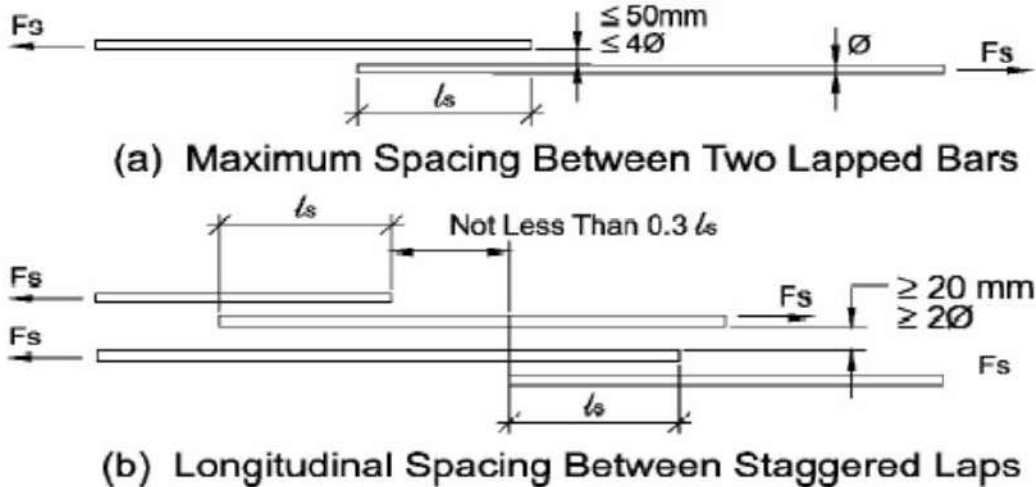

Fig. 15.4 Arrangement of Splices

(2) Lap length of splices

The lap length l_s shall be (Fig. 15.4)

$$l_s = l_{b.net} \cdot \alpha_l \geq l_{s.min}$$

Eq. 15.3

where

$l_{b.net}$ is anchorage length according to Eq. 15.2

$l_{s.min}$ = maximum of $0.3 \cdot \alpha_l \cdot l_b$, or 15ϕ or 200 mm

The Coefficient α_1 takes the following values:

Percentage of lapped bars relative to total cross-sectional area	<25%	33%	50%	>50%
α_1	1	1.15	1.4	1.5

- (3) Transverse reinforcement
- (a) If the diameter of the lapped bars is less than 20 mm, or if the area of lapped bars in any one section is less than 25 percent of total area of bars at that section, then the minimum transverse reinforcement provided for other reasons (e.g. shear reinforcement, distribution bars) is considered as sufficient.
- (b) If $\phi \geq 20$ mm, then the total transverse reinforcement should be placed between the longitudinal reinforcement and the concrete surface, and have a total area [sum of all steel placed in parallel plane to the layer of the spliced reinforcement, (**Fig. 15.5**)], of not less than the area A_s of one spliced bar ($\sum A_{st} \geq 1.0 A_s$).
- (c) For the distribution of the transverse reinforcement **Fig. 15.5** applies.
- (d) For splicing of bars in beams and columns the stirrups or links provided for other considerations can be taken into account to satisfy the requirement of (b) and their spacing shall not exceed 150 mm.

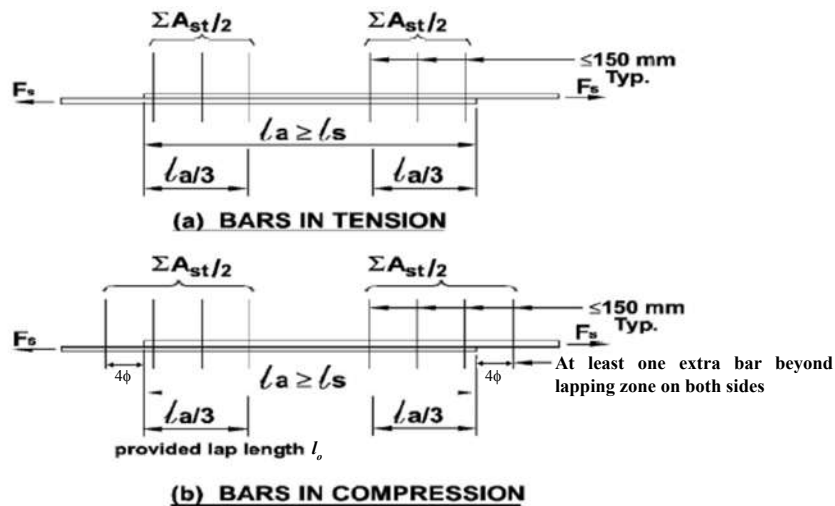

Fig. 15.5 Detailing of Transverse Reinforcement at Lapped-Splices

15.2.5.2 Splicing by welding

Welded joints may be used subject to the following :

- (1) Welding of Fe 240 grade bars conforming to IS 432 shall be permitted. Welding of other grades of bars shown in **Table 6.1** is generally not recommended except in special cases mentioned in (8) below.
- (2) In special cases the HSD bars conforming to IS 1786 may be welded after confirming that the equivalent carbon percentage calculated from the chemical compositions as given below are within the limitations of CE mentioned below:

For guaranteed weldability, the Carbon Equivalent, CE using the formula:

$C.E = C + \frac{Mn}{6} + \frac{Cr+Mo+V}{5} + \frac{Ni+Cu}{15}$ shall not be more than 0.53 percent, when microalloys/low alloys are used. When microalloys/low alloys are not used, carbon equivalent using the formula:

$C.E = C + \frac{Mn}{6}$ shall not be more than 0.42 percent.

Reinforcement bars/wires with carbon equivalent above 0.42 percent should, however be welded with precaution. Use of low hydrogen basic coated electrodes with matching strength bars/wires is recommended.

- (3) Welding shall conform to IS 2751 and IS 9417 except as provided herein.
- (4) Generally, shop welding in controlled conditions is to be preferred, where feasible. Site welding where necessary shall, however, be permitted when the facilities, equipment, process, consumables, operators, welding procedure are adequate to produce and maintain uniform quality at par with that attainable in shop welding to the satisfaction of the engineer.
- (5) Welding may be carried out by metal arc welding process. Oxyacetylene welding shall not be permitted. Any other process may be used subject to the approval of the engineer and necessary additional requirements to ensure satisfactory joint performance. Precautions on over heating, choice of electrode, selection of correct current in arc welding etc., should be strictly observed.
- (6) All bars shall be butt welded except for smaller diameter bars with diameter of less than 20 mm which may be lap welded. Single-V or Double-V butt joints may generally be used. For vertical bars single bevel or double bevel butt joints may be used.
- (7) Welded joints shall be located well away from bends and not less than twice the bar diameter away from a bend.
- (8) Joint welding procedures which are to be employed shall invariably be established by a procedure specification and shall be qualified prior to use by tests as prescribed in IS 2751. All welders and welding operators to be employed shall have to be qualified by tests prescribed in IS 2751. Inspection of welds shall conform to IS 822 and destructive or non-destructive testing may be undertaken when deemed necessary. Joints with weld defects detected by visual inspection or dimensional inspection shall not be accepted.

15.2.5.3 *Splicing by mechanical devices*

- (1) Bars may be spliced with mechanical devices, e.g. by special grade steel sleeves swaged on to the bars in end to end contact or by threaded couplers. A mechanical splice including its connecting elements shall develop, in tension or compression, at least 125 per cent of the characteristic strength f_y .
 - (a) For established systems the design shall be based on manufacturer's test certificate of ultimate strength with appropriate safety factor to be selected by the designer. In addition, field testing on selected samples from actual supply at site shall be carried out, both for acceptance and as quality control tool.
 - (b) For new systems acceptance testing shall be carried out in laboratories. In addition, field testing on selected samples from actual supply at site shall be carried out, both for acceptance and as quality control tool.

- (2) At location of mechanical splices reduction in minimum cover may be accepted but should not be less than 30 mm.

15.2.6 Additional rules for high yield steel deformed (HYSD) bars exceeding 32 mm in diameter

15.2.6.1 General

- (1) The rules given below are complementary to those given in Clause 15.2.3.
- (2) Splicing by lapped joints shall not be used either for tension or compression bars.
- (3) Bars of $\phi > 32$ mm shall be used only in elements whose minimum depth is not less than 15 times, the diameter of the bar.
- (4) When large bars are used, adequate crack control shall be ensured either by using surface reinforcement as per Clause 16.3.4(3), or by calculation as per Section 12.
- (5) Splitting forces are higher and dowel action is greater with the use of large diameter bars. Such bars should be anchored with mechanical devices. As an alternative they may be anchored as straight bars, but links should be provided as confining reinforcement.
- (6) Generally large diameter bars should not be lapped. Exceptions include sections with a minimum dimension 1.0 m or where the stress in steel is not greater than 80 percent of the design ultimate strength.
- (7) Transverse reinforcement, additional to that for shear, should be provided in the anchorage zones where transverse compression is not present.
- (8) For straight anchorage lengths (see **Fig. 15.6** for the notation used) the additional reinforcement referred to in (7) above should not be less than the following:

- in the direction parallel to the tension face:

$$A_{sh} = 0.25 A_s n_1 \quad \text{Eq. 15.4}$$

- in the direction perpendicular to the tension face:

$$A_{sv} = 0.25 A_s n_2 \quad \text{Eq. 15.5}$$

where

A_s is the cross sectional area of an anchored bar,

n_1 is the number of layers with bars anchored at the same point in the member

n_2 is the number of bars anchored in each layer.

- (9) The additional transverse reinforcement should be uniformly distributed in the anchorage zone and the spacing of bars should not exceed 150 mm.
- (10) For surface reinforcement provisions of Section (16.5.4) applies.

The area of surface reinforcement should not be less than $0.01 A_{ct, eff}$ where $A_{ct, eff}$ is the area of cover portion outside the stirrups/links.

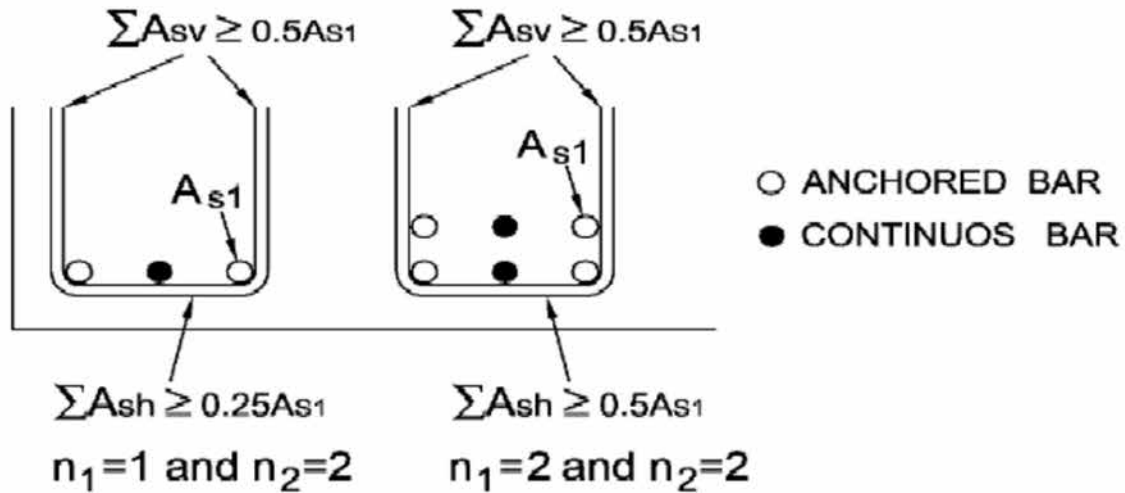

Fig.15.6 Additional Reinforcement in an Anchorage for Large Diameter Bars where there is no Transverse Compression

15.2.7 Bundled high strength deformed bars

15.2.7.1 General

(1) Bundle of same Types of Bars

Unless otherwise stated, the rules for individual bars also apply for bundles of bars. In a bundle, all the bars shall be of the same characteristics, type and grade, and preferably of same dia. Bars of different diameters can be bundled provided the ratio of diameters does not exceed 1.7.

(2) Equivalent Diameter

In design, the bundle is replaced by a notional bar having the same sectional area and the same centre of gravity as the bundle.

The ‘equivalent diameter’ ϕ_n of this notional bar is such that:

$$\phi_n = \phi \sqrt{n_b} \leq 55mm \tag{Eq. 15.6}$$

where n_b is the number of bars in the bundle, which is limited to:

- Four for vertical bars in compression and for bars in a lapped joint for lap length portion.
- Three for all other cases.

(3) Use of Equivalent Diameter

For a bundle, provision of Section 15.2.1 applies using the equivalent diameter ϕ_n , in place of ϕ . Where two touching bars are positioned one above the other, and where bond conditions are favourable, such bars need not be treated as a bundle.

(4) Minimum Concrete Cover and Spacing of Bar

The equivalent diameter ϕ_n , is taken into account in evaluation of the minimum cover and

spacing between bundles. However, the minimum cover and spacing are measured from the actual outside contour of the bundle of bars.

15.2.7.2 Anchorage of bundled bars

- (1) Bundles of bars in tension may be curtailed over end and intermediate supports. Bundles with an equivalent diameter of less than 32 mm may be curtailed near a support without the need for staggering bars. Bundles with an equivalent diameter of equal to or more than 32 mm which are anchored near a support should be staggered in the longitudinal direction as shown in **Fig. 15.7**.
- (2) For bars anchored with widely spaced anchor points (E) [**Fig. 15.7**], the diameter of the individual bar may be used in assessing l_o .

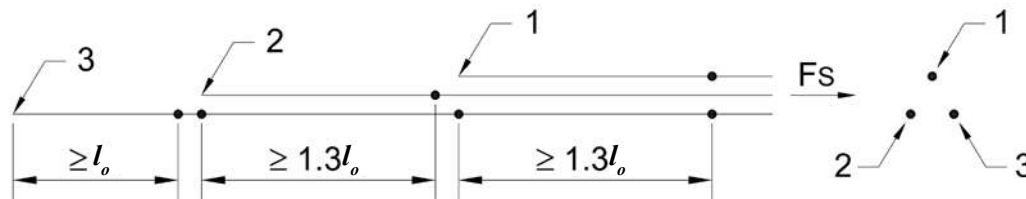

Widely Spaced Cut-off Points (E) spaced at $>1.3 l_o$.

Fig. 15.7 Anchorage of Bundles of Bars

- (3) For compression anchorages, bundled bars need not be staggered. For bundles with an equivalent diameter ≥ 32 mm, at least four links having a diameter of ≥ 12 mm should be provided at the ends of the bundle within distance of $0.33 l_o$. One number of further link should be provided just beyond the end of the curtailed bar.

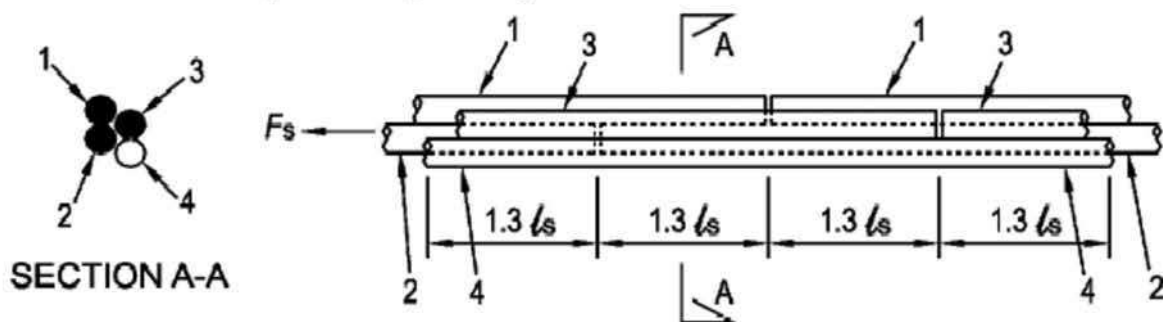

Fig. 15.8 Lap Joint in Tension including a Fourth Bar

15.2.7.3 Lapping of bundled bars

- (1) The lap length should be calculated in accordance with Clause 15.2.7.1 using equivalent diameter of bar.
- (2) Bundles which consist of two bars with an equivalent diameter < 32 mm may be lapped without staggering individual bars. In this case the equivalent bar diameter should be used to calculate l_o .
- (3) For bundles which consist of two bars with an equivalent diameter of ≥ 32 mm, or of three bars, individual bars should be staggered in the longitudinal direction by at least $1.3 l_o$. For

this case the diameter of a single bar may be used to calculate l_o . Care should be taken to ensure that there are not more than four bars in any lap cross section.

15.3 Prestressing Units

15.3.1 Arrangement of the prestressing tendons/cable ducts

15.3.1.1 General

- (1) The spacing of cable-ducts or pre-tensioned tendons shall be such as to ensure that placing and compacting of the concrete can be carried out satisfactorily and good bond can be attained between the concrete and tendons/ducts.
- (2) In case of post tensioned bonded cables, bundles of more than two ducts are not permitted. A pair of ducts placed horizontally or vertically touching each other may be permitted only in the straight portion of the cable subject to limitations given below and **Fig. 15.9**.
 - Two cables can be grouped horizontally provided each duct diameter is not more than 50 mm.
 - Two cables can be grouped vertically provided each duct diameter is not more than 110 mm.
 - Two cables shall not be bundled over the curved length of cable in the plane of curvature.
 - In case of precast segmental construction, grouping of cables is not permitted. The minimum clear distance between the ducts shall be greater of 100 mm or the outer diameter of the duct.
- (3) In case of post tensioned bonded cables, the minimum horizontal and vertical clear spacing of cables as given in **Fig. 15.9** shall be followed for major lengths of the cables.

These requirements can be relaxed locally near transition lengths of the cable, provided the minimum clear spacing between the adjacent cables along the line joining the centers of two cables is maintained as $\text{Min} [\phi_{\text{duct}} \text{ or } 50 \text{ mm}]$.

15.3.1.2 Concrete cover

The concrete cover between the inner surface of the formwork and either a pre-tensioned tendon or a duct shall be fixed with due regard to the size of the tendons or of the duct, as well as the durability requirements. Minimum cover for pre-tensioned tendons shall be not less than the maximum of the diameter of tendon, nominal aggregate size plus 10 mm, and durability requirement as per Clause 14.3.2.1. The minimum cover for post tensioned ducts shall not be less than 75 mm. Local reduction in cover at externally jointed locations of ducts is acceptable.

15.3.1.3 Horizontal and vertical spacing between cables ducts/tendons

1) Post Tensioning

The minimum clear spacing between individual ducts :

- Between single ducts vertical spacing; $\geq \phi_{\text{duct}}$ or 50 mm

- Between pair of ducts & next pair $\geq \phi_{\text{duct}}$ or 50 mm or single duct;

where ϕ_{duct} denotes the outer diameter of the duct (local reduction in spacing at externally jointed locations of ducts is acceptable).

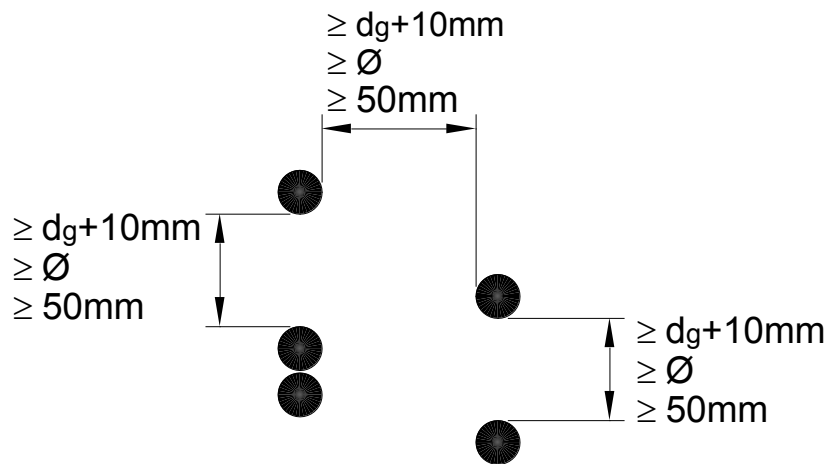

Note: Where ϕ is the diameter of post-tension duct and d_g is the maximum size of aggregate

Fig. 15.9 Minimum Clear Spacing between Ducts

(2) Unbonded Embedded Cables

Spacing and cover requirements for embedded but unbonded post tensioned tendons are the same as those for bonded cables.

(3) Pre-Tensioning

The minimum clear horizontal and vertical spacing of individual tendons is given in **Fig. 15.10**.

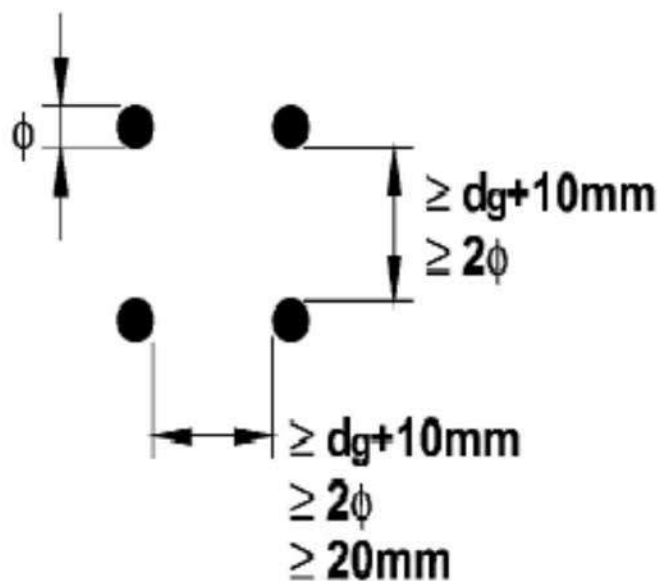

Note: Where ϕ is the diameter of pre-tensioned tendon and d_g is the maximum size of Aggregate

Fig. 15.10 Minimum Clear Spacing between Pre-tensioned Tendons

15.3.1.4 *Cable spacing for thin sections and curved portions of cables*

Refer Clause 7.10 for special checks and additional recommendations.

15.3.2 *Anchorage and couplers for prestressing tendons*

15.3.2.1 *Post-tensioning systems*

- (1) The anchorage devices used for post-tensioned tendons and the anchorage lengths in the case of pre-tensioned tendons shall be such as to enable the full design strength of the tendons to be developed.
- (2) Anchorages for post-tensioned tendons shall meet the requirements of Clause 13.2. The specification 13.2.4 are mandatory for new systems. For the established systems, the client/owner may at his discretion ask for fresh tests to verify the suitability of the system.
- (3) Where couplers are used, these shall be so placed that they do not adversely affect the load carrying capacity of the member and that any temporary anchorage which may be needed during construction can be introduced in a satisfactory manner. The requirements of minimum concrete cover over couplers and reinforcement for bursting and spalling shall be as per the specifications of manufacturers and should be subjected to acceptance tests similar to those covered in 13.2.4 for anchorages.
- (4) In general, couplers should be located away from intermediate supports.
- (5) The use of couplers for more than on 50 percent of the tendons at any cross-section should be avoided.
The distance between any two successive sections at which cables are coupled should not be closer than 1.5 m. for structural members where depth is less than 2.0 m and not closer than 3.0 m. for members of depth greater than 2.0 m.
- (6) If tendons are anchored at a construction joint or within a concrete member (whether on an external rib, within a pocket or entirely inside the member), it should be checked that a minimum residual compressive stress of at least 3 MPa is present in the direction of the anchored prestressing force, under the frequent load combination. If the minimum residual stress is not present, reinforcement should be provided to cater for the local tension beyond terminated tendon near the anchor. The check for residual stress is not required if the tendon is coupled at the anchorage considered.
- (7) Anchorage of tendons in top surface of deck shall not be permitted.
- (8) For tendons anchored in the deck slab and soffit slab, local thickening or blisters shall be so provided that minimum cover to anchorage shall not be less than 200 mm.

15.3.2.2 *Pre-tensioning systems*

- (1) Anchorage of pre-tensioned tendons In anchorage regions for pre-tensioned tendons, the following length parameters should be considered, Refer **Fig. 15.11**.
 - (a) Transmission length l_{pt} over which the prestressing force (P_o) is fully transmitted to the concrete.
 - (b) Dispersion length, l_{disp} over which the concrete stresses gradually disperse to a linear

distribution across the concrete section, is as per Eq. 15.11

- (c) Anchorage length, l_{bpd} , over which the tendon force Fpd in the ultimate limit state is fully anchored in the concrete; see Section 15.3.2.2(3) (d).

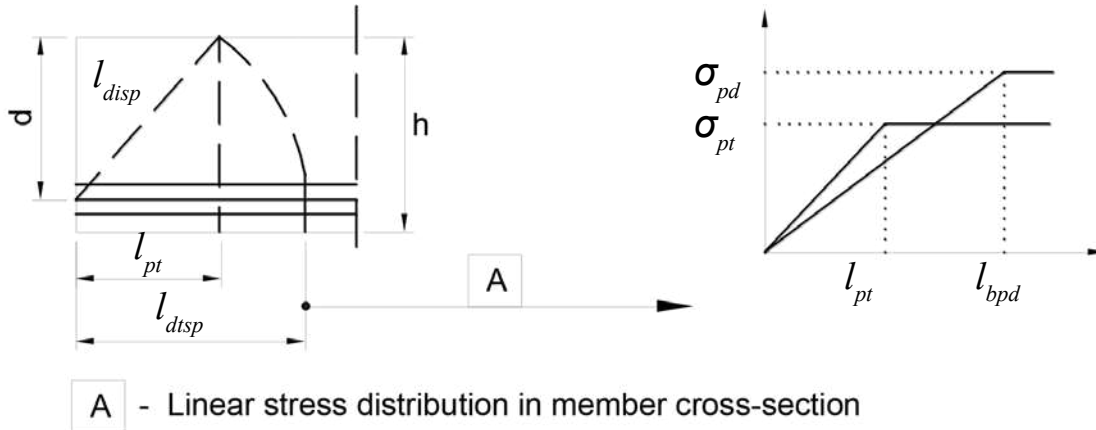

Fig. 15.11 Transfer of Prestress in Pre-tensioned Elements; Length Parameters

(2) Transfer of Prestress

- (a) At release of tendons, the prestress may be assumed to be transferred to the concrete by a constant bond stress f_{bpt}

where:

$$f_{bpt} = \eta_{pl} \eta_l f_{ctd}(t) \tag{Eq. 15.7}$$

where

η_{pl} = is a coefficient that takes into account the type of tendon and the bond situation at release.

$\eta_{pl} = 2.7$ for indented wires

$\eta_{pl} = 3.2$ for 3 and 7-wire stands.

$\eta_l = 1.0$ for good bond conditions.

= 0.7 otherwise.

$f_{ctd}(t)$ = is the design tensile strength at time of release 't' (Refer Clause 6.4.2.3), taken as $0.7 f_{ctm}(t) / \gamma_c$

Note: Values of η_{pl} for types of tendons other than those given above may be obtained by actual testing.

- (b) The basic value of the transmission length l_{pt} is given by:

$$l_{pt} = \frac{\alpha_1 \alpha_2 \phi \sigma_{pm.o}}{f_{bpt}} \tag{Eq. 15.8}$$

Where

$\alpha_1 = 1.0$ for gradual release

= 1.25 for sudden release

$\alpha_2 = 0.25$ for tendons with circular cross section

= 0.19 for 3 and 7-wire strands

ϕ = is the nominal diameter of tendon

$\sigma_{pm.o}$ = is the tendon stress just after release

- (c) The design value of the-transmission length should be taken depending on the design situation, given in Eq. 15.9 and 15.10.

$$l_{pt,1} = 0.8l_{pt} \quad \text{Eq. 15.9}$$

OR

$$l_{pt,2} = 1.2l_{pt} \quad \text{Eq. 15.10}$$

Note: The lower value is used for verifications of local stresses at release, the higher value for ultimate limit states (shear, anchorage etc.).

- (d) Concrete stresses may be assumed to have a linear distribution outside the dispersion length.

$$l_{disp} = \sqrt{l_{pt}^2 + d^2} \quad (\text{Refer Fig. 15.11}) \quad \text{Eq. 15.11}$$

- (e) Alternative build-up of prestress may be assumed, if adequately justified and if the transmission length is modified accordingly.

(3) Anchorage of Tensile Force for the Ultimate Limit State

- (a) The anchorage of tendons should be checked in sections where the concrete tensile stress exceeds $f_{ctk^{0.05}}$. The tendon force should be calculated for a cracked section, including the effect of shear according to Section 10.3.3.3(6). Where the concrete tensile stress is less than $f_{ctk^{0.05}}$ no anchorage check is necessary.

- (b) The bond strength for anchorage in the ultimate limit state is:

$$f_{bpd} = \eta_{p2} \eta_1 f_{ctd} \quad \text{Eq. 15.12}$$

where

η_{p2} is a coefficient that takes into account the type of tendon and the bond situation at anchorage

= 1.4 for indented wires or

= 1.2 for 7-wire strands

η_1 is as defined in Eq. 15.7.

- (c) Due to increasing brittleness with higher concrete strength, $f_{ctk,0.05}$ should here be limited to the value for M75.

- (d) The total anchorage length for anchoring a tendon with stress σ_{pd} is:

$$l_{bpd} = l_{pt2} + \alpha_2 \phi (\sigma_{pd} - \sigma_{pm.o}) / f_{bpd} \quad \text{Eq. 15.13}$$

where

l_{pt2} is the upper design value of transmission length = 1.2 l_{pt}

α_2 as defined in Clause 15.3.2.2 (2)

σ_{pd} is the tendon stress corresponding to the force described in (a).

$\sigma_{pm.o}$ is the prestress after all losses.

- (e) Tendon stresses in the anchorage zone are illustrated in **Fig. 15.12**.

- (f) In case of combination of ordinary and pre-tensioned reinforcement, within the same zone of concrete the anchorage capacities of each may be separately calculated and added for design verification.

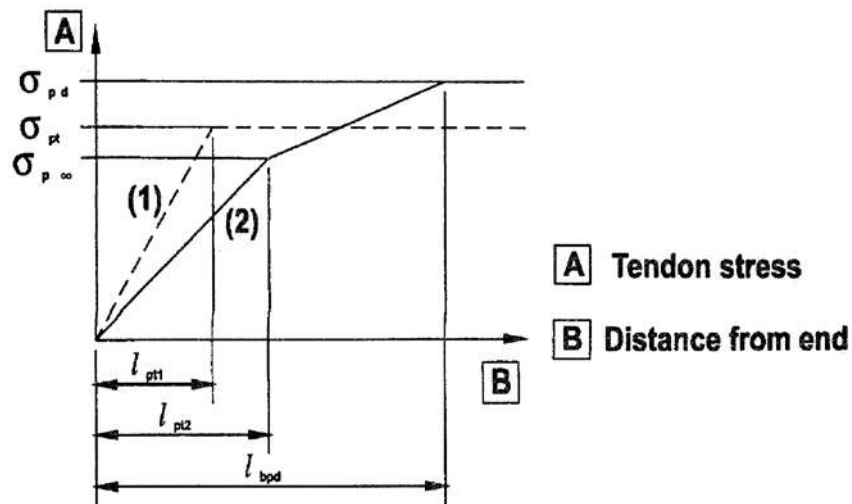

Fig. 15.12 Stresses in the Anchorage Zone of Pre-Tensioned Members: Curve (1) At Release of Tendons, Curve (2) At Ultimate Limit State.

- (4) Deviators
- (a) A deviator shall satisfy the following requirements:
- Withstand both longitudinal and transverse forces that the tendon applies to it and transmit these forces to the structure;
 - ensure that the radius of curvature of the prestressing tendon does not cause any overstressing or damage to it.
- (b) In the deviation zones the tubes forming the sheaths shall be able to sustain the radial pressure and longitudinal movement of the prestressing tendon, without damage and without impairing its proper functioning.
- (c) The radius of curvature of the tendon in a deviation zone shall not be less than 40 times the diameter of wire/strand.
- (d) Designed tendon deviations up to an angle of 0.01 radians may be permitted without using a deviator. The forces developed by the change of angle shall be considered in design.

15.4 Coated Steels

For coated steel, the bond is affected by coating system and the details of manufacture. The following values may be used:

- (1) For fusion bonded epoxy coated high strength deformed steel (HSD) and prestressing tendons, bond values given in previous Sections shall be reduced by 20 percent, and anchorage and lap lengths increased by 25 percent.
- The factor of 0.7 for reduction of above modified lap length to account for hooks and bends, shall remain unchanged.
- (2) For galvanised and stainless steel, the bond is to be taken the same as for non-galvanised steel.

SECTION 16**DETAILING REQUIREMENTS OF STRUCTURAL MEMBERS****16.1 General**

- (1) Detailing requirements given below are in addition to those given in Section 15.
- (2) Minimum areas of reinforcement are given in order to prevent a brittle failure, wide cracks and also to resist forces arising from restrained actions.
- (3) In addition to the detailing of reinforcement and prestressing steel, the dimensional restrictions on various types of elements are also covered.

16.2 Columns of Solid Section**16.2.1 Sectional dimensions**

- (1) These Clauses deal with columns of any cross-sectional shape for which the larger dimension of solid concrete section is not greater than 4 times the smaller dimension of the concrete section.
- (2) For purpose of this Section, columns are classified in two types (i) Pedestal columns and (ii) Other columns.

Pedestal columns are defined as those columns for which ratio of length/least radius of gyration is less than 12.

16.2.2 Longitudinal reinforcement

- (1) Longitudinal reinforcement for pedestal columns shall not be less than 0.15 percent of cross-sectional area of concrete.
- (2) For other columns, bar diameter shall not be less than 12 mm and spacing measured along periphery of column, not more than 200 mm.
- (3) For other columns, the minimum cross-sectional area of total longitudinal reinforcement $A_{s,\min}$ should be derived from the following condition:

$$A_{s,\min} = \frac{0.10N_{ED}}{f_{yd}} \text{ or } 0.002A_c \text{ which ever is greater,}$$

where

f_{yd} is the design yield strength of the reinforcement,

N_{Ed} is the design axial compression force.

A_c is the gross cross-sectional area of concrete.

- (4) The maximum cross-sectional area of reinforcement, outside lap portion shall not be more than $0.04 A_c$. At lap section, it shall not be greater than $0.08 A_c$.
- (5) The longitudinal bars should be distributed around the periphery of the section. For columns of circular cross-section the minimum number of bars is six. For columns having a regular

polygonal cross section or having two adjacent surfaces meeting at any angle, at least one bar shall be placed near the junction of the two surfaces.

16.2.3 *Transverse reinforcement*

Concrete columns shall have transverse reinforcement to hold the longitudinal reinforcement in place and avoid its buckling. The transverse reinforcement shall be in the form of lateral ties (polygonal links), circular rings, helix and open ties, used singly or in combination as required.

- (1) Helical reinforcement intended for making use of increased load capacity by confinement of concrete, shall satisfy requirements in (i) & (ii) in addition to other requirements given in (2) to (9).
 - (i) The end of helical reinforcement consisting of evenly spaced helical turns shall be properly anchored. The splicing of the helical turns shall be made by welding or by a lap of one and a half turns.
 - (ii) The pitch of the helical turns shall not be more than 75 mm nor more than one sixth the diameter of the core of the column.
- (2) The diameter of the transverse reinforcement shall not be less than 8 mm or one quarter of the maximum diameter of the longitudinal bar, whichever is greater.
- (3) The transverse reinforcement shall be adequately anchored.
- (4) The spacing of the transverse reinforcement along the column axis shall not exceed the lesser of the following:
 - 12 times the minimum diameter of the longitudinal bars,
 - the least dimension of the column,
 - 200 mm
- (5) At location of laps, the transverse reinforcement shall satisfy requirements of Clause 15.2.5.1.(3).
- (6) Where the direction of the longitudinal bar changes (e.g. at changes in column size), the spacing of transverse reinforcement should be calculated, taking account of the lateral forces involved. These effects may be ignored if the change of direction is less than or equal to 1 in 12.
- (7) At the location of change in dimension of concrete section (e.g. flaring of section) transverse reinforcement should be provided to balance internal transverse tensile stresses in concrete.
- (8) Every longitudinal bar (or group of longitudinal bars) placed at a corner should be held in two directions by transverse reinforcement. The included angle between these two directions should not be more than 135 degrees.
- (9) A maximum of 3 bars on one face and not more than 5 bars on two faces meeting at each corner including the corner bar, can be secured against buckling by any one set of transverse reinforcement. The distance of the farthest bar thus supported from the corner of column shall not be more than 150 mm.
- (10) No bar within a compression zone should be further than 150 mm from a restrained bar.

16.3 R.C. Walls and Wall Type Piers

- (1) These clauses deal with reinforced concrete walls of which the larger dimension measured horizontally is more than four times the smaller dimension.
- (2) The amount and proper detailing of reinforcement may be derived from FEM analysis or strut-and-tie model within the dispersal zone of concentrated loads. For walls subjected to predominantly out of plane bending, the rules of slab apply if they are more severe.

16.3.1 Vertical reinforcement

- (1) The diameter of bar should not be less than 12 mm.
- (2) The total area of the vertical reinforcement should be between $0.0024A_c$ and $0.04A_c$ outside the locations of laps of vertical steel.
- (3) This reinforcement should be provided at two faces taking into account the direct axial force and biaxial bending, but shall not be less than $0.0012 A_c$ on either face.
- (4) The distance between two adjacent vertical bars shall not exceed 200 mm.

16.3.2 Horizontal reinforcement

- (1) Horizontal reinforcement running parallel to the faces of the wall should be provided and arranged at each surface between the vertical reinforcement and the nearest surface. The area of total horizontal reinforcement should not be less than 25 percent of the area of total vertical reinforcement or $0.001A_c$ whichever is greater.
- (2) The spacing between two adjacent horizontal bars shall not be more than 300 mm.
- (3) The diameter shall not be less than one quarter of that of the largest diameter of vertical bars, nor less than 8 mm.

16.3.3 Transverse reinforcement

If the area of the load carrying vertical reinforcement in two faces exceeds $0.02 A_c$ this reinforcement should be enclosed by stirrups in accordance with Clause 16.2.3 for columns.

16.4 Hollow Piers/Columns

Hollow piers/columns shall satisfy all of the following conditions:

- (1) The largest overall dimension is not greater than four times the smallest overall dimension.
- (2) The height is such that the ratio of effective length to radius of gyration is not less than 12.
- (3) The two ends are capped by solid structural members of sufficient thickness to ensure that for unit as a whole, the plane sections remain plane under action of axial load and bending. A solid reinforced concrete slab, having thickness not less than one-third the size of clear inside dimension of the hollow section in the direction of spanning of the slab and integrally connected to the walls of the hollow pier/column, may be considered to fulfil the requirement.
- (4) The wall thickness shall not be less than 300 mm.

16.4.1 Detailing rules

- (1) For wall type pier of non-circular hollow section with length less than four times the width, the rules for solid columns stipulated in Clause 16.2 will apply.
- (2) For wall type pier of non-circular of hollow section with length more than 4 times the width, the rules as per Clause 16.3 will apply.

16.5 Beams

16.5.1 Longitudinal reinforcement

16.5.1.1 Minimum and maximum reinforcement percentage

- (1) The effective cross-sectional area of the longitudinal tensile reinforcement should be not less than that required to control cracking (Section 12), nor less than $A_{s,min}$ where,

$$A_{s,min} = 0.26 \frac{f_{ctm}}{f_{yk}} b_t d, \text{ but not less than } 0.0013 b_t d \quad \text{Eq. 16.1}$$

Where

b_t denotes the mean width of the tension zone; for a T-beam or L-beam with the flanges in compression, only the width of the web is taken into account in calculating the value of b_t .

f_{ctm} should be determined with respect to the relevant strength class.

- (2) The cross-sectional areas of the tension reinforcement shall not be greater than $0.025A_c$ at sections other than at laps. The total of tension and compression reinforcement shall not exceed $0.04A_c$ at a section.

16.5.1.2 Tensile steel in flanged section

The total amount of tensile reinforcement A_s of a flanged cross-section (e.g. at intermediate supports of continuous T-beam) may be divided approximately equally over the effective width of the flange (Refer Fig. 16.1).

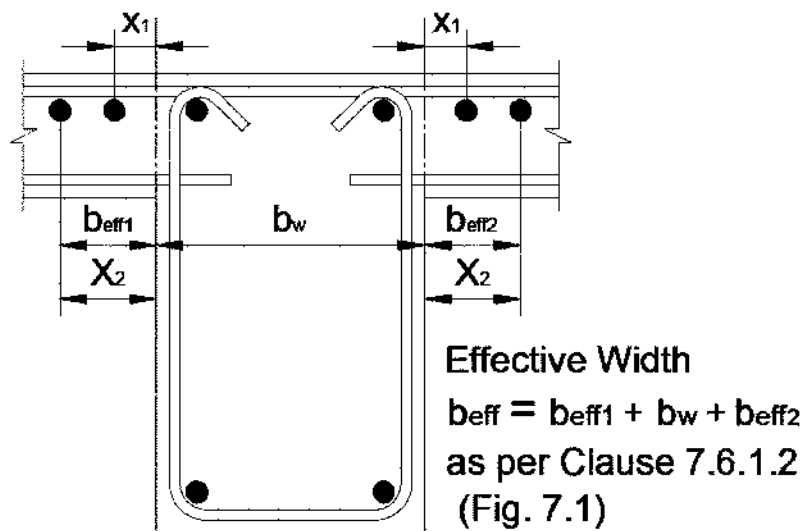

Fig. 16.1 Internal and External Parts of a T-Beam

16.5.1.3 Length of the longitudinal tension reinforcement and anchorage in tension Zone

The curtailment of longitudinal steel and anchorage of the same in tension zone is done as described below with help of **Fig. 16.2**.

- (1) F_s is the tensile force in the longitudinal reinforcement obtained by a cross-section analysis according to Sections 8 & 9 including effect of axial force in member, if any.
- (2) For members with shear reinforcement the additional tensile force in the longitudinal reinforcement due to shear shall be provided in the tensile chord and should be calculated from $\Delta F_{td} = 0.5 \cdot V_{ED} (\cot \theta - \cot \alpha)$.

The total force $\frac{M_{Ed}}{z} + \Delta F_{td}$ should be taken not greater than $\frac{M_{Ed,max}}{z}$ where $M_{Ed,max}$ is the maximum moment along the beam.

In the case of prestressed member the spare capacity in the prestressing cable if available can be used for this requirement.

- (3) For members without shear reinforcement ΔF_{td} may be estimated by shifting the moment curve a distance $a_l = d$ in unfavourable direction according to Clause 10.3.2(6). This 'shift rule' may also be used as an alternative for members with shear reinforcement,

Where

$$a_l = z \left(\frac{\cot \theta - \cot \alpha}{2} \right) \quad \text{Eq. 16.2}$$

where θ is the angle of the concrete strut with the longitudinal axis for the shear reinforcement calculated according to the variable strut inclination method, as per Section 10.

The additional tensile force is illustrated in **Fig. 16.2**.

- (4) The envelope line of the tensile force carried by the longitudinal reinforcement is obtained by a horizontal displacement ' a_l ' of the envelope line of F_s .
- (5) The resistance of bars within their anchorage lengths may be taken into account, assuming a linear variation of force as shown in **Fig. 16.2**. As a simplification this contribution may be ignored.
- (6) For reinforcement in the flange, placed outside the web a_l should be further increased by the distance equal to the distance of the bar from the web. (distance x_1, x_2 in **Fig. 16.1**).
- (7) Curtailed reinforcement should be effectively anchored beyond point where it is no longer required. The anchorage length (l_a) should not be less than larger of distance ' d ' or $l_{b,net}$ where ' d ' is the effective depth of member and $l_{b,net}$ is calculated as per Eq. 15.2 of Section 15.
- (8) The diagram of the resisting tensile forces should lie outside the envelope line of the acting tensile force, displaced as described.
- (9) The anchorage lengths of bent-up bars which contribute to the resistance to shear should be not less than $1.3 l_{b,net}$ when anchored in the tension zone and $0.7 l_{b,net}$ when anchored in the compression zone.

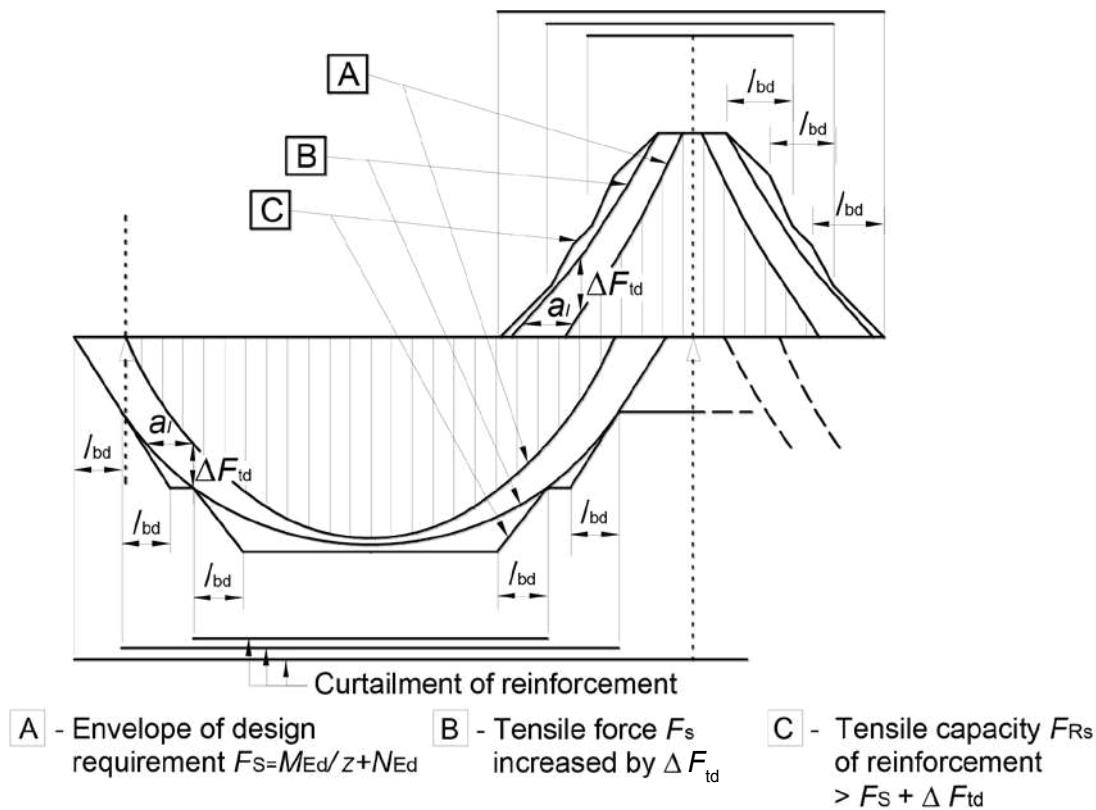

Fig. 16.2 Curtailment of longitudinal reinforcement

16.5.1.4 Anchorage of span reinforcement at an end support

- (1) Over supports with little or no end fixity it is necessary to retain not less than one-quarter of the maximum reinforcement in the span.
- (2) The anchorage of the reinforcement should be capable of resisting a tensile force of:

$$F_s = V_{Ed} \cdot \frac{\alpha_1}{d} + N_{Ed}$$

Eq. 16.3

Where N_{Ed} denotes the design axial force taken by the steel, and V_{Ed} as defined in Section 10, and α_1 as defined in Clause 16.5.1.3. N_{Ed} is taken as positive if it is tensile and negative if it is compressive.

- (3)
 - (a) For a direct support [Refer **Fig. 16.3(a)**] the anchorage length is measured from the line of contact between the beam and its support. It should be minimum as $\frac{2}{3} l_{b,net}$.
 - (b) For an indirect support [Refer **Fig. 16.3(b)**] $l_{b,net}$ is taken from distance $\frac{w}{3}$ from the face of support, where w is total width of the support with $l_{b,net}$ taken according to Eq. 15.2 of Section 15.

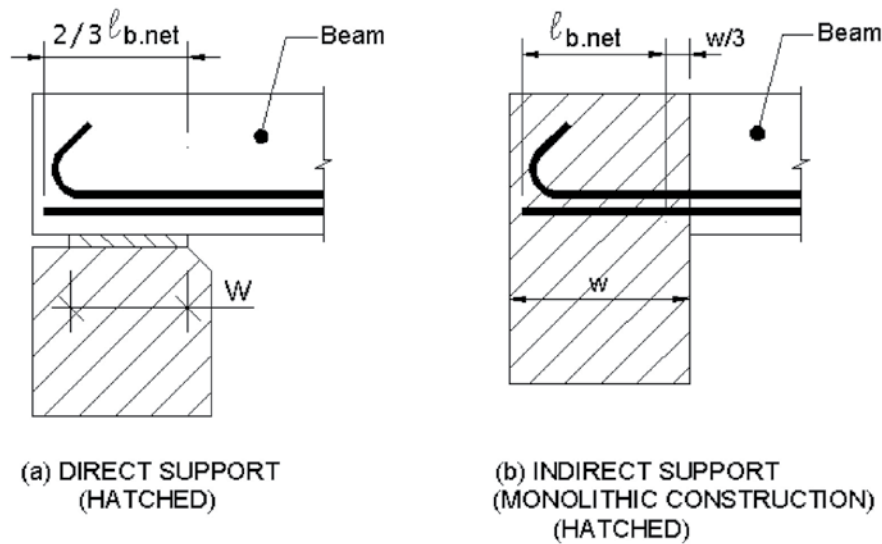

Fig. 16.3 Anchorage End Supports

16.5.1.5 Anchorage of span reinforcement at intermediate supports

- (1) Amount of span reinforcement (steel for sagging moment) carried upto and over intermediate support should not be less than one quarter of steel present in span.
- (2) Anchorage should have a length of not less than 10ϕ for straight bars or not less than the diameter of the mandrel for hooks and bends, as shown in Fig. 16.4.

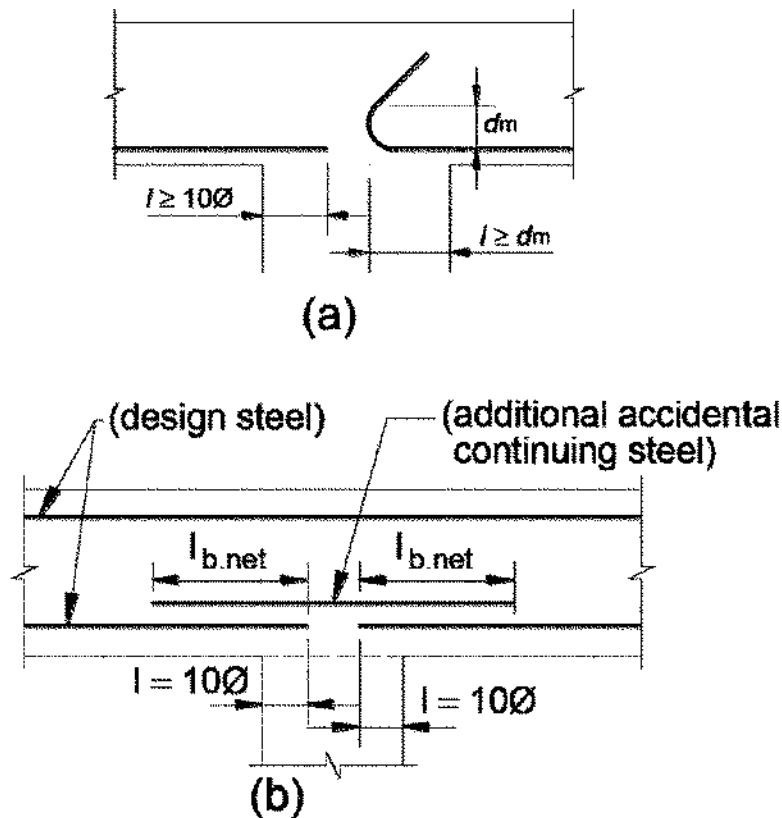

Fig. 16.4 Anchorage at Intermediate Supports

16.5.2 *Shear reinforcement*

- (1) The shear reinforcement should form an angle of 45° to 90° with the longitudinal axis of the structural element.
- (2) The shear reinforcement may consist of a combination of
 - (a) Links enclosing the longitudinal tensile reinforcement as well as the compression zone of concrete,
 - (b) Bent-up bars;
 - (c) Shear assemblies in the form of cages, ladders etc. of HYSD bars which do not enclose the longitudinal reinforcement, but are properly anchored both in the compression and tension zones.
- (3) At least 50 percent of the necessary shear reinforcement should be in the form of links.
- (4) Links should be effectively anchored. A lap joint may be allowed in web only for high yield strength deformed bars.
- (5) The shear reinforcement ratio is given by Eq. 16.4

$$\rho_w = \frac{A_{sw}}{(s \cdot b_w \cdot \sin \alpha)}$$

Eq. 16.4

The minimum value $\rho_{w,\min}$ for ρ_w is as given by:

$$\rho_{w,\min} = \frac{(0.072 \sqrt{f_{ck}})}{f_{yk}}$$

Eq. 16.5

In above equations:

- ρ_w = is the shear reinforcement ratio.
- A_{sw} = is the area of shear reinforcement within lengths.
- s = is the spacing of the shear reinforcement, measured along longitudinal axis of the member.
- b_w = is the minimum breadth of the web of the member.
- α = is the angle between the shear reinforcement and the longitudinal axis (i.e. for vertical stirrups $\alpha = 90^\circ$ and $\sin \alpha = 1$).

- (6) The minimum clear distance between vertical legs of shear reinforcement should be largest of :
 - $d_g + 10$ mm
 - 40 mm
 - 2ϕ of shear Reinforcement.

- (7) The maximum longitudinal spacing $s_{l,\max}$ of successive series of stirrups or shear assemblies should not exceed $s_{l,\max}$, where,

$$s_{l,\max} = 0.75d (1 + \cot \alpha)$$

Eq. 16.6

- (8) The maximum longitudinal spacing of bent-up bars should not exceed $s_{b,\max}$ where,

$$s_{b,max} = 0.6 d (1 + \cot \alpha) \quad \text{Eq. 16.7}$$

(9) The transverse spacing of the legs in a series of shear links should not exceed:

$$s_{t,max} = 0.75d \leq 600 \text{ mm} \quad \text{Eq. 16.8}$$

16.5.3 *Torsional reinforcement*

- (1) The torsion links should consist of fully closed loops formed by lapping straight portions which have bents or hooks at free ends. The links should form an angle of 90° with the axis of the structural element.
- (2) The provisions of Clause 16.5.2 (5) and (7) are generally sufficient to provide the minimum torsion links required.
- (3) The longitudinal bars should be so arranged that there is at least one bar at each corner, the others being distributed uniformly around the inner periphery of the links, spaced at not more than 350 mm centres.
- (4) The longitudinal spacing of the torsion links should not exceed $1/8^{\text{th}}$ of the outer perimeter of the member.
- (5) The spacing in (4) above should also satisfy the requirements in Clause 16.5.2 (7) for maximum spacing of links.

16.5.4 *Surface reinforcement*

- (1) In certain cases, (e.g. clear cover to main reinforcement being larger than 75 mm and in webs) it may be necessary to provide surface reinforcement, either to control cracking or to ensure adequate resistance to spalling of the cover.
- (2) Surface reinforcement to control cracking in webs should normally be provided in beams over 1 m deep. It should be provided in two directions, parallel and orthogonal to main tension reinforcement in the beam. The maximum spacing of bars shall be 200 mm. The reinforcement already provided from other considerations can be taken into account to cover this requirement.
- (3) The requirements of minimum cover needed for reinforcing bars also apply to surface reinforcement.
- (4) The area of surface reinforcement $A_{s,sur}$ should be not less than $0.01 A_{ct,ext}$ where $A_{ct,ext}$ is the area of cover portion outside the stirrups/links.
- (5) The longitudinal bars of the surface reinforcement may be taken into account as a part of longitudinal bending reinforcement and the transverse bars as a part of shear reinforcement provided that they meet the requirements for the arrangement and anchorage of these types of reinforcement.
- (6) Any surface reinforcement in prestressed beams can be taken into account while calculating surface steel as required by (4) above.

16.6 **Solid Slabs**

This Clause applies to two-way and one-way solid slabs, where effective span to thickness ratio is equal to or greater than 5 in both directions for two-way slabs and in the direction of span for one-way slab.

16.6.1 Flexural reinforcement

16.6.1.1 General

- (1) For curtailment of the main reinforcement, clauses for beam given in Clause 16.5.1.3 apply.
- (2) The minimum and maximum steel percentages in the main direction should be as for beam given in Clause 16.5.1.1.
- (3) Secondary transverse reinforcement should be provided in one-way slab. This should be at least 20 percent of the main reinforcement.
- (4) The maximum spacing of the bars for structural purposes is as follows where 'h' denotes the total depth of the slab:
 - For the principal reinforcement in one-way slab and reinforcement in both directions in two-way slab : S_{max} shall be lesser of 2h or 250 mm.
 - For secondary reinforcement in one way slab S_{max} shall be lesser of 3 h or 400 mm.
- (5) For slabs provided with shear reinforcement, additional force in the main longitudinal reinforcement as per Clause 16.5.1.3 shall be considered, taking a_e = effective depth.
- (6) Rules as per Clause 16.5.1.3 also apply to slabs.
- (7) Where the principal reinforcement in a slab which is considered as the flange of a T-beam or L-beam is parallel to the beam, transverse reinforcement shall be provided at the top of the flange. This reinforcement shall not be less than sixty percent of the main reinforcement of the slab at its mid-span unless it is specially calculated. The length of such reinforcing bars shall be as indicated in **Fig. 16.5**.

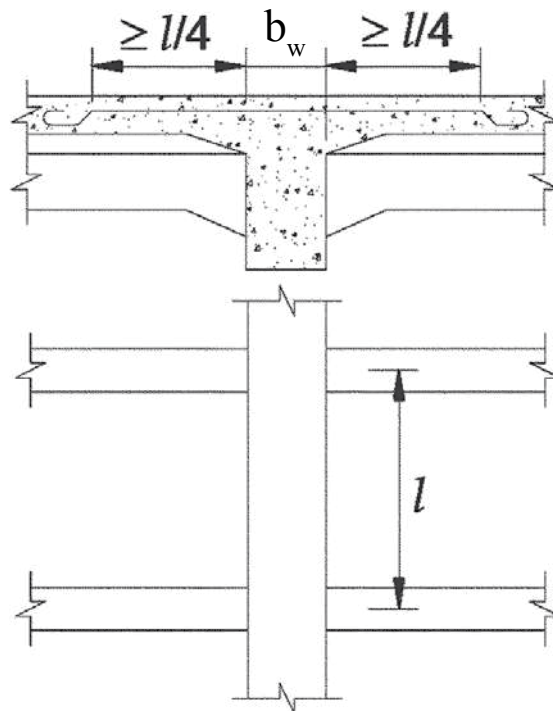

Fig. 16.5 Provision of Reinforcing Bars

16.6.1.2 Anchorage of bottom main steel at intermediate supports

The anchorage should have a minimum length of 10ϕ for straight bars or not less than the diameter of mandrel for hooks and bends. Refer **Fig. 16.3**.

16.6.1.3 Reinforcement in slabs near end supports

- (1) In slabs, half the calculated span reinforcement should continue up to the support and be anchored therein. For end supports, rule given in Clause 16.5.1.4 applies for measuring anchorage length.
- (2) The anchorage of reinforcement should be capable of resisting a tensile force:

$$F_s = V_{Ed} \cdot \frac{\alpha_l}{d} + N_{sd}$$

Eq. 16.9

where

N_{sd} is the axial tensile force in the slab

d is effective depth of slab and

α_l is as defined in Clause 16.5.1.3.

- (3) Where partial fixity occurs along one side of slab, but is not taken into account in the analysis, the top reinforcement should be capable of resisting not less than 25 percent of the maximum moment in the span. This reinforcement should be provided for length of not less than 0.2 times the adjacent span measured from the inner face of the support.

16.6.1.4 Reinforcement at the free edges

- (1) Stiffening of unsupported edge

Unsupported slabs carrying vehicular live load (or accidental wheel load) shall be suitably stiffened as indicated below:

- (a) Each unsupported edge of a slab parallel to traffic and beyond the clear road width, shall be so stiffened as to give a resisting moment for any type of flexure equal to or in excess of that of a 500 mm strip of the main roadway slab adjoining the edge. In case of a roadway slab of uniform depth, whether the reinforcement is one-way (parallel to or across the traffic) or two-way, the maximum resisting moment of the roadway slab adjoining the edge and given by a 500 mm strip in any direction shall be taken as the criterion for the resisting moment of the stiffened edge. When the roadway slab is of varying depth in the direction parallel to the edge concerned, the stiffening at any particular point along the length of edge shall be adjusted according to the resisting moment of the 500 mm adjacent strip at that particular point.

Stiffening of edge may consist of a reinforced kerb section, or an edge stiffening beam. Where concrete crash barriers are provided over the full length of free edge, they may be considered as stiffening beams.

- (b) Unsupported edge along a line across the traffic of a roadway slab (as at the cantilever end of a solid slab cantilever bridge) shall be suitably stiffened for a strip of at least 500 mm width by providing top and bottom reinforcement across the direction of traffic in addition to that required for articulation and local strengthening for expansion

joint, if any. In this strip, the top and bottom reinforcement each shall not be less than the average area of longitudinal reinforcement for 500 mm width at the end of the cantilever.

- (2) For other cases where end stiffening is not required to carry traffic across, detailing shall be as follows:
- Along a free (unsupported) edge, a slab should normally contain longitudinal and transverse reinforcement generally arranged as shown in **Fig. 16.6**.
 - The normal reinforcement provided for a slab may be detailed in such a way as to act as edge reinforcement.

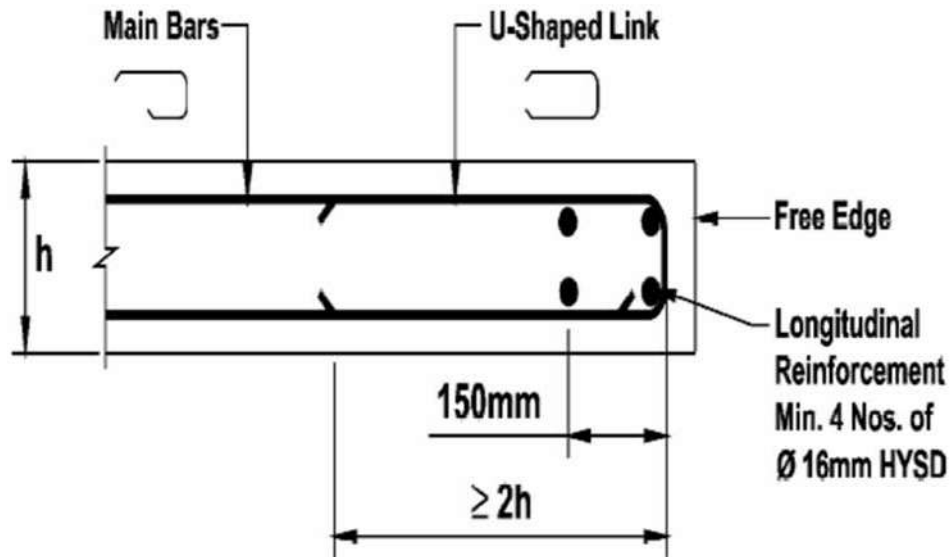

Fig. 16.6 Edge Reinforcement for Slab

16.6.1.5 Corner reinforcement

If the detailing arrangements at a support are such that lifting of the slab at a corner is restrained, suitable reinforcement should be provided.

16.6.2 Shear reinforcement

- A slab in which shear reinforcement is provided should have a depth of at least 200 mm.
- In detailing the shear reinforcement, Clause 16.5.2 applies except where modified by the following rules.
- In slabs if $V_{Ed} \leq \frac{1}{3}V_{Rd,max}$. (Refer Section 12), the shear reinforcement may consist entirely of bent-up bars or of shear assemblies.
- The maximum longitudinal spacing of bent-up bars is $S_{max} = d$.
- The maximum longitudinal spacing of successive series of links is given by :

$$S_{max} = 0.75d (1 + \cot \alpha)$$

Eq. 16.10

where α is inclination of shear reinforcement.

16.7 Corbels**16.7.1 General**

- (1) Corbels may be designed by using strut and tie model. The inclination of strut with respect to the “main” tie should lie between 45° and 68° . The strut shall be dimensioned such that the concrete compression stress does not exceed that given in clause 6.4.2.8. Horizontal forces, H_{Ed} when applied in addition to the vertical load F_{Ed} , will require additional reinforcement in the tie. The effects of torsion, if any, have to be catered to in accordance with clause 10.5.2.1.
- (2) The reinforcement, corresponding to the ties designed using strut and tie model should be fully anchored beyond the node under the bearing plate, by using U-hoops or anchorage devices such as welding to a cross bar, unless a length $l_{b,net}$ is available between the node and the front of the corbel. $l_{b,net}$ should be measured beyond the full width of compressive strut. It shall be fully anchored at the other end in the body of the member to which the bracket is attached.
- (3) In corbels where $a_c \leq 0.5 h_c$ closed horizontal or inclined links with area $A_{s,link}$ shall be provided in addition to the main tension reinforcement as shown in **Fig. 16.7(a)** or **Fig. 16.7(c)**, where:

$$A_{s,link} > 0.50 A_{s,main} \text{ (to be provided in upper two-third of the corbel depth)} \quad \text{Eq. 16.11}$$

- (4) In corbels where a_c lies between $0.5 h_c$ and h_c and $F_{Ed} > V_{Rd,c}$ (Refer clause 10.3.2 and 10.3.3), closed vertical stirrups with area $A_{s,stirrup}$ shall be provided in addition to the main tension reinforcement and the closed horizontal or inclined links, as shown in **Fig. 16.7(b)**, where:

$$A_{s,stirrup} \geq 0.5 F_{Ed} / f_{yd} \quad \text{Eq. 16.12}$$

In addition check against crushing of strut shall be made in accordance with Eq. 10.5

- (5) If $a_c > h_c$ the design shall be carried out as a flexural member. The shear check shall be carried out as per Eq. 10.5 of 10.3.2 (5) for checking against crushing of concrete as well as 10.3.3.3(7) and 10.3.3.3(8) for arriving at the shear reinforcement.
- (6) The bearing area on a corbel shall not project either beyond the straight portion of the main tension bars or beyond the interior face of any transverse anchor bar.
- (7) In the case of corbels with varying depth, Fig. 16.7(c), the depth at the outside edge of the bearing area shall not be less than half the depth at the face of the support. The favourable contributions from inclined compression chord and tensile chord (clause 10.2.3) shall not be considered.

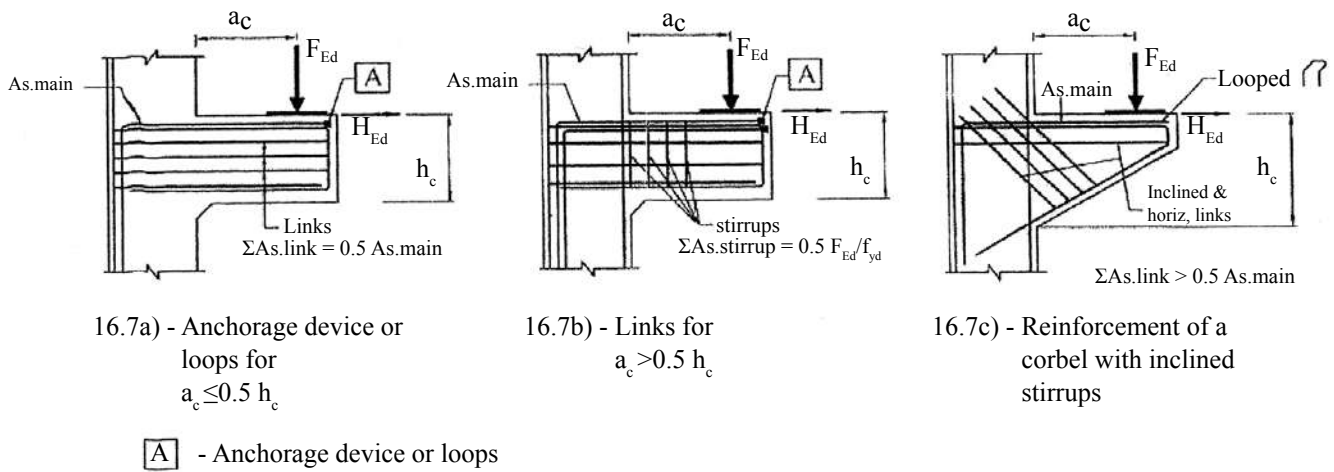

Note: Provide chamfer to avoid re-entrant corners for corbels as in 16.7(a), 16.7(b) and 16.7(c)

Fig. 16.7 Reinforcement of a Corbel

16.8 Articulations

- (1) The articulation acts analogously to the corbels, except that the local bearing load is distributed to full section by inclined tensile steel.
- (2) The general shape and arrangement of reinforcement shall be as shown in **Fig. 16.8**. The design of bearings at articulations shall ensure that concentrated edge stresses will not be induced and the angular rotation of the cantilevers and the suspended span is possible without any damage to the articulation.

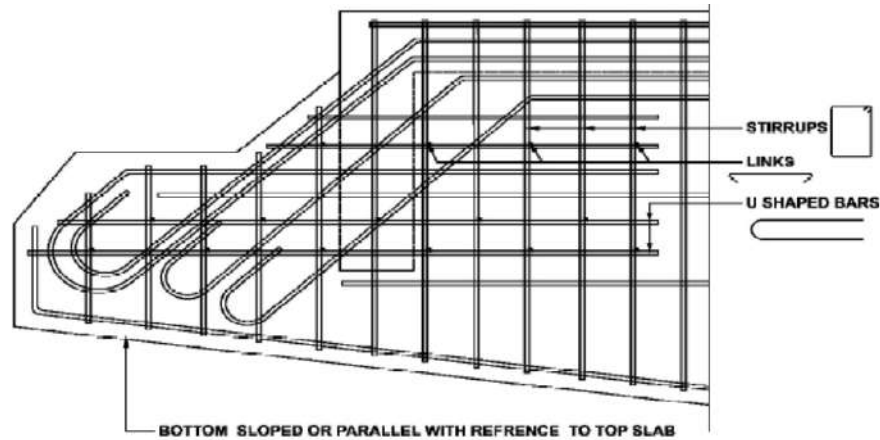

Fig. 16.8 Articulation – General Shape and Arrangement of Reinforcement

16.9 Deep Beams

- (1) Deep beams (span/depth ratio less than 3) can be designed using appropriate elastic models or by plastic methods.
- (2) Generally, detailing rules for anchorages and laps given in Section 15 apply to the design of reinforcement.
- (3) The reinforcement corresponding to the ties, designed using strut and tie model, should be fully anchored beyond the nodes by bending up the bars, by using U hoops or by anchorage

devices unless a sufficient length is available between the node and the end of the beam permitting an anchorage length of $l_{b.net}$.

- (4) Deep beams should normally be provided with a distributed reinforcement on both sides, the effect of each being equivalent to that of an orthogonal mesh with a reinforcement ratio of at least 0.15 percent in both directions, but not less than 150 mm² per metre in each face and in each direction. The spacing shall not exceed 200 mm.

16.10 Members with Unbonded Tendons

For members with only unbonded tendons, requirements for reinforced concrete elements apply.

For members with a combination of bonded and unbonded tendons, requirements for prestressed concrete members with bonded tendons apply.

Crack width may be calculated according to Clause 12.3.4 and Clause 12.3.5. Alternatively, limiting maximum bar size or spacing as per Clause 12.3.6 may be deemed to satisfy crack control criteria for reinforced concrete members.

16.11 Concentrated Forces

16.11.1 General

- (1) Where one or more concentrated forces act at the end of a member or at the intersection of two structural members, local supplementary reinforcement should be provided capable of resisting the transverse tensile forces caused by these forces.
- (2) This supplementary reinforcement may consist of links or of layers of reinforcement bent in the shape of hair pins.
- (3) For uniform distribution of load on area A_{CO} , (**Fig. 16.9**), the concentrated resistance force can be determined as follows:

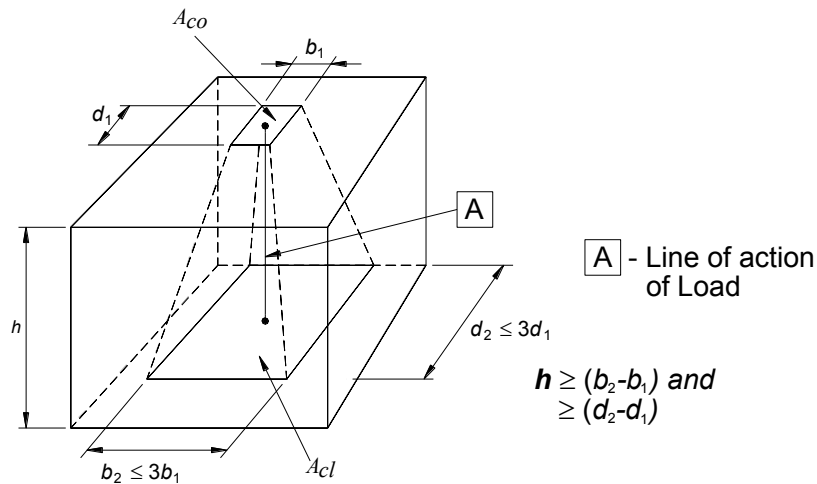

Fig. 16.9 Design Distribution for Partially Loaded Areas

$$F_{Rdu} = A_{co} f_{cd} \sqrt{\frac{A_{cl}}{A_{co}}} \leq 3 f_{cd} A_{co}$$

Eq. 16.13

Where

$$f_{cd} = \alpha f_{ck} / \gamma_c \quad \text{for concrete grade} < \text{M60}$$

A_{co} denotes the loaded area.

A_{cl} denotes the maximum design distribution area at distance h with a similar shape to A_{co} having the same centre of area, which it is possible to inscribe in the total area A_c situated in the same plane as that of A_{cl} . The distance h satisfies conditions given in the figure.

The value of F_{Rdu} obtained from Eq. 16.13 should be reduced if the load is not uniformly distributed on area A_{co} .

- (4) For concrete grade equal to or higher than M60, in Eq.16.13, f_{cd} should be substituted by

$$f_{cd} = \frac{0.396 f_{ck}^{2/3}}{1 + .08 f_{ck}} \left(\frac{\alpha f_{ck}}{\gamma_c} \right)$$

Eq. 16.14

- (5) If the axial load is accompanied by large shear forces, three dimensional finite element analyses may be carried out using appropriate elements and mesh size and the relevant material properties.
- (6) Where prestressing anchorages are placed, bearing on external surface, manufacturer's recommendation should be followed, as per Section 13.

16.11.2 Zones below bearings

- (1) The design of bearing zones of bridges should be in accordance with the rules given in this clause in addition to those in Clause 16.11.1.
- (2) The distance from the edge of the loaded area to the free edge of the concrete section should not be less than 1/6 of the corresponding dimension of the loaded area measured in the same direction. In no case should the distance to the free edge be less than 50 mm.
- (3) In order to avoid edge sliding, uniformly distributed reinforcement parallel to the loaded face should be provided to the point at which local compressive stresses are dispersed. This point is determined as follows:

A line inclined at an angle θ (30°) to the direction of load application is drawn from the edge of the section to intersect with the opposite edge of the loaded surface, as shown in **Fig. 16.10**. The reinforcement provided to avoid edge sliding (A_s) shall be calculated using the expression $A_s \cdot f_{yd} \geq \frac{F_{Rdu}}{2}$ and shall be adequately anchored on both sides of the failure plane. Reinforcement provided for other purposes may also be utilized for this requirement.

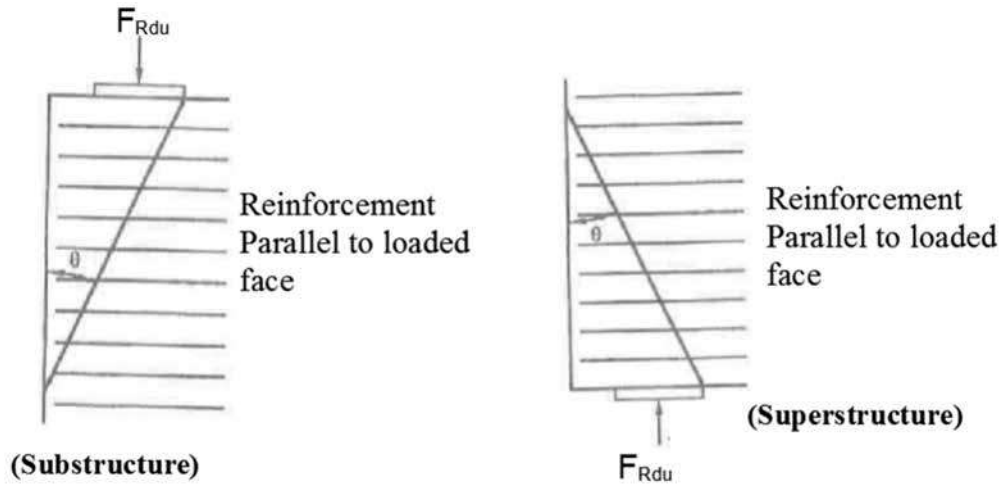

Fig. 16.10 Edge Sliding Mechanism

16.12 Forces Associated with Change in Direction

At points where considerable changes in the direction of the internal forces occur in concrete, reinforcing steel or prestressing steel, the associated forces in direction normal to the same shall be resisted by means of suitably anchored additional reinforcement. Refer Clause 7.10.1 for requirements of curved tendons.

16.13 Indirect Supports

- (1) In the case of a connection between a supporting beam and a supported beam, ‘suspension’ reinforcement designed to resist the total reaction from supported beam, shall be provided in addition to shear reinforcement.
- (2) The suspension reinforcement should consist preferably of links surrounding the principal reinforcement of the supporting member. Some of these links may be distributed outside the volume of concrete which is common to the two beams, as indicated in Fig. 16.11.

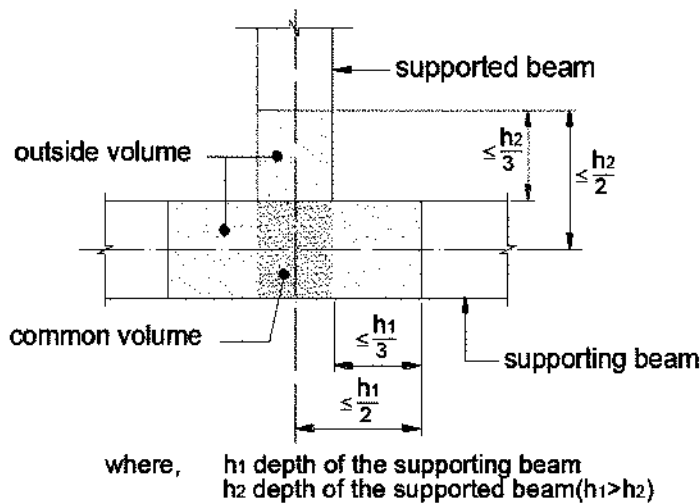

Fig. 16.11 Extent of the Inter-Section Zone (in Plan) for the Connection of Secondary Beams

16.14 Anchorage Zones for Post Tensioning Forces

Anchorage zone is defined as the zone within which the concentrated forces of post tensioned anchorages disperse and spread over the full section of the prestressed structural element.

For the design and amount of reinforcement for the full section and for the local effects, refer Section 13. This reinforcement should be detailed to meet requirements of Clause 13.5 as well as to satisfy the following rules. Extra reinforcement over and above the calculated amount as per Clause 13.5 shall be provided, if needed, to satisfy these rules.

- (1) Anchorage zones should always be provided with distributed reinforcement near all surfaces in the form of an orthogonal mesh.
 - (2) Where groups of post-tensioned cables are located at a certain distance from each other, suitable links should be arranged at the ends of the members, as a protection against splitting away of groups.
 - (3) All reinforcement should be fully anchored.
 - (4) Where a strut and tie model has been used to determine the transverse tensile force, the following detailing rules shall be followed:
 - (a) The steel area actually required to provide the tie force, acting at its design strength, shall be distributed in accordance with the actual tensile stress distribution, i.e. over a length of the block approximately equal to its greatest lateral dimension.
 - (b) Closed stirrups should be used for anchorage of ties.
-

SECTION 17

DUCTILE DETAILING FOR SEISMIC RESISTANCE

17.1 General

- (1) Ductile detailing shall be carried out for bridges located in zones III, IV and V of seismic zone map of IRC:6, if they are designed for Response reduction factor $R > 1.0$
- (2) The rules of this Section apply to bridges designed for ductile behaviour for improving their seismic resistance and aim to ensure a minimum level of curvature/rotation ductility at the plastic hinges. These are supplementary to the rules given in Sections 15 & 16 which remain applicable, unless specifically modified in this Section.
- (3) In general, plastic hinge formation is not allowed in the superstructure. Therefore there is no need for application of detailing rules of this Section for the superstructure.
- (4) Bridge foundation system shall be designed, as far as practicable, to remain elastic under design seismic action and foundations shall not be intentionally used as a means of energy dissipation through phenomenon of hysteresis.
- (5) The bridge shall be proportioned and detailed in such a manner that plastic hinges can occur only at pre-determined locations and not at any other locations.
- (6) Where longitudinal reinforcement is curtailed potential of formation of hinge shall be avoided just beyond the point of curtailment. Not more than 1/3 of longitudinal reinforcement available at the section shall be curtailed.

17.2 Concrete Piers/Columns

17.2.1 Confinement

17.2.1.1 General requirements

- (1) Within the potential plastic hinge regions, ductile behaviour of the compression zone of concrete shall be ensured by providing confinement of concrete.
- (2) Confinement is implemented through rectangular hoops and/or cross-ties or through circular hoops or spirals.
- (3) In potential hinge regions where the normalised axial force η_k exceeds the limit,

$$n_k = \frac{N_{ED}}{A_c f_{ck}} > 0.064, \quad \text{Eq. 17.1}$$

confinement of the compression zone in accordance with Clause 17.2.1.4 shall be provided.

- (4) The required quantity of confining reinforcement expressed as ratio ω_{wd} is calculated as per Eq. 17.2 and shall satisfy the requirements of Clause 17.2.1.2:

$$\omega_{wd} = \frac{\rho_w \cdot f_{yd}}{f_{cd}} \quad \text{Eq. 17.2}$$

where

- (a) In rectangular sections:

ρ_w is the volumetric ratio of transverse reinforcement defined as:

$$\rho_w = \frac{A_{sw}}{S_L \cdot b} \quad \text{Eq. 17.3}$$

where

A_{sw} = is the area of the stirrups and ties in one direction of confinement.

S_L = is the spacing of hoops or ties in the longitudinal direction

b = is the dimension of the concrete core perpendicular to the direction of the confinement under consideration, measured to the outside of the perimeter hoop.

(b) In circular sections:

Volumetric ratio ρ_w of the hoops/spiral reinforcement relative to the concrete core is given by Eq. 17.4:

$$\rho_w = \frac{4A_{sp}}{D_{sp} \cdot S_L} \quad \text{Eq. 17.4}$$

where

A_{sp} is the area of the spiral or hoop bar

D_{sp} is the diameter of the spiral or hoop

S_L is the spacing of these bars

Note: Bars inclined at an angle α to the transverse direction shall be assumed to contribute to the total area A_{sw} or A_{sp} in Eq. 17.3 by their area multiplied by $(\cos \alpha)$

17.2.1.2 Minimum confining reinforcement

(1) Confinement is provided by use of rectangular loops and/or cross ties for rectangular sections or through circular hoops or spirals for circular sections.

(2) For rectangular stirrups and cross-ties, the minimum design confining reinforcement is the greater of two values given in Eq.17.5.

The minimum reinforcement condition shall be satisfied in both directions.

$$\omega_{wd} = \max \left[\omega_{w.req}; 0.12 \right] \quad \text{Eq. 17.5}$$

$$\omega_{w.req} = 0.37 \frac{A_c}{A_{cc}} \eta_k + 0.13 \frac{f_{yd}}{f_{cd}} (\rho_L - 0.01) \quad \text{Eq. 17.6}$$

where

A_c is the area of the gross concrete section;

A_{cc} is the confined (core) concrete area of the section within the outside dia of hoop.

η_k Normalised axial force (Clause 17.2.1.1);

ρ_L is the reinforcement ratio of the longitudinal reinforcement.

(3) Interlocking spirals/hoops are quite efficient for confining approximately rectangular sections. The distance between the centres of interlocking spirals/hoops shall not exceed $0.6D_{sp}$ where D_{sp} is the diameter of the spiral/hoop (Refer **Fig. 17.1**).

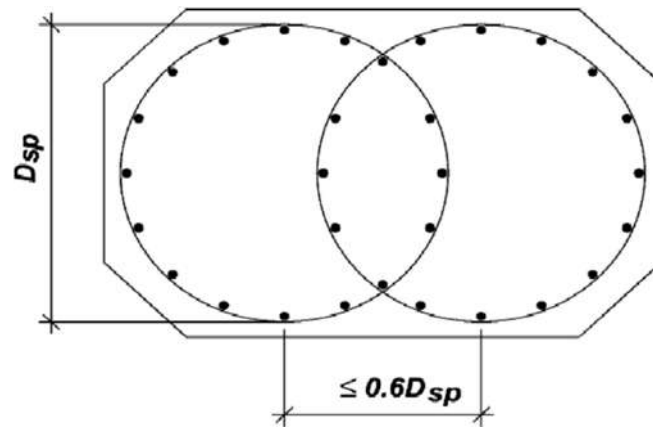

Fig. 17.1 Typical Confinement Detail in Concrete Piers Using Interlocking Spirals/Hoops

- (4) For circular sections, the minimum confining reinforcement provided by hoops/spiral is determined as the higher of two values given in Eq. 17.7

$$\omega_{wd,c} \geq \max(1.4\omega_{w,req}; 0.18) \quad \text{Eq. 17.7}$$

- (5) When rectangular hoops and cross-ties are used, the minimum reinforcement condition shall be satisfied in both transverse directions

17.2.1.3 Spacing of ties/hoops/spirals

- (1) The spacing of hoops or ties in the longitudinal direction, S_L shall satisfy both of the following conditions:

$S_L \leq 5$ times the diameter of smallest longitudinal bar.

$S_L \leq 1/5$ of the smallest dimension of confined concrete core for rectangular section or 1/5th of the diameter of confined core of concrete for circular section, both measured upto hoop centre line.

- (2) For rectangular section, the transverse distance s_T between hoop legs or supplementary cross-ties, shall not exceed 1/3 of the smallest dimension of the concrete core or 200 mm whichever is less (Refer **Fig. 17.2**).

17.2.1.4 Extent of Confinement - Length of Potential Plastic Hinges

- (1) When $n_k = \frac{N_{ED}}{A_c f_{ck}} \leq 0.24$ the design length L_h of potential plastic hinges shall be estimated as the larger of the following two values:

- the depth of the pier section within the plane of bending (perpendicular to the axis of rotation of the hinge);
- the distance from the point of maximum design moment to the point where the design moment is 80 percent of the value of the maximum moment.

- (2) When $0.48 \geq \eta_k > 0.24$ the design length of the potential plastic hinges as determined in (1) shall be increased by 50 percent.

- (3) The design length of plastic hinges (L_h) estimated above should be used exclusively for detailing the reinforcement of the plastic hinge. It should not be used for estimating the

plastic hinge rotation.

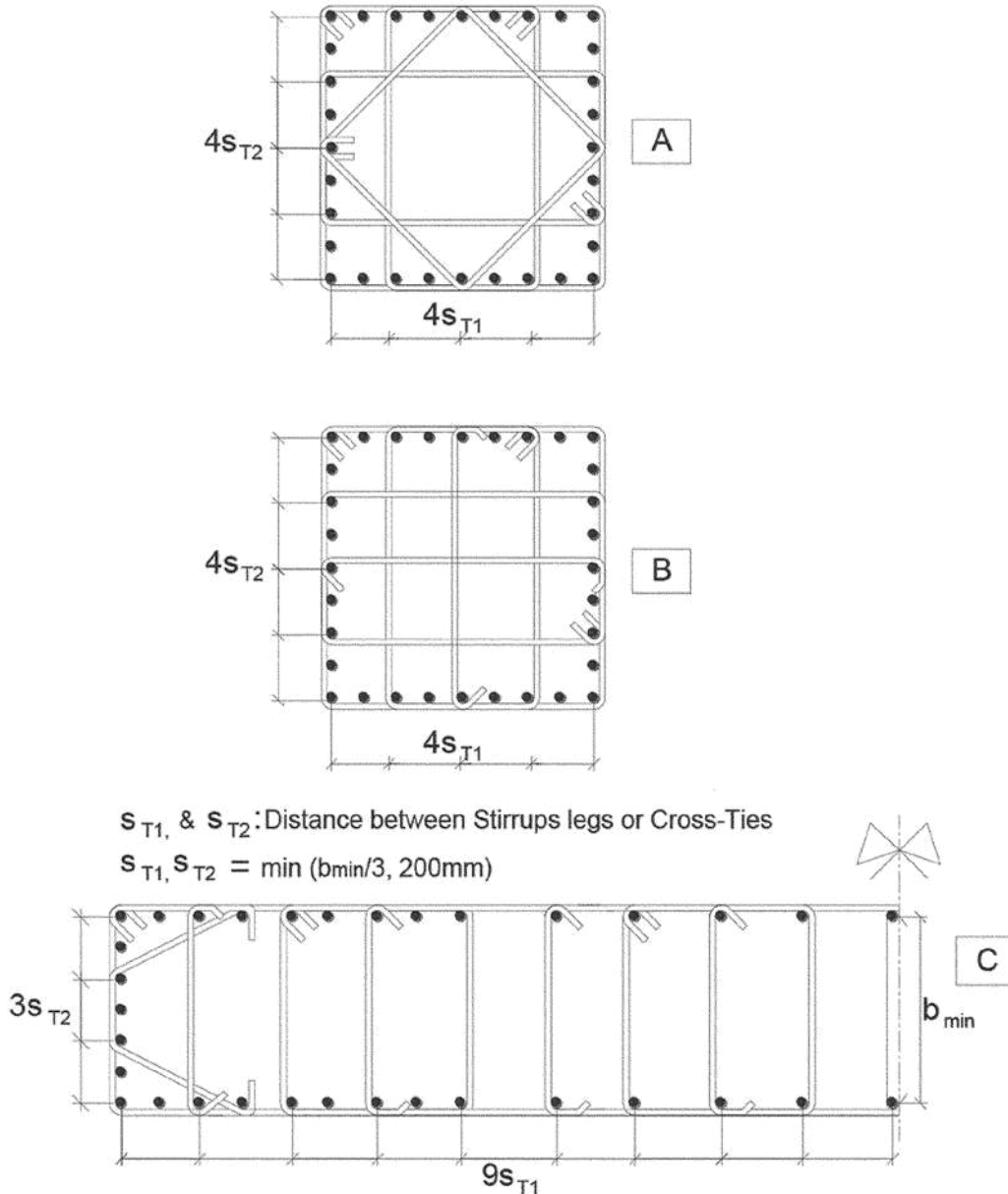

- A: 4 closed overlapping stirrups
- B: 3 closed overlapping stirrups plus cross-ties
- C: closed overlapping stirrups plus cross-ties

Fig. 17.2 Typical Confinement Details in Concrete Piers with Rectangular Section using Overlapping Rectangular Stirrups and Cross-Ties

- (4) When confinement is required, the reinforcement specified in Clause 17.2.1.2 shall be provided over the entire length of the plastic hinge. Outside the length of the hinge, the transverse reinforcement may be gradually reduced to that required by other criteria. The amount of transverse reinforcement provided over an additional length L_h adjacent to the theoretical end of the plastic hinge, shall not be less than 50 percent of the confining reinforcement required in the region of plastic hinge.

- (5) The confinement shall extend at least upto the length where the value of the compressive strain exceeds $0.5 \varepsilon_{cu2}$.

17.2.2 *Buckling of longitudinal compression reinforcement*

- (1) Buckling of longitudinal reinforcement shall be avoided along the length of the potential hinge areas, even after several hysteresis cycles in post-yield region of stress-strain diagram of steel.

To meet this requirement all main longitudinal bars should be restrained against outward buckling by transverse reinforcement (hoops or crossties for rectangular section and though circular hoops or spirals for circular section) perpendicular to the longitudinal bars at a (longitudinal) spacing S_L not exceeding five times d_{bL} , the diameter of the smallest longitudinal bars.

- (2) Along straight section boundaries, restraining of longitudinal bars should be achieved in either one of the following ways:

- (a) Through a perimeter tie engaged by intermediate cross-ties at alternate locations of longitudinal bars, at transverse (horizontal) spacing S_t not exceeding 200 mm. The cross-ties shall have 135° hooks at one end, and 135° or 90° bend at the other end. Bends of 90° are not permitted if η_k is greater than 0.24. Cross ties having 135° on both ends may consist of two lapped spliced pieces. In sections of large dimensions the perimeter tie may be spliced using appropriate lapping length combined with hooks; or
- (b) Through overlapping closed ties arranged so that every corner bar and at least every alternate internal longitudinal bar is engaged by a tie leg. The transverse (horizontal) spacing of the tie legs should not exceed 200 mm.
- (c) The minimum amount of transverse ties shall be determined as follows:

$$\left\{ \frac{A_t}{S_L} \right\} = \frac{\sum A_s f_{ys}}{1.6 f_{yt}} \text{ (mm}^2\text{/m)}$$

Eq. 17.8

where

A_t is the area of one tie leg, in mm².

S_L is the spacing of the legs along the axis of the member, in m;

$\sum A_s$ is the sum of the areas of the longitudinal bars in outer layer restrained by tie at any one end, in mm²;

f_{yt} is the yield strength of the tie; and

f_{ys} is the yield strength of the longitudinal reinforcement.

- (d) The steel A_s shall be determined for different situations for A_t as follows:

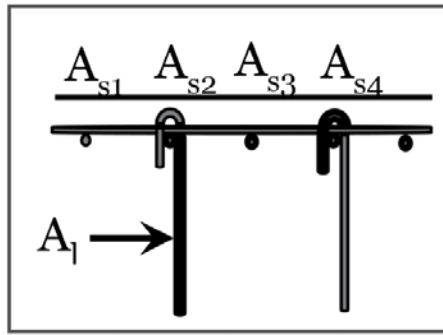

A_s for determining $A_1 = 0.5 A_{s1} + A_{s2} + 0.5 A_{s3}$

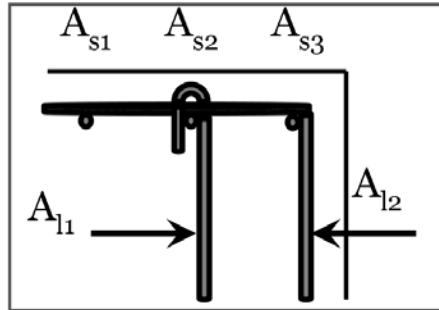

A_s for determining $A_{l1} = 0.5 A_{s1} + A_{s2}$

$A_{l2} = A_{s3}$

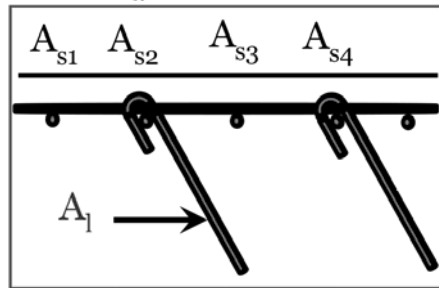

When A_1 is at any inclination to the transverse outer tie, then the A_s shall be divided by the Sine of the angle between the outer transverse tie and this tie, e.g. in case A_1 is inclined at 45 degrees to the outer tie, then A_s shall be divided by $\text{Sin } 45$, hence $A_s = \sqrt{2} \times (0.5 A_{s1} + A_{s2} + 0.5 A_{s3})$

- (3) Along Circular section boundaries, restraining of longitudinal bars should be achieved through circular ties determined by :

$$\frac{A_t}{S_L} = \frac{1}{12.8} \times \rho_l \times D^2 \times \frac{f_{ys}}{f_{yt}} \text{ (mm}^2\text{/m)}$$

Eq. 17.9

where

A_t is the area of one circular tie, in mm^2 .

S_L is the spacing of the circular tie along the axis of the member, in m;

ρ_l is the reinforcement ratio of the longitudinal steel;

D is the Diameter of the Circular section in mm

f_{yt} is the yield strength of the tie; and

f_{ys} is the yield strength of the longitudinal reinforcement.

17.2.3 *Other rules*

- (1) Due to the possibility of loss of concrete cover in the plastic hinge region, the confining reinforcement shall be anchored by 135° hooks around a longitudinal bar. Where 90° bend is used as per Clause 17.2.2(2), the bar shall extend by minimum 10 diameters into the core concrete.
- (2) Similar anchoring or a full strength weld is required for the lapping of spirals or hoops within potential plastic hinge regions. In this case laps of successive spirals or hoops, when located along the perimeter of the member, should be staggered.
- (3) Splicing by lapping or welding of longitudinal reinforcement is not allowed within the plastic hinge region.
- (4) The confinement steel and buckling preventing reinforcement shall not be added together.
- (5) The buckling prevention and confinement steel may be provided through a set of hoops or single leg cross ties. The hoops shall engage the longitudinal bars only, while single leg ties shall engage both the longitudinal bars and the transverse hoops in the manner shown below at the 135 Degree bent hook. Such ties need not comply with cover requirements at such engagement locations.



17.2.4 *Hollow piers*

- (1) The ratio of the clear width b to the thickness h of the walls, in the plastic hinge region (length L_h in accordance with Clause 17.2.1.4) of hollow piers with a single or multiple box cross-section, should not exceed 8.
- (2) For hollow cylindrical piers the ratio of clear inside diameter, to thickness of wall shall not exceed 8.
- (3) In piers with simple or multiple box section and when the value of the ratio η_k does not exceed 0.16, there is no need for verification of the confining reinforcement in accordance with Clause 17.2.1, provided that the requirements of controlling buckling of longitudinal bars given in Clause 17.2.2 are met.

17.3 **Foundations**

17.3.1 *General*

Spread foundations (such as footings, rafts), wells, box-type caissons, etc. shall not enter the plastic range under the design seismic action and hence do not require any special ductile detailing of reinforcement.

17.3.2 *Pile foundations*

- (1) When it is not feasible to avoid localised hinge formation in the piles by designing pier to form hinges earlier (capacity protection method), integrity and ductile behaviour of piles shall be ensured as given below.
 - (2) The following locations along the pile should be treated as potential plastic hinges.
 - (a) At the pile heads adjacent to the pile cap, when the rotation of the pile cap about a horizontal axis transverse to the seismic action is restrained by the large stiffness of the pile group.
 - (b) At location of maximum bending moment in piles taking into account soil-pile interaction, using appropriate stiffnesses of both pile, pile cap and soil.
 - (c) At the interfaces of soil layers with markedly different shear deformability (e.g. change of strata).
 - (3) At location of type 2(a), confining reinforcement of the amount specified in Clause 17.2.1.1 along a vertical length equal to 3 times the pile diameter, shall be provided.
 - (4) Unless a more accurate analysis is made, longitudinal as well as confining reinforcement of the same amount as that required at the pile head, shall be provided over a length of two pile diameters on each side of the point of maximum moment at location of type 2(b) and of each side of the interface at locations of type 2(c).
-

SECTION 18**MATERIALS, QUALITY CONTROL AND WORKMANSHIP****18.1 General**

This Section gives specifications of materials to be used in construction of new concrete bridges and standards to which they should conform. For new construction, the Indian Standards, referred below or any specific international standards governing these materials, shall be the latest revisions thereof. The tables and notes below table given in this Section are reproduced for ready reference from the relevant IS Codes listed in **Annexure A-3**.

For assessment of properties of materials in existing bridges, the standards in force at the time of their construction or the actual standards used for procurement, shall be referred to. The time dependency of properties shall also be taken into account in such cases.

18.2 Untensioned Steel**18.2.1** *Specification and grades*

Reinforcement shall consist of hot rolled, thermo-mechanical or heat-treated rods, de-coiled rods, or cold worked steel conforming to relevant Indian Standards. The main definitive properties and grades are given in **Table 18.1**. Steel conforming to any other international standard may be used provided its strength, elongation, chemical composition and bond in concrete, are not inferior to those of Indian Standards. The grade designations are as adopted by the relevant standards.

The minimum strength, as specified in relevant BIS Standards, which is either the yield strength in case of mild steel or 0.2 percent proof strength in case of high yield steel is notionally taken as the characteristic strength f_{yk} .

18.2.2 *Other characteristics*

Other important characteristics such as bendability (established by bend and re-bend test), weldability (established by equivalent carbon content) and bond characteristics in concrete should be as specified in IS:432 and IS:1786.

The dimensional tolerances and characteristics of ribs for HSD steel should be as per IS:432 and IS:1786.

18.2.3 *Products with improved corrosion resistance*

Reinforcing steel bars with corrosion resistance improved by any of the following methods, can be used as untensioned reinforcement, provided they meet the minimum strength, proof stress and elongation characteristics as specified for untensioned reinforcement.

Table 18.1 Reinforcing Steel

Type of Steel	Grade / Designation	Relevant BIS Standard	Minimum Yield Stress/ 0.2% proof-stress f_{yk}	Minimum Tensile Strength, as % of the actual 0.2% proof stress/ yield stress but not less than	Min. % elongation
Mild Steel	Grade-I	IS:432 (Part-1)-1982	Bars upto & including 20mm dia. = 250 MPa	410 MPa	23
			20mm \leq dia 50mm 240 Mpa	410 MPa	23
High Strength Deformed Steel (HSD Steel)	Fe 415	IS:1786	415 MPa	110% (not less than 485MPa)	14.5
	Fe 415D			112% (not less than 500MPa)	18.0
	Fe 415S			$\geq 125\%$	20.0
	Fe 500	IS:1786	500 MPa	108% (not less than 545MPa)	12.0
	Fe 500D			110% (not less than 565MPa)	16.0
	Fe 500S			$\geq 125\%$	18.0
	Fe 550	IS:1786	550 MPa	106% (not less than 585MPa)	10.0
	Fe 550D			108% (not less than 600MPa)	14.5
Fe 600	IS:1786	600 MPa	106% (not less than 660MPa)	10.0	

Note:

1. Elongation on a gauge length of $5.65\sqrt{A}$, where A is the cross-sectional area of the test piece, when tested in accordance with IS:1608.
2. For seismic zones III, IV & V, HSD steel bars having minimum elongation of 14.5% and conforming to other requirements of IS:1786 shall be used.
3. For seismic zones III, IV and V, HSD steel bars shall possess following properties:
 - a. The actual 0.2% proof strength of steel bars based on tensile test must not exceed their characteristic 0.2% proof strength by more than 20 percent.
 - b. The ratio of the actual ultimate strength to the actual 0.2 percent proof strength/yield strength shall be at least 1.15.

18.2.3.1 Galvanised reinforcement

Galvanising of reinforcing steel is achieved by hot dipping process in which steel reinforcement is dipped in a bath of molten zinc at about 450°C and cooled in a controlled manner. The coating is chromate treated to avoid reaction between zinc and fresh cement paste. The requirements of coating are as per IS 12594-1988. In this process, zinc is chemically bonded with steel surface in layers with varying percentage of zinc contents, from maximum of 100 percent (i.e. free) zinc as the outermost

layer, to a minimum 72-79 percent of zinc as the innermost layer above the base steel. These layers increase the corrosion resistance of steel.

The strength as well as elongation and bond properties are not adversely affected by galvanising.

18.2.3.2 Epoxy-coated reinforcement

Reinforcing bars conforming to IS 1786 can be coated by fusion bonded epoxy conforming to IS 13620-1993.

The fusion-bonded epoxy coating forms a continuous layer (free of holidays) which has high electrical resistance and prevents setting up of corrosion cells between steel and the surrounding electrolytic micro-environment of moist concrete. It also provides physical barrier between steel and the harmful elements from environmental sources, controlling their rate of penetration. On the other hand, the discontinuities in the barrier (holidays) have the tendency to concentrate the corrosion currents in these areas, leading to faster localised corrosion. The overall effect of coating is, however, beneficial in increasing the corrosion resistance of the structure, provided the occurrence of holidays is controlled.

The bond between reinforcement and concrete is lowered by upto 20 percent of the bond without such coating. In detailing of steel, the lap lengths and anchorage lengths shall be increased by 25 percent.

18.2.3.3 Stainless steel reinforcement

Stainless steel reinforcement shall conform to IS:16651.

Properties of stainless steel reinforcement shall not be inferior to those of carbon steel reinforcement of corresponding strength class.

18.3 Prestressing Steel

18.3.1 Specification and grades

Prestressing steel in the form of plain or indented wires, stress-relieved multi-ply strands, or high tensile steel bars, shall conform to standards given in **Table 18.2** subject to the stipulations given in Clause 18.3.2.

Table 18.2 Types of Prestressing Steel

Type	BIS Standard
Plain Cold Drawn Stress-relieved Wire	IS:1785 (Part-I)
Indented hard-drawn stress-relieved wires	IS: 6003
Stress relieved multi-ply strands of normal relaxation	IS: 6006
Stress-relieved multi-ply strands of low relaxation	IS:14268
High Tensile Steel Bars	IS: 2090

18.3.2 *Nomenclature, grade designation, strength, elongation and relaxation*

The following grades of steel having characteristics as mentioned in **Table 18.3** to **18.5**, are permitted for use in bridges designed for normal life.

For other bridges mentioned in Clause 5.8.1 wires/strands having smaller diameters than those given in the Tables, but otherwise meeting the requirements of Indian Standards mentioned therein, can be used.

Table 18.3 Hard Drawn Stress Relieved Wires

	Diameter, mm	Minimum Tensile strength, MPa	Minimum Elongation at fracture, %
Plain Wires	4	1715	3.0
	5	1570	4.0
	7	1470	4.0
	8	1375	4.0
Indented Wires	4	1715	3.0
	5	1570	4.0

Notes:

- (1) Percent elongation is measured on 200 mm gauge length.
- (2) The 1000 hour relaxation tested at initial load of 0.7 UTS at 20°C shall not be more than 5 percent of 0.7 UTS.
- (3) For plain wires of 5 mm, 7 mm and 8 mm, higher minimum strengths of 1715 MPa, 1570 MPa & 1470 MPa respectively, may also be manufactured as per IS:1785 (Part-1).
- (4) For acceptance of test results from a lot, a value calculated as (arithmetic mean minus 0.6 of the range of test results) shall be more than the minimum strength and elongation specified as per IS 1785.
- (5) 0.2 percent proof stress shall not be less than 85 percent of minimum tensile strength.

Table 18.4 Stress Relieved Strands

Class	Designation	Nominal area, mm²	Normal relaxation		Low relaxation	
			Breaking Load, kN	0.2% Proof Load, kN	Breaking Load, kN	0.2% Proof Load, kN
I	11.1 mm 7 ply	70.0	124.54	105.86	120.1	108.00
	12.7 mm 7 ply	92.9	166.18	139.6	160.1	144.1
	15.2 mm 7 ply	139.0	226.86	192.83	240.2	216.2
II	11.1 mm 7 ply	74.2	137.89	117.21	137.9	124.1
	12.7 mm 7 ply	98.8	183.71	156.11	183.7	165.3
	15.2 mm 7 ply	140.0	261.44	222.23	260.7	234.6

Notes:

- (1) Elongation measured just before fracture of any of the constituent wires on gauge length of 600 mm, shall not be less than 3.5 percent.
- (2) The 1000 hour relaxation value shall not be more than 5 percent and 2.5 percent of 0.7 UTS for normal and low relaxation steel respectively, tested at 0.7 UTS and 20°C.

- (3) For acceptance, all samples tested from a batch shall meet requirement of minimum breaking load and proof load as per IS 6006 and IS 14268.

Table 18.5 High Tensile Bars

Sizes in mm	Minimum Specified Tensile Strength	Minimum 0.2% proof strength
10, 12, 16, 20, 22, 25, 28, 32.	980 MPa	80% of specified tensile strength

Notes:

- (1) Elongation at failure shall not be less than 10 percent measured on gauge length of $5.65 \sqrt{A}$ where A is the area of cross-section of steel bar.
- (2) The 1000 hour relaxation when tested at 70 percent of UTS shall not be more than 49 N/mm².
- (3) For acceptance of test results from a lot, a value calculated as arithmetic mean minus 0.6 of the range of test results shall be more than the minimum strength and elongation specified as per IS 2090.
- (4) 0.2 percent proof stress shall not be less than 85 percent of minimum tensile strength.

18.3.3 Other properties*18.3.3.1 Ductility*

The requirements of ductility at fracture are deemed to be satisfied by use of steel having the minimum elongations specified in Clause 18.3.2.

The wires/strands shall pass the bendability test (reverse bending test) as specified in relevant Indian Standards.

18.3.3.2 Tolerance on size/diameter

The relevant Indian Standards specify the manufacturing tolerances on diameters/size of various products, which remain valid for general acceptance of the material and for qualifying the source of supply.

18.3.4 Coated wires/strands

The wires/strands conforming to Indian Standards can be provided with protective coatings, like galvanising or epoxy coating, carried out in specialised manufacturing units. However, if the technological processes affect any of the mechanical and physical properties, such modified properties should be taken into account in design.

18.4 Material Ingredients of Concrete

The concrete shall be prepared by using ingredients given in this Clause.

18.4.1 *Cement*

The cement shall be any of the following. The selected type should be appropriate for the intended use.

	Type	BIS Standard
(a)	Ordinary Portland Cement 33 Grade conforming to	IS 269
(b)	Ordinary Portland Cement 43 Grade conforming to	IS 269
(c)	Ordinary Portland Cement 53 Grade conforming to	IS 269
(d)	Rapid Hardening Portland Cement conforming to	IS 8041
(e)	Sulphate Resistant Portland Cement conforming to	IS 12330
(f)	Portland Pozzolana Cement conforming to	IS 1489 (Part-I)
(g)	Portland Blast Furnace Slag Cement conforming to	IS 455
(h)	Low Heat Portland Cement conforming to	IS 12600

If any other cement conforming to other International Standards is used, it shall be corresponding to one of the types listed above and shall meet the minimum specifications of the Indian Standards.

18.4.2 *Chemical admixtures*

Chemical admixtures and superplasticisers conforming to IS:9103 may be used. Compatibility of the superplasticiser with the cement and any other pozzolanic or hydraulic additives as covered in Clause 18.4.3 being used, should be ensured by trials, so that the following problems are avoided:

- Large dosage of superplasticiser required to achieve the desired workability,
- Excessive retardation of setting,
- Excessive entrainment of large air bubbles,
- Unusually rapid stiffening of concrete,
- Rapid slump loss, and
- Excessive segregation and bleeding.

18.4.3 *Mineral admixtures*

The following mineral admixtures may be used in concrete to improve its performance:

- (a) Fly ash conforming to Grade-I of IS 3812. The proportion should not be less than 20 percent nor should exceed 35 percent of the total mass of Ordinary Portland Cement and fly-ash.
- (b) Ground Granulated Blast-Furnace Slag (GGBS) conforming to IS 12089. The proportion should not be less than 50 percent nor should exceed 70 percent of total mass of Ordinary Portland Cement and GGBS.
- (c) Silica fume conforming to IS 15388. Silica fume should be very fine, non-crystalline SiO₂, obtained as a by-product of Silicon or Ferro-Silicon alloy industries.

18.4.4 *Aggregates*

18.4.4.1 General

All coarse and fine aggregates shall conform to IS:383 and shall be tested to conform to IS:2386 Parts I to VIII.

18.4.4.2 Coarse and fine aggregates

- (1) Coarse aggregates shall consist of clean, hard, strong, dense, nonporous and durable pieces of crushed stone, crushed gravel, natural gravel or a suitable combination thereof or other approved inert material.
- (2) The maximum size of the coarse aggregate may be as large as possible within the limits specified, but in no case greater than (a) one quarter of the minimum thickness of member, (b) 10 mm less than the minimum lateral clear distance between individual reinforcements or (c) 10 mm less than the minimum clear cover to any reinforcement.
- (3) The preferred nominal size of aggregate is 20 mm for reinforced concrete and prestressed concrete. However, larger sizes upto 40 mm may be permitted in special cases, when there is no restriction to flow of concrete in a section.
For plain concrete, preferred nominal sizes may be between 20 mm and 40 mm. However, larger sizes may be permitted only in special cases, subject to supplemental specifications and precautions.
- (4) Fine aggregates shall consist of hard, strong, durable clean particles of natural sand, crushed stone or gravel or suitable combination of natural sand and crushed stone or gravel.
- (5) The coarse and fine aggregates shall not contain dust, lumps, soft or flaky particles, mica and other deleterious materials in such quantities as would reduce the strength or durability of concrete or attack the reinforcement.
- (6) Grading of aggregates shall be such as to produce a dense concrete of the specified strength, which can be worked readily into position without segregation and without the use of excessive water content.

18.4.5 *Water*

Water used for mixing and curing shall be clean and free from injurious amounts of oils, acids, alkalis, salts, sugar, organic materials or other substances that may be deleterious to concrete or steel.

- (1) In case of doubt regarding development of strength, the suitability of water for producing concrete shall be ascertained by the compressive strength and initial setting time tests specified in (3) & (4).
- (2) The sample of water taken for testing shall represent the water proposed to be used for concreting, due account being paid to seasonal variation. The sample shall not receive any treatment before testing other than that envisaged in the regular supply of water proposed for use in concrete. The sample shall be stored in a clean container previously rinsed out with similar water.

- (3) Average 28 days compressive strength of at least three 150 mm concrete cubes prepared with water proposed to be used, shall not be less than 90 percent of the average strength of three similar concrete cubes prepared with distilled water. The cubes shall be prepared, cured and tested in accordance with the requirements of IS:516.
- (4) The initial setting time of test block made with the appropriate cement and the water proposed to be used, shall not be less than 30 minutes and shall not be more than 30 minutes from the initial setting time of control test block prepared with the same cement and distilled water. The test blocks shall be prepared and tested in accordance with the requirements of IS 4031 (Part 5).
- (5) The pH value of water shall not be less than 6. Potable water is generally considered satisfactory for mixing concrete. As a guide the following concentrations represent the maximum permissible values:
- To neutralise 100 ml sample of water, using phenolphthalein as an indicator, it should not require more than 5 ml of 0.02 normal NaOH. The details of test are given in Clause 8.1 of IS 3025 (Part 22).
 - To neutralise 100 ml sample of water, using mixed indicator, it should not require more than 25 ml of 0.02 normal H_2SO_4 . The details of test shall be as given in Clause 8 of IS 3025 (Part 23).
 - Permissible limits for solids shall be as given in **Table 18.6**.

Table 18.6 Permissible Limit for Solids

	Tested as per	Maximum Permissible Limit
Organic	IS 3025 (Pt. 18)	200 mg/liter
Inorganic	IS 3025 (Pt. 18)	3000 mg/liter
Sulphates (as SO_3)	IS 3025 (Pt. 28)	400 mg/liter
Chlorides (as Cl^-)	IS 3025 (Pt. 32)	- 2000 mg/liter for concrete work not containing embedded steel, and - 500 mg/liter for prestressed/reinforced concrete work
Suspended matter	IS 3025 (Pt. 17)	2000 mg/lit.

- (6) Mixing or curing of concrete with sea water is not permitted due to presence of harmful salts in sea water.
- (7) Water found satisfactory for mixing is also suitable for curing concrete. However, water used for curing should not produce any objectionable stain or unsightly deposit on the concrete surface. The presence of tannic acid or iron compounds in the water, is objectionable.

18.5 Mix Proportions of Concrete

18.5.1 Grade designation

The concrete shall be designated by one of its types as described in Clause 6.4.2 – Ordinary Concrete, Standard Concrete, or High Performance Concrete and its grade-designation based on characteristic strength as described in **Table 6.8**.

Except ordinary concrete with strength designations of M-15 & M-20, the design mix of standard concrete and high performance concrete shall be established by laboratory / field testing and controlled at site by conducting tests to confirm suitability of constituent materials, as per the relevant codes mentioned in Clause 18.4. The concrete shall meet the acceptance criteria as per Clause 18.6. Mix design shall be modified if it does not meet the acceptance criteria.

18.5.2 *Proportion of ordinary concrete*

- (1) The proportions of ordinary concrete shall be as per **Table 18.7**.
- (2) Chemical and Mineral admixtures shall not be used for Ordinary Concrete.

Table 18.7 Proportion of Ordinary Concrete

Concrete Grade	Total Quantity of dry aggregate by mass per 50 kg of cement to be taken as the sum of individual masses of fine and coarse aggregate (Kg)	Proportion of fine aggregate to coarse aggregate (by mass)	Maximum quantity of water per 50kg of cement (litres)	
			P.C.C.	R.C.C.
M15	350	Generally 1:2, subject to upper limit 1:1.5 and lower limit 1:2.5	25	-
M20	250		25	22

18.5.3 *Requirement of design mixes*

(1) **Trial Mixes**

Trial mixes shall be prepared using sample of approved materials for the initial design.

Additional trial mixes and tests shall be carried out during production in case any changes in the properties of fresh concrete and/or strength of hardened concrete on the basis of early age tests, are observed, so as to control and bring the quality of concrete within acceptable limits. In case of any change in the source of materials, or properties of materials, the design of mix shall be newly established.

(2) **Procedure for Design of Mix**

Procedures as per any national code or any procedure established by practice for arriving at the suitable mix design, can be followed. Where earlier experience of concrete made from the selected materials is available, the same can provide the basis for the start of the mix design.

The target mean strength of concrete shall exceed the specified characteristic strength by at least the margin (called current margin) taken as 1.645 times the standard deviation of sample test results taken from at least 30 separate batches of concrete of nominally similar proportions produced at site by the same plant under similar supervision, over a period exceeding 5 days, but not exceeding one month.

Where sufficient data as above to establish the standard deviation is not available, the current margin for the initial mix design shall be taken as 10 MPa, (i.e. standard deviation as 6 MPa) for normal and uniform conditions of quality controls. This initial current margin shall be used only until sufficient data are available to determine the current margin as described above.

(3) Mix Design for High Performance Concrete

General: Choice of materials, concrete mix design and field practices are quite critical, so that optimum performance can be extracted of each of the ingredients. The procedure of mix proportioning of normal grades of concrete may not be adequate. Relationships between the compressive strength of concrete and water/cement ratio (or water-cement + cementitious materials ratio, when part of the cement is replaced by mineral admixtures) and between water content and workability will have to be established by laboratory trials for the grade of concrete, the materials to be used, and the water-reducing efficiency of the superplasticiser.

The minimum cement content of concrete, inclusive of any mineral admixtures, shall be not less than 380 kg/m³.

The ratio of water/(all cementitious materials including cement) should generally not exceed 0.33, but in no case more than 0.40.

Field Trial Mixes: Mix proportions arrived at by laboratory trials shall, in addition, be verified to be satisfactory under field conditions and necessary adjustments made. Field trial mixes shall be prepared for all grades of concrete, using samples of approved materials.

The concreting plant and means of transportation employed to make trial mixes and to transport them to representative distances shall be similar to the corresponding plant and transport to be used in the works. The optimum sequence of mixing of ingredients shall be established by trials. Mixing time may be longer than in normal grade concrete mixes.

The temperature of concrete at the time of placement shall not exceed 25°C. The temperature of concrete at the mixing stage should be lower, to allow for rise in temperature during transport. When considerable distance of transport is involved, particular attention should be paid to ensure retention of slump as targeted for placement.

Use of Mock-up Testing: Further mock-up testing may be carried out to ensure that the concrete can be satisfactorily placed and compacted, taking into account the location of placement and provision of reinforcement, and adjustments made in concrete mix design and/or detailing of reinforcement accordingly.

18.5.4 *Sampling and testing*

(1) **General**

- (a) Samples from fresh concrete shall be taken as per IS 1199 and samples shall be made, cured and tested at specified number of days in accordance with IS 516. The strength parameters are based to 28 days strength. Tests at other age shall be performed, if specified.
- (b) Where automated batching plant is located away from the place of use or concrete is supplied from Ready Mixed Concrete (RMC) Plant, and the time gap between production and placement is more than the initial setting time or where any ingredients are added subsequent to mixing, separate sets of samples shall be collected and tested at batching plant and at location of placement. The results shall be compared and used to make suitable

adjustments at batching plants so that properties of concrete at placement are as per the requirements.

- (c) In order to get a relatively quicker idea of the quality of concrete, optional tests on beams for modulus of rupture at 72 ± 2 h or at 7 days, or compressive strength tests at 7 days may be carried out in addition to 28 days compressive strength test. For this purpose, the acceptable values should be arrived at, based on actual testing. In all the cases, the equivalent 28 days compressive strength shall be the criterion for the acceptance/rejection of the concrete.
- (d) Additional samples may be required for various purposes such as to determine the strength of concrete at 7 days or at the time of transfer of prestress or striking the formwork, or to determine the duration of curing, or to check the testing error. Additional samples may also be required for testing samples cured by accelerated methods as described in IS 9013. The specimen shall be tested as described in IS 516.

(2) Test Specimen and Sample Strength

Three test specimens constitute one sample for any type of test at specified age of testing. The average of these results of three samples constitute the test result of sample provided that the individual variation is within ± 15 percent of average. If variation is larger, the sample shall be discarded.

(3) Frequency of Sampling

The minimum frequency of sampling of concrete of each grade shall be in accordance with **Table 18.8**.

Table 18.8 Minimum Frequency of Sampling of Concrete

Quantity of Concrete in Work (m ³)	Number of Samples
1-5	1
6-15	2
16-30	3
31-50	4
51 and above	4 plus one additional sample for each additional 50 m ³ or part thereof.

At least one sample shall be taken from each batch of work. For the purpose of acceptance as per **Table 18.8**, quantity of concrete represented by a group of four consecutive samples shall include all batches and single sample shall represent the batch from which it is taken.

Where concrete is provided continuously at site from a batching plant or RMC plant, groups of four consecutive samples, shall not have overlapping common samples. Irrespective of other methods of controlling production used at the batching/RMC plant the requirements of this Clause shall be met.

18.6 Acceptance Criteria

18.6.1 *General*

Acceptance or rejection of concrete is mostly based on compressive strength. However, other properties of the concrete in fresh and hardened states including durability are also important.

Apart from meeting the acceptance criteria given below, concrete is liable to be rejected if it is porous or honey-combed, its placing has been interrupted without providing a proper construction joint, the reinforcement has been displaced beyond the tolerances specified, or construction tolerances have not been met. However, the hardened concrete may be accepted after carrying out suitable remedial measures.

18.6.2 *Compressive strength*

When both the following conditions are met, the concrete shall be deemed to comply with the specified compressive strength:

- (a) The mean strength determined from any group of four consecutive non-overlapping samples shall exceed the specified characteristic compressive strength by 3 MPa.
- (b) Strength of any sample is not less than the specified characteristic compressive strength minus 3 MPa.

Concrete of each grade shall be assessed separately.

If the concrete is deemed not to comply as per the above criteria, the structural adequacy of the bridge elements affected shall be investigated and any consequential action as needed, shall be taken.

18.6.3 *Flexural strength*

When both the following conditions are met, the concrete complies with the specified flexural strength:

- (a) The mean strength determined from any group of four consecutive non-overlapping samples exceeds the specified characteristic flexural strength by at least 0.3 MPa.
- (b) The strength determined from any sample is not less than the specified characteristic flexural strength minus 0.3 MPa.

18.6.4 *Density of fresh concrete*

Where minimum density of fresh concrete is specified, the mean of any four consecutive non-overlapping samples shall not be less than the specified value and any individual sample result shall not be less than 97.5 percent of the specified value.

18.6.5 *Density of hardened concrete*

Where minimum density of hardened concrete is specified, the mean of any four consecutive non-overlapping samples shall not be less than the specified value and any individual sample result shall not be less than 97.5 percent of the specified value.

18.6.6 *Chloride content*

The chloride content in the concrete can be measured as described in IS 14959 – Part I (for fresh concrete) or Part II (for hardened concrete). Alternatively it can be calculated, in which case, the method of calculation shall be based upon the measured chloride-ion contents of all constituents and the mix proportion of concrete. The chloride-ion content so measured or calculated and expressed as the percentage of chloride-ion by mass of cement, shall not exceed the value specified in Clause 14.3.2.3.

18.6.7 *Durability of concrete*

Unlike the tests on concrete described above, there is no specified test method for durability, which can be completed within a reasonably short time. The requirement of long term durability of concrete is ‘deemed to be satisfied’ by following the recommended provisions in this Code for maximum water-cement ratio, minimum cement content, cover thickness, type of cement and amounts of chlorides and sulphates in concrete etc. All these recommendations taken together tend resulting concrete being dense, workable, and placeable and having as low permeability as possible under the given situation.

When durability of concrete is the main reason for adopting high performance concrete, or in other specific situations, Rapid Chloride Ion Permeability Test (RCPT) as per ASTM C1202 shall be carried out. Suggested upper limits of values of RCPT for 56 days for various exposure conditions (refer **Table 14.1**) are:

- | | | |
|-----|-------------|---------------|
| (1) | Extreme | 800 Coulombs |
| (2) | Very Severe | 1200 Coulombs |
| (3) | Severe | 1500 Coulombs |

Additional durability tests, such as Water Permeability test as per DIN 1048 Part 5 or Initial Surface Absorption test as per BS 1881 Part 5 can also be specified. The permissible values in such tests have to be specified taking into account the severity of the exposure condition. The acceptance criteria shall be arrived at prior to testing.

18.7 **Self-Compacting Concrete****18.7.1** *Constituents*

In Self-Compacting Concrete, superplasticisers provide the fluidity, and Viscosity Modifying Admixtures (VMA) are used to help reduce segregation, and sensitivity of the mix due to variations in other constituents, especially to moisture content. Other materials are as in Clauses 18.4.1 to 18.4.5.

VMA's are hydrophilic, water-soluble polymers having high molecular weight. Such polymers can form a network of large molecules extending throughout the mass. The dimensions of the polymers or particles are in colloidal range; hence these are called ‘colloidal admixtures’. These can also be used as ‘anti-washout’ admixtures for underwater placement.

18.7.2 Properties in the Fresh State

The filling ability and stability of self-compacting concrete in the fresh state can be defined by four key characteristics. Each characteristic can be assessed by one or more test methods (Table 18.9).

Table 18.9. Characteristics of SCC and Tests

Characteristics	Preferred Test Method(s)	Limit of Test Value
Flowability	Slump-flow test	550 – 850 mm
Flowability	T ₅₀₀ Slump flow test	2 sec
	V-funnel test	8 – 25 sec
Passing ability	L-box test	0.8
Segregation	Segregation resistance (sieve) test	15 – 20 per cent

Note: For details of the test methods and limiting test values, as appropriate to placing conditions, amount and congestion of reinforcement, dimensions of the members, size of aggregate etc., EFNARC Guidelines for Self-Compacting Concrete, May 2005 may be referred.

Fig. 18.1 gives the dimensions of the test equipment.

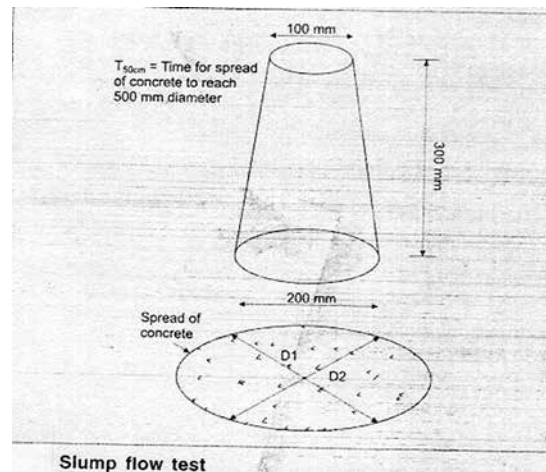

Fig. 18.1 (a) Slump Flow Test

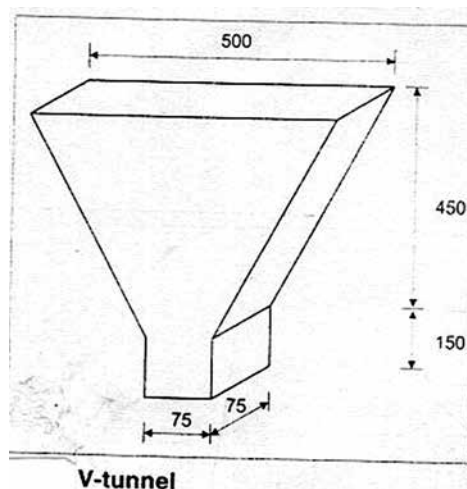

Fig. 18.1 (b) V – Funnel Test

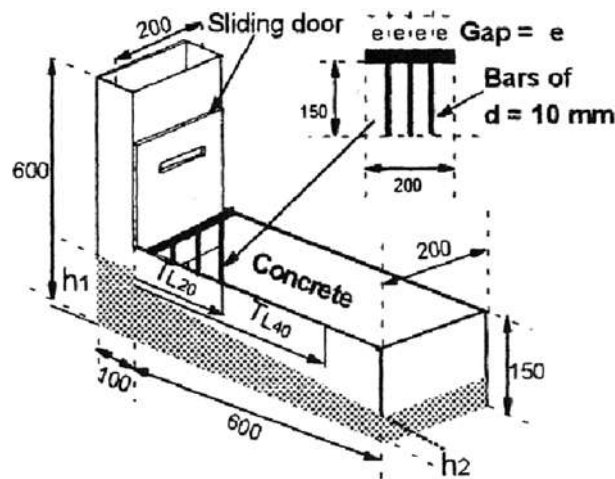

Fig. 18.1 (c) L Box Test
Fig. 18.1 Test Equipment for SCC

18.7.3 Mix Design

There is no fixed method of mix design for SCC. Mix proportions are to be selected by trials and tests, till a satisfactory mix is arrived at. EFNARC Guidelines 2005 suggest broad outline, as given below:

- Coarse aggregate content - 750 – 1000 kg per m³ of concrete,
- Total powder content – 380 to 600 kg per m³ of concrete,
- Water/powder ratio by solid volume – 0.85 to 1.10,
- Water content – 150 – 210 litres/ m³,
- Paste volume – 300 – 380 litres/ m³,
- Water/cement ratio selected for strength and durability requirements,
- Sand content to balance the remaining volume, usually 48 – 55 % of total aggregate by weight.

18.8 Grouting

18.8.1 General

Grout is a homogenous mixture of cement and water. It may contain chemical admixtures which modify the properties of grout in its fluid state. These recommendations cover the cement grouting of post tensioned tendons of prestressed concrete members of bridges.

The purpose of grouting is to provide permanent protection to the post tensioned steel against corrosion and to develop bond between the prestressing steel and the surrounding structural concrete. The grout ensures encasement of steel in an alkaline environment for corrosion protection and by filling the duct space it prevents water collection and freezing.

A critical feature of grout is that it should remain pumpable for the time required to fully inject the tendon.

18.8.2 *Materials*

(1) **Water**

Only clean potable water free from impurities conforming to Clause 18.4.5 shall be used. No sea or creek water is to be used at all.

(2) **Cement**

The same type of cement as used in construction of prestressed elements, should be used for preparation of the grout. It should be as fresh as possible and free from any lumps.

(3) **Sand**

It is not recommended to use sand for grouting of prestressing tendons.

(4) **Admixtures**

Acceptable admixtures conforming to IS 9103 may be used if tests have shown that their use improves the properties of grout, i.e. increasing fluidity, reducing bleeding, entraining air or expanding the grout. Admixtures must not contain chlorides, nitrates, sulphides, sulphites or any other products which are likely to damage the steel or grout. When an expanding agent is used, the total unrestrained expansion should not exceed 10 percent. Aluminium powder as an expanding agent is not recommended as doubts exist about its long term effects.

(5) **Ready Mixed grout**

Alternatively, the dry materials may be batched in a factory for pre-mixed grout and mixed with the liquid materials on site as per instructions of the manufacturers.

18.8.3 *Use of grout colloidal mixer*

It is essential that the grout is maintained in a homogenous state and of uniform consistency so that there is no separation of cement during the entire grouting process. It is, therefore, necessary that the grout be continuously mixed in a colloidal mixer with a minimum speed of 1000 RPM and travel of discharge not exceeding 15 m per second.

18.8.4 *Properties of the grout*

Before grouting, the properties of the grout mix should be tested. Tests should be conducted for each job periodically.

(1) **Water/cement Ratio**

Water/cement ratio should be as low as possible, consistent with workability and should not exceed 0.40.

(2) Deleterious Materials

No chloride, sulphates shall be separately added to the grout. The constituent may contain chlorides/ sulphates. However, its net effect should not exceed the following limits in the grout:

- Chlorides (Cl⁻) not more than 0.1 percent by weight of cement.
- Sulphate (SO₃²⁻) not more than 4 percent by weight of cement.
- Sulphide-ions (S₂⁻) not more than 0.01 percent by weight of cement.

(3) Temperature

The temperature of the grout after accounting for the ambient temperature of the structure, shall not exceed 25°C.

(4) Compressive Strength

The compressive strength of 100 mm cube of the grout shall not be less than 27 MPa at 7 days or 30 MPa at 28 days. Cubes shall be cured in a moist atmosphere for the first 24 hours and subsequently in water. These tests shall be conducted in advance to ascertain the suitability of the grout mix. The 7 day strength is not mandatory if the 28 day strength requirement is met.

(5) Setting Time

Initial setting time of grout shall be more than three hours and less than 12 hours. The final setting time shall not be less than 24 hours.

(6) Bleeding

Bleeding is the separation of free water from the grout mix. It includes the filtering effect of strands where the cavities between the wires constituting the strand, block cement particles and permit water under pressure to move ahead of the grout in the direction of general flow of grout. The bleeding shall be sufficiently low to prevent excessive segregation and sediment of the grout material. The bleeding shall not exceed 0.3 percent of volume of the initial volume of grout after three hours kept at rest.

(7) Volume Change

Volume change of the grout at rest for 24 h shall be within the range of - 1 % and + 5 % of the original volume when tested as per EN 445. It should not be more than +0.2 percent at 28 days.

(8) Fluidity

Fluidity is tested as per EN 445 by a) cone test and b) grout spread test. The time for cone test (as per **Fig 18.2a**) shall be less than or equal to 25 seconds. The spread of the grout as per grout spread test (as per **Fig 18.2b**) shall be greater than or equal to 140 mm.

For retention of fluidity there shall not be more than 20% reduction in fluidity at 30 minutes when tested as per EN 445.

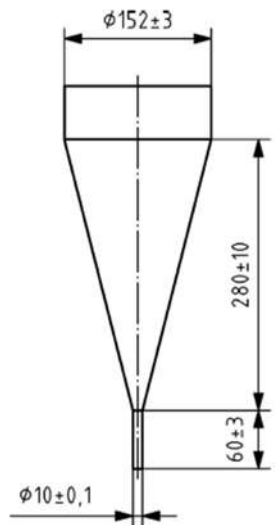
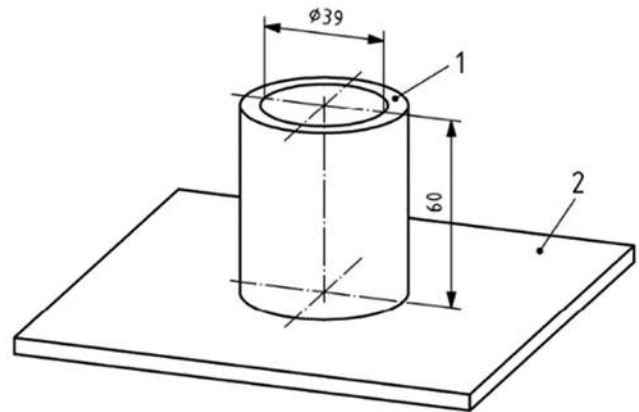

Fig 18.2 (a) – Cone for fluidity test (as per EN 445)



1- Cylinder (steel or plastic tube)
2- Smooth plate

Fig 18.2 (b) – Grout spread test (as per EN 445)

(9) Tests for Bleed and Volume Change

Wick Induced Bleed and volume change test shall be as per EN 445. The details of the test are given in Fig. 18.2 (c).

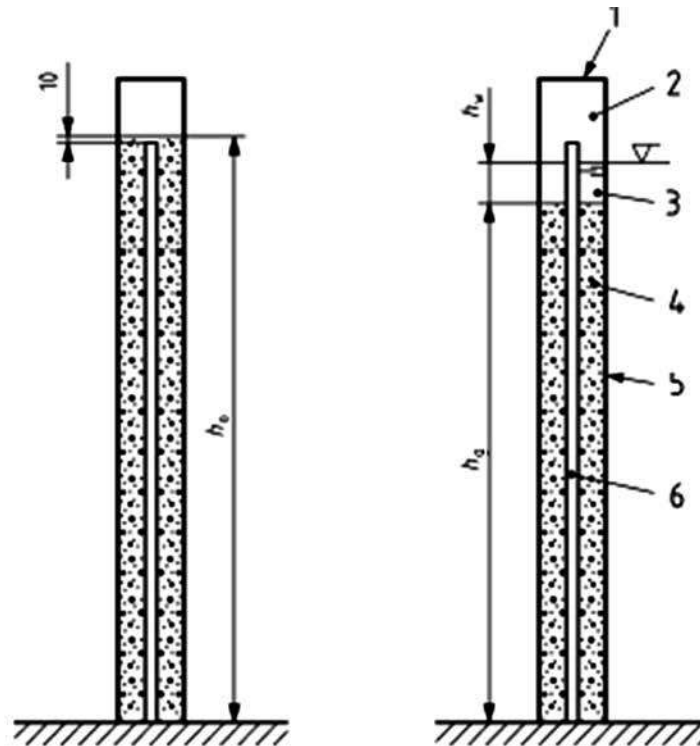

- 1- Seal
- 2- Air
- 3 - Water

- 4- Grout
- 5- Transparent tube
- 6- Strand, wires or bar

h_o - height at t_o
 h_n - height at t_n

Fig 18.2 (c) – Wick induced test setup (as per EN 445)

Alternatively, the inclined tube bleed test can be done to determine the bleed properties and volume stability of grout. The details of the test are shown in **Fig. 18.2(d)**.

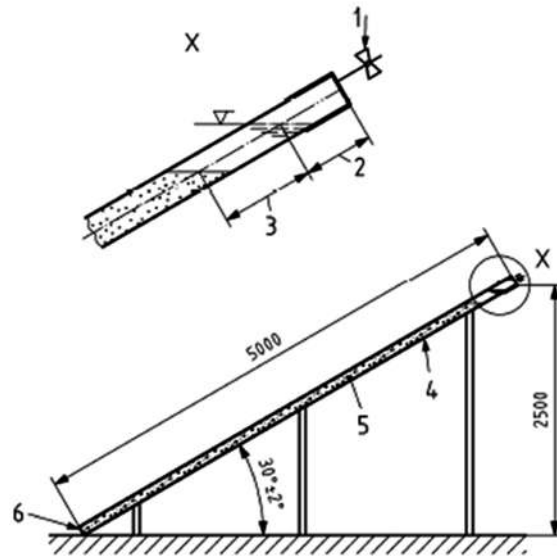

- | | |
|------------------------|-----------------------|
| 1- Vent and stop valve | 4- Transparent tube |
| 2- Air | 5- 12 strands |
| 3 - Water | 6- Injection of grout |

Fig 18.2 (d) – Inclined tube test set up (as per EN 445)

18.8.5 Grouting Procedure

The grouting procedure shall be as per EN 446. Guidelines for grouting are given below:

- Ducts should be grouted at a continuous and steady rate of 6 to 12 m / minute for horizontal and 2 to 3 m / minute for vertical ducts. For parabolic ducts the grouting rate should be 6 to 8 m / minute.
- Grouting pressure should not exceed 2 MPa.
- Grouting should continue until the fluidity or density of grout flowing from free ends and vent openings is same as that of original grout.

After closing all the vents, retained pressure should be same as adopted for grouting subject to a minimum of 0.5 MPa.

18.9 Quality Control and Workmanship

18.9.1 General

This Clause covers the requirements of proper workmanship in all operations of construction of concrete structures and related quality assurance and quality control measures, so that the structure is built as designed and the intended performance over the design service life is achieved. Concrete is made with ingredients with inherent variability. The operations of production, placement, compaction and curing of concrete under site conditions can also exhibit variability. In order that concrete is

obtained with reasonable amount of consistency in its characteristics, the properties of ingredients and the resultant concrete should be monitored diligently as per an appropriate plan of testing and all site operations should be carried out with adequate proficiency, as detailed in this Section. A Quality Assurance (QA) Plan should be in position to ensure that the construction results in satisfactory strength, serviceability and long term durability which will lower the overall lifecycle cost of the structure.

18.9.2 Quality assurance measures

Quality assurance in construction activity relates to proper design, use of appropriate materials and components to be supplied by the producers, proper workmanship in the execution of works and proper care during the use of structure, including periodic inspection and timely maintenance and repair by the owner.

Quality assurance measures are both technical and organizational. The Quality Assurance Plan shall identify the key elements necessary to provide fitness of the structure and the means by which they are to be provided and measured with the overall purpose to provide confidence that the realized project will work satisfactorily in service, fulfilling intended needs. Quality control and quality assurance would also involve ensuring quality of both the inputs as well as the outputs. Inputs are in the form of materials of construction; workmanship; and the related plant, machinery and equipment; resulting in the output in the form of final structure.

Each party involved in the realization of a project should establish and implement a Quality Assurance Plan for its role in the project. Suppliers' and sub-contractors' activities shall be covered in the plan. The individual Quality Assurance Plans shall fit into the overall Quality Assurance Plan of the project and shall define the tasks and responsibilities of all persons involved, adequate control and checking procedures, and the organization and maintaining of adequate documentation of the construction process and its results. Such documentation shall be in accordance with IRC Publication IRC:SP:47-1988 "Guidelines on Quality Systems for Road Bridges, Plain, Reinforced Prestressed and Composite Concrete".

18.9.3 Production of concrete

(1) Storage of Materials

All efforts shall be made to store the materials in proper places to prevent their deterioration and any intrusion of foreign matters, so as to ensure their satisfactory quality and fitness for the work. The space shall permit easy storage, inspection, removal and re-storage of materials. All such materials, even though stored in approved manner, shall be subjected to inspection and acceptance test prior to use, whenever considered necessary.

(2) Batching

In batching concrete:

- The quantity of cement, aggregate and mineral admixtures, if used, shall be determined by mass.

- Chemical admixture, if solid, shall be determined by mass.
- Liquid admixture may be measured in volume or mass, and
- Water shall be weighed or measured by volume in a calibrated tank.

The concrete shall be sourced from on-site or off-site batching and mixing plants, or from approved ready-mixed concrete plants, preferably having quality certification.

Except where supply of properly graded aggregate of uniform quality can be maintained over a period of work, the grading of aggregate should be controlled by obtaining the coarse aggregate in different sizes and blending them in the right proportions when required, the different sizes being stocked in separate stock piles. The material should be stock piled several hours, preferably a day before use. The grading of coarse and fine aggregate should be checked as frequently as possible to ensure that the specified grading is maintained.

The accuracy of the measuring equipment shall be within ± 3 percent of the quantity of cement, aggregate, admixtures and water being measured. All measuring equipment shall be maintained in a clean and serviceable condition. Their accuracy shall be checked over the range in use, when set up at site and maintained thereafter.

It is important to maintain the water-cement ratio constant at its correct value. To this end, determination of moisture contents in both fine and coarse aggregates shall be made as frequently as possible, being determined according to weather conditions. The amount of the added water shall be adjusted to compensate for any observed variations in the moisture contents. To allow for the variation in mass of aggregate due to variation in their moisture content, suitable adjustments in the masses of aggregates shall also be made. Accurate control shall be kept on the quantity of mixing water, which when specified, shall not be changed without approval.

(3) Mixing

All concrete shall be machine-mixed. In order to ensure uniformity and good quality of concrete, the ingredients shall be mixed in a power driven batch mixer with hopper and suitable weigh batching arrangement or in a central mix plant. The concrete shall be mixed until it is of even colour, cohesive and of uniform consistency throughout. When mineral admixtures are added at the mixing stage, their thorough and uniform blending with the cement shall be ensured, if necessary, by longer mixing time. In general, the mixing time shall be at least 2 minutes after all the ingredients are in the mixer. For other types of more efficient mixers, manufacturer's recommendations should be followed. The addition of water after the completion of the initial mixing operation, shall not be permitted.

18.9.4 *Transportation, placing, compaction and curing*

(1) Transporting Concrete

Mixed concrete shall be transported from the place of mixing to the place of final placement as early as practicable, by methods which will prevent the segregation or loss of the ingredients.

Concrete may be transported by transit mixers or properly designed buckets or by pumping. Transit mixer or other hauling equipment when used, should be equipped with means of discharging the concrete

without segregation. During hot or cold weather, concrete shall be transported in deep containers. Other suitable methods to reduce the loss of water by evaporation in hot weather, and heat loss in cold weather, may also be adopted.

When concrete is conveyed by chute, the plant shall be of such size and design as to ensure practically continuous flow in the chute. The slope of the chute shall be such as to allow the concrete to flow freely and without segregation of the ingredients. The delivery end of the chute shall be as close as possible to the point of deposit. The chute shall be thoroughly flushed with water before and after each working period and the water used for this purpose shall be discharged outside the formwork.

In case concrete is to be transported by pumping, the fresh concrete should have adequate fluidity and cohesiveness to be pumpable. Proper concrete mix proportioning and initial trials should be carried out to ensure this. The conduit shall be primed by pumping a batch of mortar through the line to lubricate it. Once the pumping is started, it shall not be interrupted, as concrete standing idle in the line is liable to cause a plug. The operator shall ensure that some concrete is always there in the pump's receiving hopper during operation. The lines shall always be maintained clean and free of dents.

(2) Placing and Compacting Concrete

Concrete shall be placed as nearly as practicable in its final position to avoid rehandling. Methods of placing should be such as to preclude segregation. Care should be taken to avoid displacement of reinforcement or movement of formwork. To achieve this, concrete should be lowered vertically into the forms and horizontal movement of concrete inside the forms should, as far as practicable, be minimised.

Concrete shall be placed and compacted before its initial setting so that it is amenable to compaction by vibration. The workability of concrete at the time of placement shall be adequate for the compaction equipment to be used. If there is considerable time gap between mixing and placing of concrete, as in the case of ready mixed concrete plants or off-site batching and mixing plants, concrete mix shall be designed to have appropriately higher workability at the time of discharge from the mixer, in order to compensate the loss of workability during transit. This is generally achieved by use of suitable chemical admixtures. Keeping these considerations in view, the general requirement for ready mixed concrete plants or off-site batching and mixing plants, is that concrete shall be discharged from the truck mixer within two hours of the time of loading. A longer period may be permitted if suitable retarding admixtures are used. In case of on-site mixing, fresh concrete shall preferably be placed and compacted within 30 minutes of mixing.

In wall forms, drop chutes attached to hoppers at the top should preferably be used to lower concrete to the bottom of the form. As a general guidance, the permissible free fall of concrete may not exceed 1.5 m and under no circumstances; shall it be more than 2 m.

When free fall of larger height is involved, self compacting concrete having adequate fluidity, cohesiveness and viscosity shall be used. Self compacting concrete completely fills every corner of the formwork by its own weight without segregation, whilst maintaining uniformity. No compaction by vibration is required.

When concrete is to be deposited by means of tremie, the lower end of the vertical pipe shall always be inserted sufficiently deep into the concrete which has been placed previously but has not set. The top section of the tremie shall be a hopper large enough to hold one entire batch of the mix or the entire contents of the transporting bucket, if any. The tremie pipe shall be large enough to allow a free flow of concrete and strong enough to withstand the external pressure of the water in which it is suspended, when concrete is deposited under water. It will be necessary to raise the tremie slowly in order to cause a uniform flow of the concrete, but the tremie shall not be emptied allowing water to enter the pipe. At all times after the placing of concrete is started and until all the concrete is placed, the lower end of the tremie pipe shall be below the top surface of the plastic concrete.

Concrete shall be thoroughly compacted during the operation of placing and carefully worked around the reinforcement, around embedded fixtures and into the corners of the form work. To achieve proper compaction vibrators may be used. The vibrator can be internal or external type and depending upon the shape and size of the member, both types may be used individually or together.

When internal vibrators are used, they shall be inserted vertically to the full depth of the layer being placed and ordinarily shall penetrate the layer below for a few centimetres. The vibrator should be kept in place until air bubbles cease escaping from the surface and then withdrawn slowly to ensure that no hole is left in the concrete, care being taken to see that it remains in continuous operation while being withdrawn. Internal vibrators shall be inserted in an orderly manner and the distance between insertions should be about 1½ times the radius of the area visibly affected by vibration. Internal vibrators should not be used for spreading the concrete.

(3) Construction Joints

Concreting shall be carried out continuously up to construction joints, the position and arrangement of which shall be pre-determined by the designer. Joints should be positioned where they are readily accessible for preparation and concreting. Construction joints should be positioned to minimise the effects of the discontinuity on the durability, structural integrity and appearance of the structure. As far as possible, joints should be provided in non-aggressive zones, but if joints in aggressive zones can not be avoided, they should be sealed. Joints should be located away from regions of maximum stress caused by loading; particularly where shear and bond stresses are high. Joints should be either vertical or horizontal. For a vertical construction joint, the lifts of concrete shall finish level or at right angles to the axis of the member. Concreting shall be continued right up to the joint.

Before resuming work at a construction joint when concrete has not yet fully hardened, all laitance shall be removed thoroughly. The surface should be roughened, care being taken to avoid dislodgement of coarse aggregates. Concrete may be brushed with a stiff brush soon after casting, while the concrete has only slightly stiffened. If the concrete has partially hardened, it may be treated by wire brushing or with a high pressure water jet, followed by drying with an air jet, just before the new concrete is placed. Fully hardened concrete shall be treated with mechanical hand tools or grit blasting, taking care not to split or crack the aggregates. The practice of first placing a layer of mortar or grout when concreting joints is not recommended. The old surface should be soaked with water, without leaving puddles, just before starting concreting. The new concrete shall be thoroughly compacted against it.

Where there is likely to be a delay before placing the next concrete lift, protruding reinforcement shall be protected. In all cases, where construction joints are made, the joint surface shall not be contaminated with release agents, dust, or sprayed curing membrane and reinforcement shall be firmly fixed in position at the correct cover.

The sequence of concreting, striking of forms and positioning of construction joints for every individual structure shall be decided, well in advance of the commencement of work.

(4) Curing and Protection of Concrete

The concrete shall be kept constantly wet for a minimum period of 14 (fourteen) days by ponding or covering with a layer of wet (but not dripping) sacking, canvas, hessian or similar absorbent material. Water should be applied on unformed surfaces as soon as it can be done without marring the surface and on formed surfaces immediately after the forms are stripped.

High Performance Concrete containing silica fume is more cohesive than normal mixes hence, there is little or no bleeding and no bleed water to rise to the surface to offset water lost due to evaporation. Plastic shrinkage cracking is possible, if curing is not proper. Initial curing should commence soon after initial setting of concrete. Concrete should be covered with moist covers (sacking, canvas or hessian), opaque colour plastic sheets or suitable curing compound. Final moist curing should commence after final setting of concrete and continue for at least 14 days.

Liquid membrane-forming curing compounds conforming to ASTM C 309, may be used in lieu of moist curing after approval. The curing efficiency shall be tested as per ASTM C 156. Such compounds shall be applied to all exposed surfaces of the concrete as soon as possible after the concrete has set, but not dried out. The membrane formed shall be stripped off afterwards. Impermeable membranes, such as sheet materials for curing concrete conforming to ASTM C 171, or polyethylene sheeting covering closely the concrete surface, may also be used to provide effective barrier against evaporation.

Steam curing under atmospheric pressure is adopted to develop high early strength of concrete, so that concrete members can be removed from the formwork and handled as early as possible. This is particularly suitable for precast concrete members. Steam curing is applied in enclosures or tunnels through which concrete members are transported on a conveyor system; alternatively, portable enclosures or plastic covers are placed over precast members. Steam is supplied to the enclosures. Various elements of the steam curing cycle, e.g. the delay in commencement of heating (i.e. extending pre-steaming period), the rate of increase of temperature, the level and time of constant temperature, and the rate of decrease of temperature, shall receive careful consideration. As a general guidance, the pre-steaming period should be about one to three hours, the rate of increase or decrease of temperature should not exceed 10°C to 20°C per hour and the maximum temperature of curing can be about 70°C. The ideal steam curing cycle in a particular situation, is governed by the concrete mix proportions and type of cementitious materials and the strength required at the end of steam curing period, and shall be decided by prior trials. Steam curing of concrete shall be followed by water curing for at least seven days.

After placing and during the first stages of hardening, concrete shall be protected from harmful effects of sunrays, drying winds, cold, running water, shocks, vibrations, traffic including construction traffic etc.

18.9.5 *Concreting in extreme weather***(1) Concreting in Hot Weather**

Special problems are encountered in the production, placement and curing of concrete in hot weather. The climatic factors affecting concrete in hot weather are high ambient temperature, reduced relative humidity, high wind velocity and combination thereof. High temperatures result in rapid hydration of cement, increased evaporation of mixing water, greater mixing water demand, rapid loss of workability and large volume changes resulting in cracks.

The temperature of the concrete at the time of placement should be as low as possible, but in no case more than 35°C. For high performance concrete, the temperature at the time of placement shall not exceed 25°C. If concreting has to be done in hot weather at ambient temperatures exceeding these limits of concrete temperature, steps shall be taken to sufficiently lower the temperature of ingredients of the concrete below the ambient. The contribution of each ingredient to the temperature of concrete is a function of the temperature, specific heat and quantity of that ingredient.

Aggregates and mixing water exert the most pronounced effects on the temperature of concrete. Thus, in hot weather, all available means shall be used for maintaining these materials at as low temperature as practicable, such as;

- Use of chilled mixing water
- Use of crushed ice or flaked as a part of mixing water.
- Shading stockpiles of aggregates from direct rays of Sun.
- Sprinkling stockpiles of coarse aggregate with water and keeping them moist.
- Limiting temperature of cement to be preferably not in excess of 30°C at the time of use.

Period between mixing of concrete and placing shall be as short as possible. Immediately after compaction and surface finish, concrete shall be protected from evaporation of moisture, without letting ingress of external water, by means of wet (not dripping) gunny bags, hessian etc. Once the concrete has attained some degree of hardening (approximately 12 hours after mixing), moist curing shall be commenced and satisfactorily continued throughout the requisite period.

(2) Concreting in Cold Weather

Effects of cold weather on concrete, in absence of special precautions, include;

- Delayed setting and hardening, slower rate of gain of strength,
- Irreparable loss of strength and durability, if freezing of concrete takes place at early ages, when it is still in plastic state. Even one cycle of freezing of concrete during the prehardening period may lower the compressive strength by 30 to 50 percent,
- Disruptive effects of freezing of pore water make hardened concrete vulnerable to repeated cycles of freezing and thawing, resulting in loss of compressive strength and modulus of elasticity.
- Stresses due to temperature differential within the concrete member at the time of removal of form insulations, may promote cracking.

When depositing concrete at or near freezing temperature, precautions shall be taken to ensure that the concrete shall have a temperature of at least 5°C at the time of placing. When necessary, concrete ingredients shall be heated before mixing, but cement shall not be heated artificially other than by the heat transmitted to it from other ingredients of the concrete. In general, heating of only the mixing water to about 65°C may suffice for this purpose.

The temperature of the concrete shall be maintained above freezing temperature (preferably above 2°C) until it has thoroughly hardened. This may be achieved with the help of proper insulating methods before the protection is removed.

Use of air-entraining admixtures conforming to IS 9103 increases the resistance of hardened concrete to freezing and thawing. To counter slower setting of concrete, non chloride-bearing accelerators can be used after approval. However, accelerators containing chloride shall not be used.

No frozen material or materials containing ice shall be used. All concrete damaged by frost shall be removed.

18.9.6 *Steel reinforcement*

(1) Bending

Reinforcement shall not be bent or straightened in a manner that will injure the material. All reinforcement shall be bent cold. Mechanised bending or prefabricated reinforcement shall be preferred. Bar bending schedules shall be prepared for all reinforcement work.

(2) Placing

All reinforcement shall be placed and maintained in positions shown on the drawings by providing proper cover blocks, spacers, supporting bars etc. High strength mortar or concrete of the same grade with smaller size aggregate shall be used for cover blocks. To ensure adequate cover, use of manufactured chairs is recommended.

(3) Splicing and Lapping

Splicing and lapping shall be in positions conforming to the drawings and for this purpose, all reinforcing bars shall be to the full lengths indicated thereon. However, suitable adjustment in the locations of the splices to accommodate the available lengths of bars, can be made with prior approval. In all cases of such adjustment, the requirements of lap length and other stipulations, as per Sections 15 and 16 shall be complied with.

(4) Substitution of Bar Sizes

In order to accommodate the available size of bars, use of bar sizes other than those shown on the drawings may be permitted with prior approval. In case of such substitution, the reinforcement actually used shall have an area equivalent to the original or slightly in excess thereof, provided further that the various stipulations of this Code are not violated by such substitution. The requirements with regard to bond stress, limitations of bar sizes, spacing of bars, cover, etc., shall be specially looked into.

18.9.7 *Falsework*

For design, fabrication, and erection of falsework, IRC:87 “Guidelines for the Design and Erection of Falsework for Road Bridges” shall be followed.

The formwork should be robust and strong and the joints should be leak proof. Form release agents of approved quality shall be used. The staging, scaffolding and shuttering are required to be properly designed so that their erection as well as striking can be conveniently done. The design should also ensure that at the time of striking, the concrete does not get disturbed and the forms are conveniently removed. Staging shall be of steel pipes or steel sections.

Where centering trusses or launching trusses are adopted for casting of superstructure, the joints of the centering or launching arrangement, whether welded, riveted or bolted, shall be thoroughly checked and various members of the centering trusses shall be examined for proper alignment and unintended deformation before proceeding with the concreting. Launching trusses and travelling forms shall be load tested.

The locations where fixing of reinforcement and placing of concrete are being done, shall be accessible to the inspecting officers at all stages of construction.

Forms shall not be released until the concrete has achieved strength of at least twice the stress to which the concrete may be subjected at the time of removal of formwork. In absence of tests, generally, the striking period may be as specified in IRC:87.

18.9.8 *Inspection and testing of structures*

(1) Inspection

To ensure proper performance, it is necessary that each step in concreting which will be covered by the next step is inspected as the work proceeds. Immediately after stripping the formwork, all concrete shall be carefully inspected and any defective work or small defects shall be either removed or made good before concrete has thoroughly hardened. Concrete members shall be inspected within 15 days for occurrence of cracks due to shrinkage, temperature, local restraint, undue deflection and deformation.

(2) Testing of Concrete in Structures

In case of doubt regarding the grade of concrete in the structure, either due to poor workmanship or based on results of cube strength tests, compressive strength tests of concrete shall be carried out by core tests and/or non-destructive tests.

(3) Core Test

The points from which core samples are to be taken and the number of core samples required shall be decided so as to be representative of the whole of concrete concerned. In no case, however, shall fewer than three cores be tested. Cores shall be prepared and tested as described in IS 516.

Concrete in the member represented by a core test shall be considered acceptable, if the average equivalent cube strength of the cores is equal to at least 85 percent of the characteristic strength of the grade of concrete specified for the corresponding age and no individual core has strength less than 75 percent.

Core tests may also be required for other purposes like repair, retrofitting and strengthening of structure where requirement of strength could differ.

(4) Non-Destructive Tests

Non-destructive tests are used to obtain estimation of the properties of concrete in the structure.

The methods adopted include ultrasonic pulse velocity [IS:13311(Part 1)] and rebound hammer [IS 13311 (Part 2)], probe penetration (ASTM C 803), pullout (ASTM C 900) and maturity (ASTM C 1074). Non-destructive tests provide alternatives to core tests for estimating the strength of concrete in a structure, or can supplement the data obtained from a limited number of core specimens tested. These methods are based on measuring a concrete property that bears some relationship to strength. The accuracy of these methods is determined by the degree of correlation between strength and quality of the concrete and the parameter measured by the non-destructive tests.

Any of these methods may be adopted, in which case the acceptance criteria shall be agreed upon prior to testing.

18.9.9 *Load tests of structures*

(1) Load Test for Flexural Member

In case the core test results do not satisfy the requirement in Clause 18.9.8 (3) or where such tests have not been done, load test may be carried out if specifically desired. Load test should be carried out as soon as possible after expiry of 28 days from time of placing of concrete. Procedure as per IRC publication SP:51 'Guidelines for Load Testing of Bridges' may be adopted.

(2) Members Other than Flexural Members

Members other than flexural members should be preferably investigated by analysis.

18.10 Design considerations for construction stages, refer to **Annexure A-6**.

ACTIONS, DESIGN SITUATIONS AND COMBINATION OF ACTIONS

A1-1 General

Section 5.0 “Basis of Design” describes the approach adopted for taking into consideration various limit states, which shall not be exceeded by the bridge structure and its elements, when subjected to combined effect of actions in various design situations. The values of actions and partial factors to be used in different combinations for verification of design by Limit State Method are given in IRC:6, **Annexure B**.

The description of actions, their classification, nomenclature of design situations and combination for verifying different limit states as applicable to concrete bridges, are explained in this Annexure. The terms loads and force (arising out of friction, buoyancy etc) are also used to represent ‘Actions’ in IRC:6, and in the description below.

A1-2 Classification of Action

The description of actions and their notations given as per IRC:6, unless otherwise stated.

(1) Permanent Actions - G

(a) Permanent Action

(i) Self Weight/Dead Load

Self-weight of structure due to gravity.

(ii) Backfill Weight

To be treated as D.L. when present.

(iii) Earth Pressure: (F_{ep})

In IRC:6, the increased earth pressure due to live load surcharge considered is included by convention in F_{ep} . For Limit State Method the surcharge due to live load needs to be taken as a variable load together with other live loads.

(iv) Prestressing Force: (P)

In analysis of structure P is considered as a force acting on concrete elements which has time dependant variation, and also superior (i.e. higher estimate) and inferior (i.e. lower estimate) values.

(v) Secondary Effects (F_s)

Such as creep, shrinkage and settlement.

Note: Second order effects arising from the deformed geometry are not considered as secondary effects. These are considered for verification of Ultimate Limit State of Deformation only.

(b) Variable Gravity Loads Treated as Permanent Loads

(i) Super Imposed Dead Load

Loads from hand rail, crash barrier, road furniture, footpath and actual or provisional loads from services, etc.

(ii) Surfacing and Wearing Coat

In Limit State Method superior and inferior values may be used, which should account for re-surfacing, with or without removing existing coat, and possibility of change in type of surfacing.

(iii) Snow Load

Snow loads, if present, are treated in the same way as Dead Load depending on the depth of snow on superstructure. The design value of live load is modified depending on the restrictions on operation of vehicular loads which give rise to different design situations.

(c) Quasi-Permanent Loads

There are variable loads which act for a major part of the structure's design life. By convention, loads acting for more than 50% of the design life are called quasi-permanent. In load combinations, they are treated as variable loads with different values depending on the action effects under evaluation. Temperature load is an example, where it has a permanent component (casting temperature), semi-permanent component (seasonal variation from casting temperature) and varying component (daily variation from seasonal temperature).

(2) Variable Actions – Q **(a) Vehicular****(i) Vehicular live load (Q)**

Load due to gravity

(ii) Impact factor due to vehicular gravity load (Q_{im})

A factor for converting dynamic increment of gravity load, due to vehicle travelling at high speed on uneven surface of wearing coat, to equivalent static load.

(iii) Longitudinal forces

- Caused by tractive effort of vehicles (F_a) or by braking (F_b) and / or
- Longitudinal force from bearings due to their type and configuration (F_p).

(iv) Centrifugal force of vehicles travelling at high speed along a curved track F_{cf} **(v) Pedestrian Load/Foot Path Load****(vi) Earth Pressure Surcharge Effect due to Live Load (F_{cp})****(b) Loads of Environmental Origin****(i) Temperature effects due to restraints to free structural deformation (F_{de}) (excluding restraints due to frictional resistance at bearings).****(ii) Effect of thermal gradient in the structure.****(iii) Wind Load (W)**

Normally used as static load acting on bridge elements. For wind sensitive structure or elements of structure, dynamic analysis and dynamic wind force is stipulated.

(c) Hydraulic Actions

These are variable loads, grouped together as sub-set of variable loads and their significant effect in bridge design.

- (i) **Buoyancy effect** (G_b)
- (ii) **Water current forces** (F_{wc})
Including both drag and lift effects.
- (iii) **Wave Pressures** (F_{wp})

(3) Accidental Actions

Accidental loads are those loads whose occurrence or frequency cannot be predicted, and originate from unintended or undesirable situations.

(a) Impact of external bodies

- (i) Vehicle collision on elements of bridge structure (V_c).
- (ii) Barge impact or impact due to floating bodies in water current.
- (iii) Vehicular Impact on Crash Barriers.

(b) Seismic Hazards

Seismic situations considered in the design are rare events [even more rare than type 3(a)] having return period of the order of few hundred years. They produce following types of loads.

- (i) Inertial loads due to self-mass, generated in bridge structure by ground acceleration.
- (ii) Inertial loads due to mass of vehicular live load.
- (iii) Hydrodynamic forces generated on parts of bridge submerged under water.
- (iv) Increased earth pressures.
- (v) Effects of liquefaction of soils.

A1-3 Design Situation and Load Combination

Various actions defined in Clause A1-2, act on the bridge structure at different time and in different combinations. The magnitudes of the loads also differ from time to time. Thus the loading conditions to which bridge structure is exposed are extremely large. In practice the verification that the limit states are not exceeded is carried out for a limited number of combinations, each of which represents likely condition of bridge loading during its design service life. The load combinations and the partial factors of loads to be considered in that combination are defined in IRC:6. Basically, the following four design situations are considered, depending on the duration of the load and the frequency of occurrence of load combinations.

Persistent Design Situation (Basic Load Combinations)

It is the design situation that is relevant during a period of the same order as the design working life of the structure. Generally it refers to conditions of normal use.

This includes permanent and quasi-permanent loads as well as variable loads like live load, wind, hydraulic loads like water current buoyancy etc.

Transient Design Situation

It is the design situation that is relevant during a period much shorter than the design working life of the structure but which has a high probability of occurrence.

A transient design situation refers to temporary conditions of the structure, of use, or exposure, such as those arising during construction or when restrictions are put on its use.

Accidental Design Situation

It is the design situation involving exceptional conditions of the structure or its exposure, including fire, explosion, impact or local failure.

For concrete bridge structures, vehicle impact load is usually considered. The fire hazard or explosion pressures, if specified, (e.g. as in case of material storage or human occupancy below city flyovers) shall be based on the Indian Standards specifying fire resistance (as per IS 456, IS 1641 and IS 1642) and blast resistance (as per IS 4991).

Seismic Design Situation

It is the design situation involving exceptional conditions of the structure when subjected to a seismic event.

Generally, it is not economical to design bridge structure to remain within elastic limits when subjected to 'Design Basis Earthquake' which is defined in IRC:SP:114. Parts of the bridge structure are permitted to suffer damage during the design event. At higher level of seismic event, the bridge elements are expected to suffer large but repairable damage without failure or collapse. Presently, IRC:SP:114 is specifying force-based design methods, which are deemed to achieve the aim of satisfactory performance.

Since the structural behaviour of the bridge under seismic conditions is completely different (i.e. non-elastic response is considered) from the response to other loads (which are essentially in elastic range), the seismic situations are separately treated.

A1-4 Limit States to be Considered

(1) Limit States of Strength (ULS)

Three limit states are checked:

- (i) Stability of overall structure or its elements,
- (ii) Failure of members or the whole structure by buckling of its elements,
- (iii) Failure of member at its critically loaded section under action of axial force, bending moment, shear, and torsion.

(2) Limit States of Serviceability (SLS)

Following limit states of serviceability are covered in this Code:

- (i) Limit state of stresses
- (ii) Limit state of deformation (deflection)

(iii) Limit state of crack width

Other limit states such as limit state of vibration and limit state of fatigue may be important for some bridge structures. Specialist literature or international standards may be referred for the same.

Different serviceability limit states are governed by different sets of load combinations. The following sets of load combinations are defined in Section 12.

(a) **Rare combinations (also called Characteristic Combination or Infrequent Combination)**

In these situations bridge elements, are subjected to maximum design loads leading to maximum stress levels. These basic combinations are used for checking 'limit state of maximum stress levels' in bridge elements.

(b) **Frequent Combinations**

These represent design situations that occur repeatedly in service.

The maximum allowable deflections, crack width in prestressed elements with bonded tendons (and vibration where specified) are checked for the frequently occurring situation.

(c) **Quasi-Permanent Combinations**

These combinations are used to consider long term action effects. Crack widths in reinforced concrete elements and prestressed elements with unbonded tendons where durability is affected and effects of settlement, creep etc., caused by permanent or more or less permanent actions listed in A-1.2(1), are evaluated with quasi-permanent combinations.

ADDITIONAL INFORMATION AND DATA ABOUT PROPERTIES OF CONCRETE AND STEEL

A2.1 General

Section 6 gives values of various design properties. The co-relations on which these are based are given in the following Sub-sections. Also, the expressions for creep and shrinkage for different types of cements and in different conditions of relative humidity, are given. Effect of high temperature curing, and multi-axial stresses is indicated. High temperature curing also increases the rate of relaxation loss of steel in pre-tensioned precast members. Method of calculating the same is given.

An informative Sub-section is added about partial material factor for concrete, and use of cores taken for measuring in-situ strength of concrete structures. The test results of cores taken from existing structure are also used for retrofitting of old bridges by using probable equivalent design cube strength f_{ck} , few observations on the co-relation between the two are given for guidance of designers.

For more detailed information on these and various other properties of concrete which may be needed for special applications, while still using the general principles of this Code specialist literature may be referred.

A2.2 Co-relation between Compressive Cube Strength and Other Concrete Properties

Table 6.5 gives directly the design properties of concrete in terms of its 28 days compressive (cube) strength. The values are based on the following co-relationships, which are experimentally established. However, the scatter in values is larger than the scatter in cube strengths, since co-relationship is not exact, but is a best fit to actual data.

$$(1) \quad f_{cm} = f_{ck} + 10, \quad f_{cm} \text{ and } f_{ck} \text{ in MPa} \quad \text{Eq. A2-1}$$

$$(2) \quad (i) f_{ctm} = 0.259 (f_{ck})^{2/3} \quad \text{For } f_{ck} \leq 60 \text{ MPa} \quad \text{Eq. A2-2}$$

$$(ii) f_{ctm} = 2.27 \ln[1+(f_{cm}/12.5)] \quad \text{For } f_{ck} > 60 \text{ MPa}$$

$$(3) \quad f_{ctk;0,05} = 0.7 f_{ctm}, \quad f_{ctk;0,05} \text{ is 5\% fractile} \quad \text{Eq. A2-3}$$

$$(4) \quad f_{ctk;0,95} = 1.3 \times f_{ctm}, \quad f_{ctk;0,95} \text{ is 95\% fractile} \quad \text{Eq. A2-4}$$

$$(5) \quad E_{cm} = 22 \left(\frac{f_{cm}}{12.5} \right)^{0.3}, \quad E_{cm} \text{ in GPA} \quad \text{Eq. A2-5}$$

$$(6) \quad \varepsilon_{cl} (0/00) = 0.653x (f_{cm})^{0.31} < 2.8 \quad \text{Eq. A2-6}$$

$$(7) \quad \varepsilon_{cu1} (0/00) = 2.8 + 27 \left[\frac{98 - 0.8 f_{cm}}{100} \right]^4 \quad \text{for } f_{ck} > 60 \text{ MPa} \quad \text{Eq. A2-7}$$

$$(8) \quad \varepsilon_{c2} (0/00) = 2.0 + 0.085(0.8 f_{ck} - 50)^{0.53} \quad \text{for } f_{ck} > 60 \text{ MPa} \quad \text{Eq. A2-8}$$

$$(9) \quad \varepsilon_{cu2}({}^0/_{00}) = 2.6 + 35 \left[\frac{90 - 0.8f_{ck}}{100} \right]^4 \quad \text{for } f_{ck} > 60 \text{ MPa} \quad \text{Eq. A2-9}$$

$$(10) \quad n = 1.4 + 23.4 \left[\frac{90 - 0.8f_{ck}}{100} \right]^4 \quad \text{for } f_{ck} > 60 \text{ MPa} \quad \text{Eq. A2-10}$$

$$(11) \quad \varepsilon_{c3}({}^0/_{00}) = 1.75 + 0.55 \left[\frac{0.8f_{ck} - 50}{40} \right] \quad \text{for } f_{ck} > 60 \text{ MPa} \quad \text{Eq. A2-11}$$

$$(12) \quad \varepsilon_{cu3}({}^0/_{00}) = 2.6 + 35 \left[\frac{90 - 0.8f_{ck}}{100} \right]^4 \quad \text{for } f_{ck} > 60 \text{ MPa} \quad \text{Eq. A2-12}$$

A2.3 Development of Strength with Time

(1) Gain of strength with time

Equations given in Clause 6.4.2.2 are valid for concretes made from ordinary Portland Cements. For other types of cements mentioned in Section 18, the value of ‘S’ in equations may be modified as follows :

S = 0.2 for rapid hardening high strength cements.

= 0.38 for slow hardening cement.

A2.4 Effect of High Temperature on Strength (Clause 6.4.2.2)

In case of heat curing the compressive strength of concrete at age ‘t’ before 28 days, $f_{cm}(t)$ may be estimated from expression 6.2 & 6.3 in which the concrete age ‘t’ is substituted by temperature adjusted concrete age (maturity) obtained from Eq. A2-13.

The effect of elevated or reduced temperatures within the range 0 - 80°C on the maturity of concrete may be taken into account by adjusting the concrete age according to the following expression:

$$t_T = \sum_{i=1}^n \Delta t_i \exp \left[13.65 - \frac{4000}{273 + T_{(\Delta t_i)} / t_o} \right] \quad \text{Eq. A2-13}$$

Where

t_T = is the temperature adjusted concrete age which replaces time t in the corresponding equations.

$T(\Delta t_i)$ = is the temperature in °C during the time period Δt_i

Δt_i = is the number of days where a temperature T prevails.

t_o = 1°C

A2.5 Basic Equations for Creep Co-Efficient

(1) The creep coefficient $\phi(t, t_o)$ may be calculated from:

$$\phi(t, t_o) = \phi_o \beta_c(t, t_o)$$

Eq. A2-14

where

$$\phi_o = \phi_{RH} \beta(f_{cm}) \cdot \beta(t_o)$$

Eq. A2-15

ϕ_{RH} is a factor to allow for the effect of relative humidity on the notional creep coefficient.

$$\phi_{RH} = 1 + \frac{1 - RH/100}{0.1 \sqrt[3]{h_o}} \text{ for } f_{cm} \leq 45 \text{ MPa}$$

Eq. A2-16

$$\phi_{RH} = \left[1 + \frac{1 - RH/100}{0.1 \sqrt[3]{h_o}} \alpha_1 \right] \alpha_2 \text{ for } f_{cm} > 45 \text{ MPa}$$

Eq. A2-17

RH is average of relative humidity (RH) of atmosphere

$\beta(f_{cm})$ is a factor to allow for the effect of concrete strength on the notional creep coefficient.

$$\beta(f_{cm}) = \frac{18.78}{\sqrt{f_{cm}}}$$

Eq. A2-18

f_{cm} is the mean compressive strength of concrete in MPa at the age of 28 days

$\beta(t_o)$ is a factor to allow for the effect of concrete age at loading on the notional creep coefficient.

$$\beta(t_o) = \frac{1}{0.1 + t_o^{0.20}}$$

Eq. A2-19

h_o is the notional size of the member in mm where:

$$h_o = \frac{2A_c}{u}$$

Eq. A2.20

A_c is the cross-sectional area

u is the perimeter of the member in contact with the atmosphere.

$\beta_c(t, t_o)$ is a coefficient to describe the development of creep with time after loading, and may be estimated using the following equation:

$$\beta_c(t, t_o) = \left[\frac{(t - t_o)}{\beta_H + t - t_o} \right]^{0.3}$$

Eq. A2-21

t is the age of concrete in days at the moment considered.

t_o is the age of concrete at loading in days.

$t - t_o$ is the non-adjusted duration of loading in days.

β_H is a coefficient depending on the relative humidity (RH in percent) and the notional member size (h_o in mm), it may be estimated from:

$$\beta_H = 1.5 [1 + (0.012RH)^{18}] h_o + 250 \leq 1500 \text{ for } f_{cm} \leq 45 \text{ MPa}$$

Eq. A2-22

$$\beta_H = 1.5[1 + (0.012RH)^{18}] h_o + 250 \alpha_3 \leq 1500 \alpha_3 \text{ for } f_{cm} > 45 \text{ MPa} \quad \text{Eq. A2-23}$$

$\alpha_{1/2/3}$ are coefficients to consider the influence of the concrete strength:

$$\alpha_1 = \left[\frac{43.75}{f_{cm}} \right]^{0.7} \quad \alpha_2 = \left[\frac{43.75}{f_{cm}} \right]^{0.2} \quad \alpha_3 = \left[\frac{43.75}{f_{cm}} \right]^{0.5} \quad \text{Eq. A2-24}$$

The effect of type of cement on the creep coefficient of concrete may be taken into account by modifying the age of loading to in Eq. (A2-19) according to Eq. A2-25.

$$t_o = t_{o,T} \left(\frac{9}{2 + t_{o,T}^{1.2}} + 1 \right)^\alpha \geq 0.5 \quad \text{Eq. A2-25}$$

where

$t_{o,T}$ is the temperature adjusted age of concrete at loading in days adjusted according to Eq. A2-13.

α is a power which depends on type of cement.

= -1 for slow setting cement.

= 0 for Normal cement.

= 1 for Rapid hardening cement.

(2) The mean coefficient of variation of the above predicted creep data deduced from a computerised data bank of laboratory test results is of the order of 20 percent.

A2.6 Basic Equations for Determining the Drying Shrinkage Strain

The basic drying shrinkage strain $\varepsilon_{cd,0}$ is calculated from:

$$\varepsilon_{cd,0} = 0.85 \left[(220 + 110 \alpha_{ds1}) \cdot \exp \left(-\alpha_{ds2} \cdot \frac{f_{cm}}{f_{cmo}} \right) \right] \cdot 10^{-6} \cdot \beta_{RH} \quad \text{Eq. A2-26}$$

$$\beta_{RH} = 1.55 \left[1 - \left(\frac{RH}{RH_o} \right)^3 \right] \quad \text{Eq. A2-27}$$

where

f_{cm} is the mean compressive strength (MPa)

f_{cmo} = 12.5 MPa

α_{ds1} is a coefficient which depends on the type of cement.

= 3 for slow setting cement.

= 4 for Normal cement.

= 6 for rapid hardening.

α_{ds2} is a coefficient which depends on the type of cement.

= 0.13 for slow setting cement.

= 0.12 for Normal cement.

= 0.11 for rapid hardening cement.

RH is average of relative humidity (RH) of atmosphere)

RH_o = 100 percent.

A2.7 Stress-strain Relation for Non-Linear Structural Analysis

The relation between σ_c and ε_c shown in **Fig. A2-1** (compressive stress and shortening strain shown as positive values) for short term uni-axial loading is described by the Equation below:

$$\frac{\sigma_c}{f_{cm}} = \frac{k\eta - \eta^2}{1 + (k-2)\eta} \quad \text{Eq. A2-28}$$

where

$$\eta = \frac{\varepsilon_c}{\varepsilon_{cl}}$$

ε_{cl} is the strain at peak stress according to **Table 6.5**.

$$k = 1.05 E_{cm} \times \varepsilon_{cl} / f_{cm}$$

The above equation A2-28 is valid for $0 < \varepsilon_c < \varepsilon_{cul}$. Where ε_{cl} is the nominal ultimate strain.

Other idealised stress-strain relations may be used, if they adequately represent the behaviour of the concrete considered.

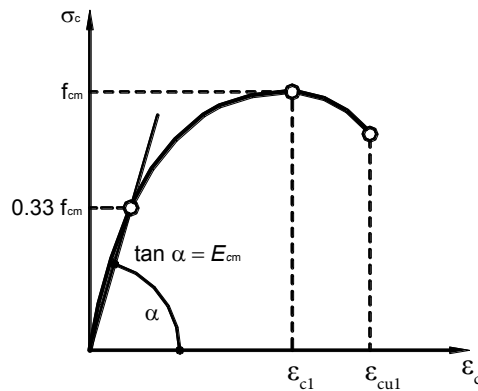

Note: The use $0.33 f_{cm}$ for the definition of E_{cm} is approximate

Fig. A2-1 Schematic Representation of the Stress-Strain Relation for Structural Analysis

A2.8 Multi-Axial Stresses

Confinement of concrete results in higher strength and higher critical strains. As a result stress-strain relationship is modified. The other basic material characteristics may be considered as unaffected for design.

In the absence of more precise data, the stress-strain relationship shown in **Fig. A2.2** may be used, with increased characteristic strength and strains as given below:

$$f_{ck,c} = f_{ck}(1+5\sigma_2/f_{ck}) \text{ for } \sigma_2 \leq 0.05 f_{ck} \tag{Eq. A2-29}$$

$$f_{ck,c} = f_{ck}(1.125+2.5\sigma_2/f_{ck}) \text{ for } \sigma_2 > 0.05 f_{ck} \tag{Eq. A2-30}$$

$$\epsilon_{c2,c} = \epsilon_{c2} (f_{ck,c}/f_{ck})^2 \tag{Eq. A2-31}$$

$$\epsilon_{cu2,c} = \epsilon_{cu2} + 0.2\sigma_2/f_{ck} \tag{Eq. A2-32}$$

Where $\sigma_2 (= \sigma_3)$ is the effective lateral compressive stress at the ULS due to confinement and ϵ_{c2} and ϵ_{cu2} follow from **Table 6.5**. Confinement can be achieved by adequately closed links or cross-ties, which reach the plastic condition due to lateral extension of the concrete.

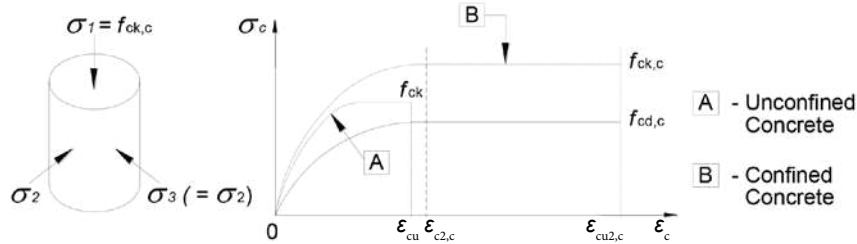

Fig. A2-2 Stress-Strain Relationship for Confined Concrete

A2.9 Other Simplified Stress-Strain Relationship for Design of Cross- Section (Section 6.4.3.8)

- (1) Other simplified stress-strain relationships may be used if they are equivalent to or more conservative than the one defined in Section 6.4.3.8., such as Bi-linear stress-strain diagram as per **Fig. A2-3** (compressive stress and strain shown as positive values) is with values of ϵ_{c3} and ϵ_{cu3} according to **Table 6.5**.

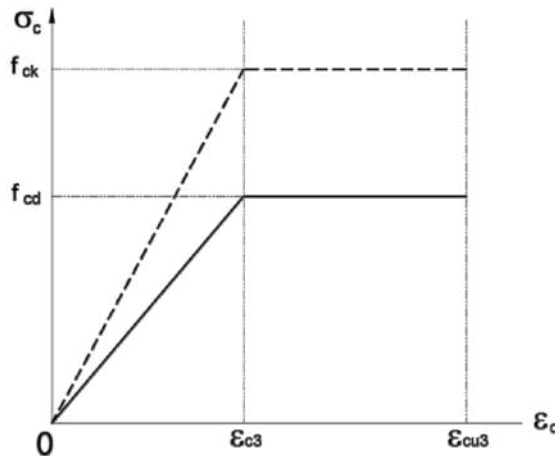

Fig. A2-3 Bi-Linear Stress-Strain Relation

- (2) A rectangular stress distribution (as given in **Fig. A2.4**) may be assumed. The factor λ , defining the effective height of the compression zone and the factor η defining the effective strength, follow from:

$$\lambda = 0.8 \quad \text{for } f_{ck} \leq 60 \text{ MPa} \tag{Eq. A2-33}$$

$$\lambda = 0.8 - (f_{ck} - 60) / 500 \text{ for } 60 < f_{ck} \leq 110 \text{ MPa} \tag{Eq. A2-34}$$

and

$$\eta = 1.0 \quad \text{for } f_{ck} \leq 60 \text{ MPa}$$

Eq. A2-35

$$\eta = 1.0 - (f_{ck} - 60)/250 \quad \text{for } 60 < f_{ck} \leq 110 \text{ MPa}$$

Eq. A2-36

Note: If the width of the compression zone decreases in the direction of the extreme compression fibre, the value ηf_{cd} should be reduced by 10 percent.

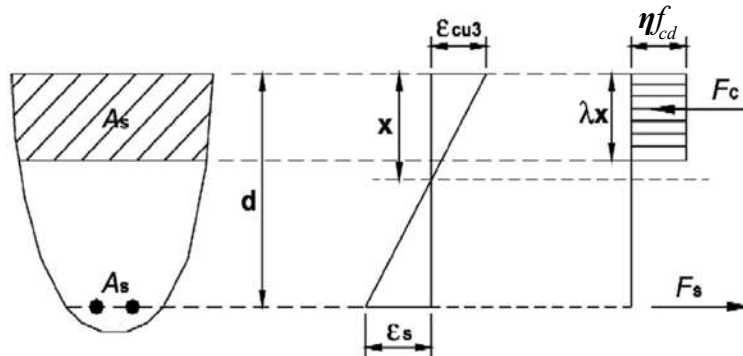

Fig. A2-4 Rectangular Stress Distribution

A2.10 Partial Safety Factor γ_c for Concrete

The material partial factor γ_c of concrete includes consideration of various factors as described below.

Partial material safety factor γ_c which is considered to have a value of 1.5, consists of two parts.

The first part is the factor $\gamma_M = \gamma_{M1} \cdot \gamma_{M2} = 1.3$, which considers unfavourable deviation of concrete strength from its characteristic value f_{ck} , model uncertainties, variation of geometrical properties and overall safety level. It is based on log-normal distribution:

$$\gamma_M = \exp [\alpha_R \cdot \beta \cdot V_R - 1.645 V_R] \quad \text{Eq. A2-37}$$

with

$\alpha_R = 0.8$ Sensitivity factor for resistance.

$\beta = 3.8$ Reliability index (used for targeting desired level of non-occurrence of failure at ULS in this Code).

$$V_R = \sqrt{(V_m^2 + V_G^2 + V_f^2)}$$

$V_f = 0.15$ coefficient of variation of material properties.

$V_m = 0.05$ coefficient of variation of model uncertainties.

$V_G = 0.05$ coefficient of variation of geometrical properties.

Consequently the part of γ_M which represents the variability of material properties is:

$$\gamma_{M1} = \exp [\alpha_R \beta V_f] = 1.23$$

The part γ_{M2} represents the variation of geometrical properties and model uncertainties:

$$\gamma_{M2} = \frac{\gamma_M}{\gamma_{M1}} = \frac{1.30}{1.23} = 1.05$$

second part of γ_c is a conversion factor $\gamma_{conv} = 1.15$, used with cylindrical strength which takes into account the decrease of in-place strength versus the characteristic strength f_{ck} . In the literature the inverse value of 0.85 often is used. (This factor for use with cube strength becomes 0.67). The mean values of concrete compressive strength controlled at plant and the mean value of in-situ concrete compressive strength are approximately of the same magnitude for the concrete age at 28 days. But due to other effects, such as transportation temperature changes, placing, compaction and curing, the variation of insitu concrete strength is essentially larger (coefficient of variation is about 0.23) than the variation of strength of concrete at plant (coefficient of variation is about 0.13). Therefore, the safety factor $\gamma_M = 1.3$ is not adequate to cover this increase of variation and additional factor should be used

γ_{conv} . To find this additional factor the in-situ strength, or a ratio $\frac{f_s}{f_{ck}}$ was evaluated. In-situ strength of concrete was considered as a random variable (log-normally distributed). Based on the German and Canadian data the 5 percent fractile of this ratio was found as a value of 0.90 for columns and walls and as a value of 0.83 for slabs and beams. These results corroborate the use of $\gamma_{conv} = 1.15$, increasing γ_m from 1.3 to 1.5 which correspond to the factor 0.85 used with the cylinder strength (or 0.67 used with cube strength).

A2.11 Relaxation of Steel

The relaxation loss shall be obtained from the manufacturers test certificates, and verified by independent tests, if required. Relaxation characteristics are dependent on the manufacturing process. In the absence of specific data, for steels conforming to BIS codes, the following relationships may be used for calculation of relaxation loss up to 30 years. The long term loss after 50 years may be taken as three times the 1000 hour loss. Eq. A2-38 is a general equation describing relationship between relaxation loss at time t in hours (ρ_t) and that at 1000 hours (ρ_{1000}). The exponent 'k' in the equation is approximately given by $\log(\rho_{1000} / \rho_{100})$.

$$\rho_t = \rho_{1000} \left[\frac{t}{1000} \right]^k$$

Eq. A2-38

Wires/strands of normal relaxation for which IS 1785 - Part 1, IS 6003, and IS 6006 specify 1000 hour relaxation loss value at not more than 5 percent and 100 hour relaxation loss as not more than 3.5 percent, k is 0.155.

Wires/strands of low relaxation for which IS 14268 specifies 1000 hour relaxation value at not less than 2.5 percent and 100 hour value at not less than 1.8 percent, k is 0.143.

For bars/rods, IS 2090 does not specify 100 hour relaxation loss value. Also 1000 hour relaxation loss value is not expressed as % value. For this reason the applicable strength, ρ_{1000} , ρ_{100} loss values will have to be obtained from the manufacturer's data.

For steels conforming to other national standards reference shall be made to the respective standards.

A2.12 Effect of High Temperature Curing on Relaxation of Steel

For pre-tensioned members, the effect on the relaxation losses of increasing the temperature while curing the concrete, shall be considered.

The relaxation is accelerated during the application of thermal curing when thermal strain is introduced at the same time. Finally, the relaxation rate is reduced at the end of the treatment.

An equivalent time t_{eq} should be added to the time after tensioning ' t ' in the relaxation time functions to cater for the effects of the heat treatment on the prestress loss due to the relaxation of the prestressing steel. This equivalent time can be estimated from the expression:

$$t_{eq} = \frac{1.14^{(T_{max}-20)}}{T_{max}-20} \sum_{i=1}^n (T_{(\Delta t_i)} - 20) \Delta t_i$$

Eq. A2-39

where

t_{eq} is the equivalent time (in hours)

$T(\Delta t_i)$ is the temperature (in °C) during the time interval Δt_i

T_{max} is the maximum temperature (in °C) during the heat treatment.

LIST OF STANDARDS AND OTHER NORMATIVE REFERENCES

(1) List of Bureau of Indian Standards Codes		
Sr. No.	Standard No.	Title
(1)	IS 269 : 2015	Ordinary portland cement Specification
(2)	IS 383 : 2016	Coarse and fine aggregates for concrete
(3)	IS 432 : Part 1 : 1982	Specification for mild steel and medium tensile steel bars and hard-drawn steel wire for concrete reinforcement: Part 1 mild steel and medium tensile steel bars (Third Revision)
(4)	IS 432 Part 2 : 1982	Specification for mild steel and medium tensile steel bars and hard-drawn steel wire for concrete reinforcement:Part-2 hard-drawn steel wire (Third Revision)
(5)	IS 455 : 2015	Specification for Portland slag cement (Fourth Revision)
(6)	IS 456 : 2000	Code of practice for plain and reinforced concrete
(7)	IS 516 : 1959	Method of test for strength of concrete
(8)	IS 822 : 1970	Code of procedure for inspection of welds
(9)	IS 1199 : 1959	Methods of sampling and analysis of concrete
(10)	IS 1343 : 2010	Code of practice for prestressed concrete
(11)	IS 1489 :Part 1 : 2015	Specification for portland pozzolana cement Part-1 Fly Ash based (Third Revision)
(12)	IS 1608 : 1995	Mechanical testing of metals - Tensile Testing (Third Revision)
(13)	IS 1641 : 1988	Code of practice for fire safety of building (General : General principles of fire grading and classification)
(14)	IS 1642 : 1989	Fire safety of building (General : Details of construction - Code of Practice)
(15)	IS 1765 : 1980	Direct current potentiometers (Second Revision)
(16)	IS 1785 : Part 1 : 1983	Specification for Plain Hard-drawn Steel Wire for Prestressed Concrete - Part 1 : Cold Drawn Stress-relieved Wire (Second Revision)
(17)	IS 1786 : 2008	Specification for high strength deformed steel bars and wires for concrete reinforcement (Third Revision)
(18)	IS 2090 : 1983	Specification for high tensile steel bars used in prestressed concrete (First Revision)
(19)	IS 2386 : Part 1 : 1963	Methods of test for Aggregates for Concrete - Part 1 : Particle Size and Shape
(20)	IS 2386 : Part 2 : 1963	Methods of test for Aggregates for Concrete - Part 2 : Estimation of deleterious materials and organic impurities
(21)	IS 2386 : Part 3 : 1963	Methods of test for Aggregates for Concrete - Part 3 : Specific gravity, density, voids, absorption and bulking

(1) List of Bureau of Indian Standards Codes		
Sr. No.	Standard No.	Title
(22)	IS 2386 : Part 4 : 1963	Methods of test for Aggregates for Concrete - Part 4 : Mechanical properties
(23)	IS 2386 : Part 5 : 1963	Methods of test for Aggregates for Concrete - Part 5 : Soundness
(24)	IS 2386 : Part 6 : 1963	Methods of test for Aggregates for Concrete - Part 6 : Measuring mortar making properties of fine aggregates
(25)	IS 2386 : Part 7 : 1963	Methods of test for Aggregates for Concrete - Part 7 : Alkali Aggregate Reactivity
(26)	IS 2386 : Part 8 : 1963	Methods of test for Aggregates for Concrete - Part 8 : Petrographic Examination
(27)	IS 2751 : 1979	Code of practice for Welding of Mild Steel Plain and Deformed Bars For Reinforced Concrete Construction (First Revision)
(28)	IS 3025 : Part 17:1984	Methods of sampling and test (Physical and chemical) for water and wastewater : Part 17 : Non-filterable residue (Total suspended solids) (First Revision)
(29)	IS 3025 : Part 18:1984	Methods of sampling and test (Physical and Chemical) for water and wastewater : Part 18 : Volatile and fixed residue (Total filterable and non-filterable) (First Revision)
(30)	IS 3025 : Part 22:1986	Methods of sampling and test (Physical and Chemical) for water and wastewater : Part 22 : Acidity (First Revision)
(31)	IS 3025 : Part 23:1986	Methods of sampling and test (Physical and Chemical) for water and wastewater : Part 23 : Alkalinity (First Revision)
(32)	IS 3025 : Part 28:1986	Methods of sampling and test (Physical and Chemical) for water and wastewater : Part 28 : Sulphite (First Revision)
(33)	IS 3025 : Part 32:1986	Methods of sampling and test (Physical and Chemical) for water and wastewater : Part 32 : Chloride (First Revision)
(34)	IS 3812 : Part 1 : 2003	Pulverized Fuel Ash - Specification - Part 1 : For use as Pozzolana in Cement, Cement Mortar and Concrete (Second Revision)
(35)	IS 3812 : Part 2 : 2003	Pulverized Fuel Ash - Specification - Part 2 : For use as Admixture in Cement mortar and Concrete (Second Revision)
(36)	IS 4031 : Part 5 : 1988	Methods of physical tests for hydraulic cement : Part 5 : Determination of initial and final setting times (First Revision)
(37)	IS 6003 : 1983	Specification for indented wire for prestressed concrete (First Revision)
(38)	IS 6006 : 1983	Specification for uncoated stress relieved strand for prestressed concrete (First Revision)
(39)	IS 8041 : 1990	Specification for rapid hardening portland cement (Second Revision)
(40)	IS 9013 : 1978	Method of making, curing and determining compressive strength of accelerated cured concrete test specimens
(41)	IS 9103 : 1999	Concrete Admixtures - Specification (First Revision)

(1) List of Bureau of Indian Standards Codes		
Sr. No.	Standard No.	Title
(42)	IS 9417 : 1989	Recommendations for welding cold worked bars for reinforced concrete construction (First Revision)
(43)	IS 12089 : 1987	Specification for granulated slag for manufacture of Port land slag cement
(44)	IS 12330 : 1988	Specification for sulphate resisting Portland cement
(45)	IS 12594 : 1988	Hot-dip Zinc Coating on Structural Steel Bars for Concrete Reinforcement – Specification
(46)	IS 13311 : Part 1:1992	Non-destructive testing of concrete : Part 1 : Ultrasonic pulse velocity
(47)	IS 13311 : Part 2:1992	Non-destructive testing of concrete : Part 2 : Rebound hammer
(48)	IS 13600 : 1989	Specification for low heat portland cement
(49)	IS 13620 : 1993	Specification for fusion bonded epoxy coated reinforcing bars
(50)	IS 14268 : 1995	Specification for uncoated stress relieved low relaxation seven ply strand for prestressed concrete
(51)	IS 14959 : Part 1:2001	Determination of water soluble and acid soluble chlorides in mortar and concrete - method of test : Part 1 : Fresh Mortar and Concrete
(52)	IS 14959 : Part 2:2001	Determination of water soluble and acid soluble chlorides in mortar and concrete - method of test : Part 2 : Hardened Mortar and Concrete
(53)	IS 15388 : 2003	Silica Fume – Specification

(2) List of ASTM Standards		
Sr. No.	Standard No.	Title
(1)	C156-09a	Standard Test Method for Water Loss [from a Mortar Specimen] Through Liquid Membrane-Forming Curing Compounds for Concrete
(2)	C171-07	Standard Specification for Sheet Materials for Curing Concrete
(3)	C309-07	Standard Specification for Liquid Membrane-Forming Compounds for Curing Concrete
(4)	C803/C803M-03(2010)	Standard Test Method for Penetration Resistance of Hardened Concrete
(5)	C900-06	Standard Test Method for Pullout Strength of Hardened Concrete
(6)	C939-10	Standard Test Method for Flow of Grout for Preplaced- Aggregate Concrete (Flow Cone Method)
(7)	C1074-10	Standard Practice for Estimating Concrete Strength by the Maturity Method
(8)	C1090-10	Standard Test Method for Measuring Changes in Height of Cylindrical Specimens of Hydraulic-Cement Grout
(9)	C1202-10	Standard Test Method for Electrical Indication of Concrete's Ability to Resist Chloride Ion Penetration

(3) List of British Standards		
Sr. No.	Standard No.	Title
(1)	BS: 1881 : Part 5	Testing Concrete – Methods of Testing Hardened Concrete other than Strength
(2)	BS:6744	Specifications for Austenitic Stainless Steel Bars for the Reinforcement of Concrete

(4) List of DIN Standards		
Sr. No.	Standard No.	Title
(1)	DIN: 1048 : Part 5	Testing Concrete – Testing of Hardened Concrete (Specimen Prepared in Mould)

TESTS ON MILD STEEL & CORRUGATED HDPE SHEATHING DUCTS

1.0 FOR MILD STEEL SHEATHING DUCTS

All tests specified below shall be carried out on the same sample in the order given below. At least 3 samples for one lot of supply (not exceeding 7000 metre length) shall be tested.

1.1 Workability Test

A test sample 1100 mm long is soldered to a fixed base plate with a soft solder (Fig. A5-1). The sample is then bent to a radius of 1800 mm alternately on either side to complete 3 cycles.

Thereafter, the sealing joints will be visually inspected to verify that no failure or opening has taken place.

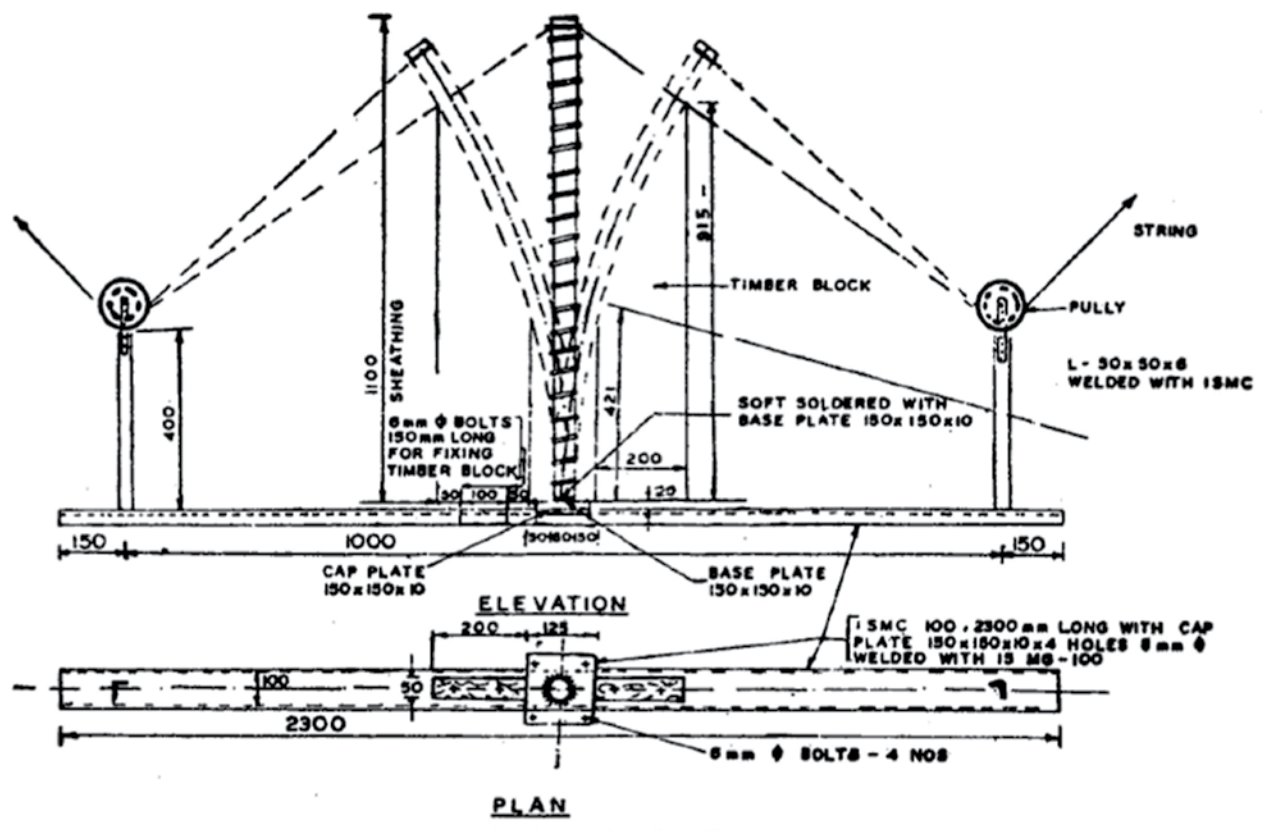

Fig. A5-1. Workability Test

1.2 Transverse Load Rating Test

The test ensures that stiffness of the sheathing is sufficient to prevent permanent distortion during site handling.

The sample is placed on a horizontal support 500 mm long so that the sample is supported at all points of outward corrugations.

A load as specified in **Table-A5-1** below is applied gradually at the centre of the supported portion through a circular contact surface of 12 mm dia. Couplers shall be placed so that the load is applied approximately at the centre of two corrugations, **Fig. A5-2**. The load as specified below is applied in increments.

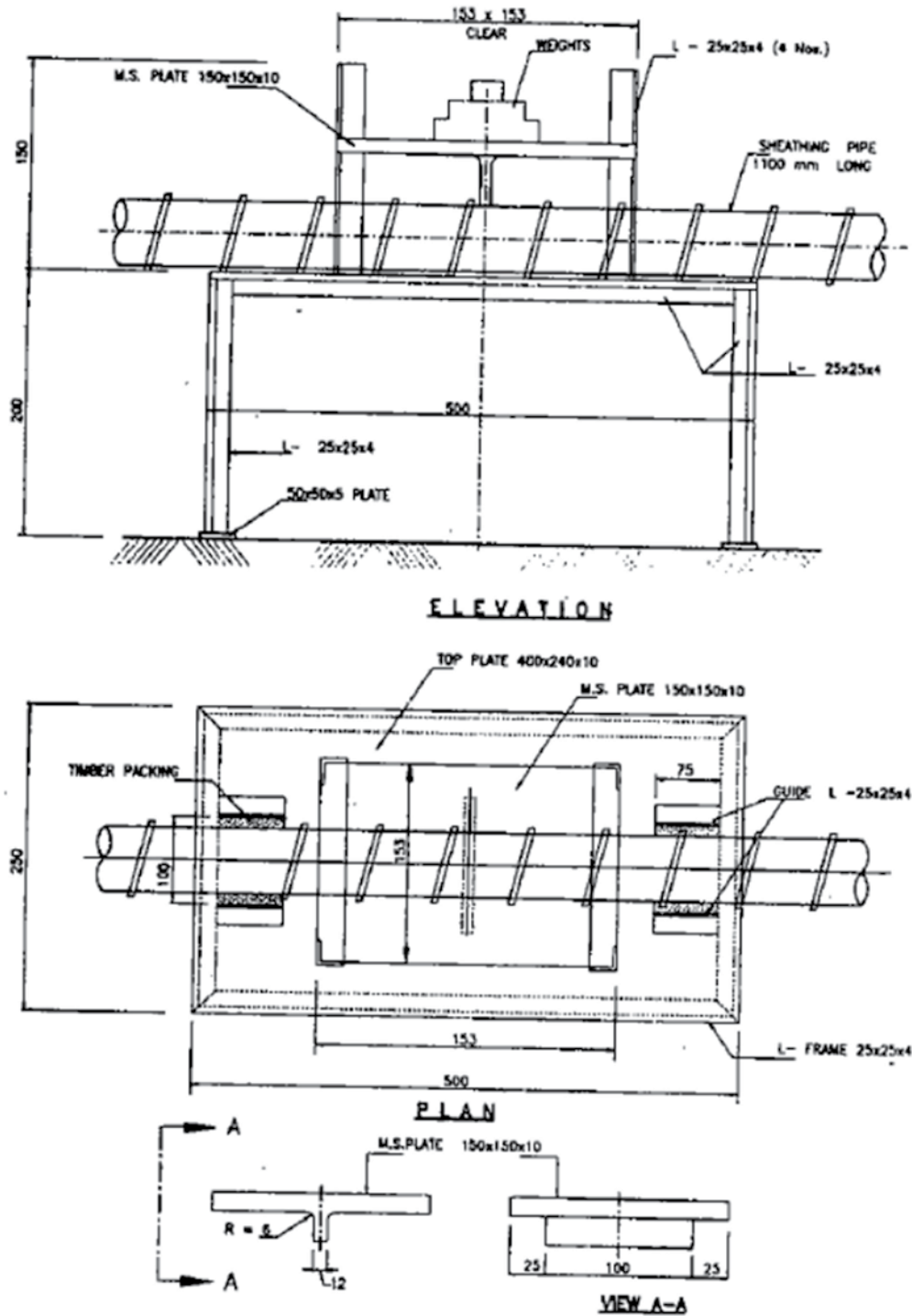

Fig. A5-2 Transverse Load Rating Test

Table A5-1 Table showing Duct Diameter-Test Load relationship

	Between	more than	more than	more than	more than	more than	more than
Dia:	25 mm	35 mm	45 mm	55 mm	65 mm	75mm	85 mm
	to	up to	up to	up to	up to	up to	up to
	35 mm	45 mm	55 mm	65 mm	75 mm	85 mm	90 mm
Load:	250 N	400 N	500 N	600 N	700 N	800 N	1000 N

The sample is considered acceptable if the permanent deformation is less than 5 per cent of the original diameter.

1.3 Tension Load Test

The test specimen is subjected to a tensile load. The hollow core is filled with a wooden circular piece having a diameter of 95 per cent of the inner dia of the sample to ensure circular profile during test loading, **Fig. A5-3**.

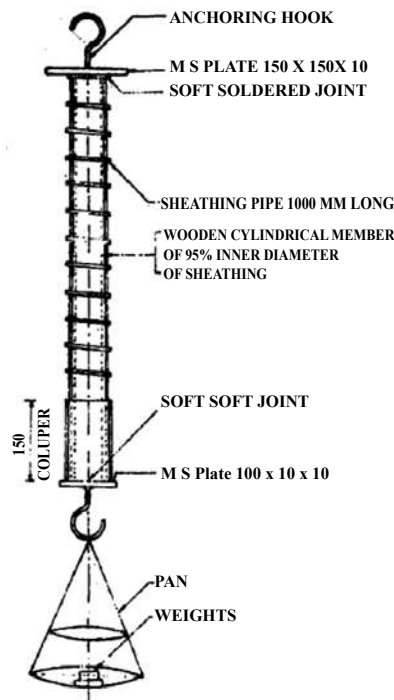

Fig. A5-3. Tension Load Test

A coupler is screwed on and the sample loaded in increments, till specified load. If no deformation of the joints nor slippage of couplers is noticed, the test shall be considered satisfactory:

Dia in mm	Load
25 upto 35	300 N
More than 35 upto 45	500 N
More than 45 upto 55	800 N
More than 55 upto 65	1100 N
More than 65 upto 75	1400 N
More than 75 upto 85	1600 N
More than 85 upto 90	1800 N

1.4 Water Loss Test

The sample is sealed at one end. The sample is filled with water and after sealing, the end is connected to a system capable of applying a pressure of 0.05 MPa, Fig. A5-4 and kept constant for 5 minutes, hand pump and pressure gauge or stand pipe system can be used.

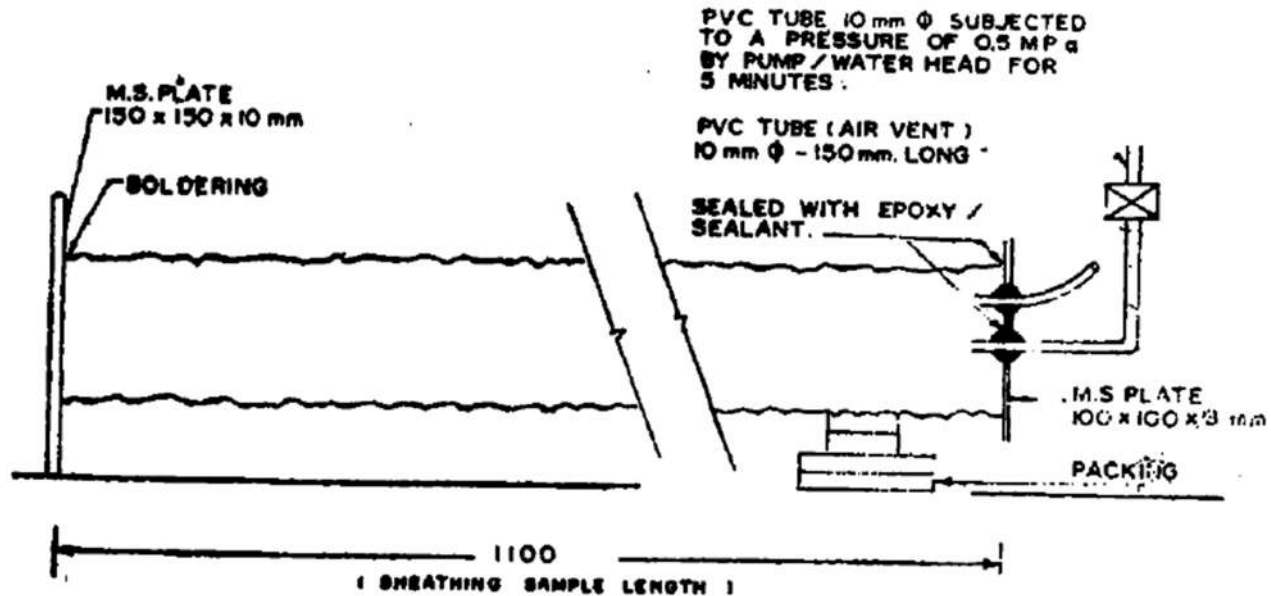

Fig. A5-4 Water Loss Test

The sample is acceptable if the water loss does not exceed 1.5 per cent of the volume. The volume is worked out as follows:

Another sample 500 mm long is sealed at one end and the volume of hollow space arrived at by pouring water from a measuring cylinder.

The computation of relative profile volume is worked out as follows:

V_a - Premeasured quantity of water in measuring cylinder

V_b - Balance quantity of water left in the cylinder after completely filling of the test sample

Actual Volume ' V_p ' = $V_a - V_b$

Relative Profile Volume = $V_p - (\pi\phi^2l/4)/(\pi\phi l) \text{ cm}^3/\text{cm}^3$

Where l is length of specimen and ϕ is internal nominal dia. of sheathing.

1.5 Specification for Sheathing Duct Joints

The sheathing ducts shall be of the spiral corrugated type. For major projects, the sheathing ducts should preferably be manufactured at the project site utilising appropriate machines. With such an arrangement, long lengths of sheathing ducts may be used with consequent reduction in the number of joints and couplers.

Where sheathing duct joints are unavoidable, such joints shall be made cement slurry tight by the use of corrugated threaded sleeve couplers which can be tightly screwed on to the outer side of the sheathing ducts. A heat-shrink coupler could also be used if suitable.

Typical details of a sleeve coupler is shown in **Fig. A5-5**. The length of the coupler should not be less than 150 mm but should be increased upto 200 mm wherever practicable. The joints between the ends of the coupler and the duct shall be sealed with adhesive sealing tape to prevent penetration of cement slurry during concreting. The couplers of adjacent ducts should be staggered wherever practicable. As far as possible, couplers should not be located in curved zones. The corrugated sleeve couplers are being conveniently manufactured using the sheath making machine with the next higher size of die set.

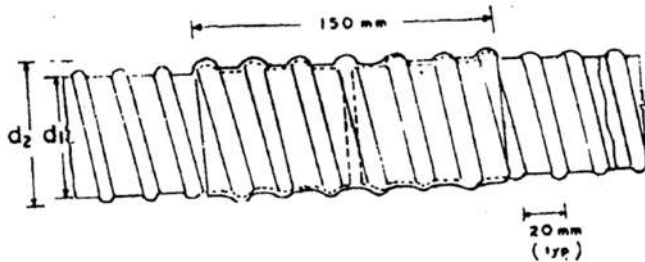

Fig. A5-5 TYPICAL DETAIL OF SLEEVE COUPLER

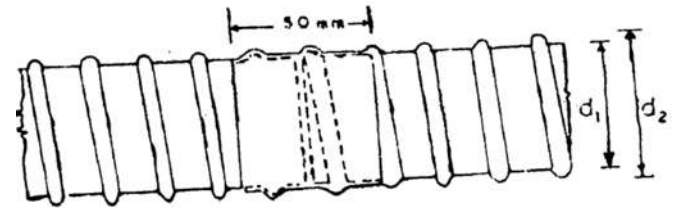

Fig. A5-6 TYPICAL DETAIL OF HEAT SHRINK COUPLER

The heat-shrink coupler **Fig. A5-6** is supplied in the form of bandage rolls which can be used for all diameters of sheathing ducts. The bandage is coated on the underside with a heat sensitive adhesive so that after heating the bandage material shrinks in to the sheathing and ensures formation of a leak proof joint, without the need for extra taping or support in the form of corrugated sleeve couplers. The heating is effected by means of a soft gas flame.

2.0 For Corrugated HDPE Sheathing Ducts

A summary of all the requirements, methods of verification, and acceptance criteria for the polymer duct system together with the components and material is given in **Table A5-2** below. The Table is in line with the technical report Bulletin 75 published by Fib titled “Polymer – duct systems for internal bonded post-tensioning”.

Table A5-2 : Summary of requirements, methods of verification and acceptance criteria for polymer-duct systems - Recommended specification

Sr. No.	Requirement	Relevant Clause No. of Bulletin No. 75, fib	Method of verification	Acceptance criteria	Frequency of Test
Material	2	3	4	5	6
1	Material requirements	5.2 Table 5.2	Material certificates based on testing Test reports Specified properties Declared material properties	Material to comply with certificates, specified properties, and declared properties	As specified in footnote of Table 5.2 of fib75
Components					
2	Dimensional requirements	6.1 Annex A.1	Data sheets Assembly drawings Fabrication drawings	<ul style="list-style-type: none"> - Existence of data sheets - Existence of assembly drawings - Existence of fabrication drawings - Dimensions and tolerances of actual components to comply with specified dimensions and tolerances 	<ul style="list-style-type: none"> a) Initially, b) When there is a change in design c) For each type of material used
3	Stiffness of duct	6.2 Annex A.2	Stiffness test of duct: - at room temperature 23 °C - at high temperature 45 °C	<ul style="list-style-type: none"> -Actual flexural stiffness of duct determined in test -Maximum duct support spacing calculated according to Section 6.2 with actual flexural stiffness such as to limit duct deflection between supports under defined load 	<ul style="list-style-type: none"> a) Initially, b) When there is a change in design c) For each type of material used
4	Longitudinal load resistance of duct	6.3 Annex A.3	Longitudinal load resistance test of duct - at room temperature 23 °C	<ul style="list-style-type: none"> -Prefabricated and on-site fabricated tendon/duct systems to sustain imposed deformation caused by temperature variation of 40 °C -Prefabricated tendon/duct systems to sustain in addition specified minimum longitudinal force for coiling 	<ul style="list-style-type: none"> a) Initially, b) When there is a change in design c) For each type of material used d) When a new connector is proposed for use

1	2	3	4	5	6
5	Lateral load resistance of duct	6.4 Annex A.4	Lateral load resistance test of duct -at room temperature 23 °C -at high temperature 45 °C	-No transverse deformation exceeding 35% at specified transverse load for immediate duct deformation -No transverse deformation exceeding 10% or 5 mm after release of transverse load	a) Initially, b) When there is a change in design c) For each type of material used
6	Flexibility of duct system	6.5 Annex A.5	Flexibility test of duct system -at room temperature 23 °C -at low temperature -15 °C -at high temperature 45 °C	-No visual damage to duct or connector -No deformation of cross section > 5%	a) Initially, b) When there is a change in design c) For each type of material used d) When a new connector is proposed for use
7	Leak tightness of duct system	6.6 Annex A.6	Leak tightness test of duct system -at room temperature 23°C	-Leak tight for tendons (5minutes)	a) Initially, b) When there is a change in design c) For each type of material used d) When a new connector is proposed for use
8	Concrete pressure on duct	6.7 Annex A.7	Concrete pressure test on duct -at room temperature 23 °C	-Deformation of duct cross section when bent to minimum radius of curvature for field installation ≤ 10% under negative pressure of 0.75 bar or 0.25 bar for Class I or Class II, respectively	a) Initially, b) When there is a change in design c) For each type of material used
9	Wear resistance of duct	6.8 Annex A.8	Wear resistance test of duct -at room temperature 23 °C -at high temperature 45 °C	-Residual wall thickness of duct ≥ 1.5 mm for tendons	a) Initially, b) When there is a change in design c) For each type of material used
10	Wear resistance of duct under sustained load	6.9 Annex A.9	Wear of duct under sustained load -at room temperature 23 °C -at high temperature 45 °C	-Residual wall thickness of duct ≥ 1.0 mm for tendons	a) Initially, b) When there is a change in design c) For each type of material used
11	Bond behaviour of duct	6.10 Annex A.10	Bond behaviour test of duct -at room temperature 23 °C	-Transfer 40% UTS of tendons within a length of ≤ 16 duct diameter	a) Initially, b) When there is a change in design c) For each type of material used
12	Precast segmental duct coupler system	6.11 Annex A.11	Precast segmental duct coupler system test -at room temperature 23 °C	- Hold 3.5 bar pressure with ≤ 10% loss in 5 minutes for tendons	a) Initially, b) When there is a change in design c) For each type of material used

1	2	3	4	5	6
13	Fracture resistance of duct (optional if performance is declared by system supplier)	6.12 Annex A.12	Fracture resistance test of duct -at room temperature 23 °C	-No cracking of duct after 2 million cycles of crack opening between 0.2 - 0.5 mm	a) Approval-If declared as option of polymer duct system, this test should be performed as part of the polymer duct system approval. b) Project Specific- If not part of system approval, but required for a specific project.
System					
14	Leak tightness of anchorage-duct assembly	7.1 Annex B.1	Leak tightness test of anchorage -duct assembly -at room temperature 23 °C	-Leak tight for tendons (5minutes)	a) Initially, b) When there is a change in design and/or manufacturing process of polymer ducts, trumpets or connectors, anchorage components. c) For each type of duct material, trumpet and anchorage components used. d) When a new anchorage or trumpet is proposed for use.
15	Full scale duct system assembly	7.4 Annex B.4	Full scale PT and duct system assembly test -at ambient temperature	-Duct profile complies with specified profile -no apparent tendon profile kinks or discontinuities or loss connections -no excessive duct deformations on support or duct deflections between the supports spaced at maximum permissible support spacing as per Section 6.2	a) Initially, b) When a new duct or connector or a new installation method is proposed for use.
16	Leak tightness of assembled duct system	7.5 Annex B.5	Leak tightness test of assembled PT and duct system	-Pressure loss ≤ 10% of initial pressure after 5 minutes for tendons PL2 and PL3	a) Initially, b) When a new duct or connector or a new installation method is proposed for use.

DESIGN CONSIDERATIONS FOR CONSTRUCTION STAGES**A6-1 General**

- (1) For bridges built in stages, the design and detailing shall take into account of the construction procedure, sequence etc., as appropriate. Some situations are illustrated in the following.
 - a) Where forces, other than those produced on the completed structure, occur in any structural section during the phases of construction (e.g. deck erection by incremental launching, bridges built by balanced cantilever, change in sections during construction, change of support conditions during construction etc.).
 - b) Where redistribution of forces due to creep, shrinkage and steel relaxation is originated by changes to the structural arrangement during the construction process (e.g. continuous bridges built span by span on false work or by cantilever).
 - c) Where distribution of stresses due to creep, shrinkage and steel relaxation is originated by changes to structural sections during the construction process (e.g. decks consisting of precast beams and an insitu slab).
 - d) Where the erection or construction sequence may have an influence on the stability of the structure / capacity of section during construction, the forces in the completed structure, or the geometry of the completed structure.
- (2) For structures in which any of the circumstances described in paragraphs (1) a) to d) apply, the serviceability limit states and ultimate limit states should be verified during various construction stages.
- (3) For structures in which the circumstances described in paragraphs (1) b) or c) apply, long term values of forces or stresses should be determined from an analysis of redistribution effects. Step by step or approximate methods may be used in these calculations.
- (4) For structures in which the circumstances described in paragraph (1) d) apply erection and casting sequences / procedures should be indicated on drawings or detailed in a construction procedure document along with assumed construction and equipment loads / configurations etc.

A6-2 Actions & Effects to be considered during construction

For the verifications of equilibrium and limit states during various construction stages following construction loads and erection effects shall be considered.

A6-2.1 General

- (1) Distributed construction live load taken as 50 kg/m² of deck area for cantilever construction, sequential / span by span construction etc.
- (2) Specialized construction equipment load from launching gantry, form traveler, beam and winch, movement of precast segments over constructed portion etc.
- (3) Dynamic load of equipment may be taken as 10% of the lifting load.
- (4) Longitudinal forces arising from construction equipment loads according to the type of the machinery.
- (5) Unbalanced load resulting from sequence / construction stage.
- (6) Horizontal wind load on structure shall be taken in accordance with the provisions of IRC:6 for construction stages.
- (7) Effects arising from imposed deformations shall be taken into account. These effects can be of permanent nature, depending upon the situation. In such situations the strains and stresses shall be algebraically superimposed as per applicable section at various construction stages.
- (8) The support restraints during all construction stages shall be ensured for stability against sliding and overturning. The situation may arise when restraint, particularly in longitudinal direction, may be absent during construction stage. Need of temporary restraint for this situation shall be either accounted for in suggested sequence & detailing or constructor shall be instructed to provide appropriate restraint.

A6-2.2 For cantilever construction

- (1) A differential Dead Load of 2 % on the unfavorable side of the cantilever shall be considered for verification of equilibrium.
- (2) For verification of equilibrium under the accidental combination, dynamic response due to accidental release of precast segment taken as equivalent to additional static load as 100% of the weight of the precast segment.

A6-3 Verification criteria**A6-3.1 Verification for static equilibrium**

The equilibrium of the structure shall be verified for the combinations as per Table B.1 of IRC:6.

A6-3.2 Ultimate limit states

ULS verifications required for design during construction are the same as those given in sections 8, 9, 10 & 11.

A6- 3.3 Serviceability limit states

- (1) Serviceability criteria for the completed structure need not be applied to intermediate construction stages, provided that durability and final appearance of the completed structure are not affected (e.g. crack width and deformations) and comply with applicable provisions of the Code.
 - (2) The idea of frequent combination does not exist during construction and also limit states related to durability are not pertinent for short term-phases as such limiting stresses in concrete to $0.48 f_{ck(t)}$ and steel to $0.8 f_{yk}$ under rare combination during construction is adequate.
 - (3) For bridges or element of bridges in which limit state of decompression is checked on the completed structure, tensile stresses less than $f_{ctm(t)}$ under the quasi permanent combination during construction is permitted.
 - (4) Prestressing effects may be taken as $\gamma_{sup} = \gamma_{inf} = 1.0$ during the construction.
-

Annexure A-7

TABLE A7-1 :STATE-WISE AVERAGE ANNUAL RELATIVE HUMIDITY

(Source: Climatological Normals 1981-2010, issued by Indian Meteorological Department, Pune)

S. No.	Station	Average Annual Relative Humidity (%)		S. No.	Station	Average Annual Relative Humidity (%)	
		I	II			I	II
ANDAMAN & NICOBAR ISLANDS							
1	Car-Nicobar	79	82	28	Tirmalai	76	69
2	Hut Bay	81	82	29	Tirupathy	70	51
3	Kondul	85	86	30	Tuni	74	67
4	Long Island	80	83	31	Vishakhapatnam	73	68
5	Mayabandar	83	83	32	Vishakhapatnam (RS/RW)	73	74
6	Nancowry	81	83	ARUNACHAL PRADESH			
7	Port Blair	77	80	1	Pasighat	77	77
ANDHRA PRADESH/TELENGANA				ASSAM			
1	Anantapur	68	43	1	Dhubri (Rupsi){A}	80	73
2	Arogyavaram	72	48	2	Dibrugarh / Mohanbari (A)	80	76
3	Bapatla	80	67	3	Gauhati(A) (Bhorjar)	81	72
4	Bhadrachallam	78	60	4	North Lakhimpur	80	78
5	Cuddapah	67	49	5	Rangia	77	-
6	Dolphine Nose/CDR Visakhapatnam	78	-	6	Silchar	85	73
7	Gannavaram(A)	78	59	7	Tezpur	81	74
8	Hanamkonda	72	61	BIHAR			
9	Hyderabad(A)	68	46	1	Bhagalpur	78	65
10	Kakinada	77	66	2	Chaibasa	68	54
11	Kalingapatnam	80	77	3	Chapra	74	58
12	Kavali	75	64	4	Daltonganj	72	53
13	Khammam	73	52	5	Darbhanga	64	65
14	Kurnool	67	42	6	Dehri	69	58
15	Mahbubnagar	66	50	7	Dumka	68	60
16	Masulipatnam	77	68	8	Gaya	71	54
17	Medak	66	49	9	Hazaribagh	69	59
18	Nalgonda	75	51	10	Jamshedpur	72	63
19	Nandigama	77	54	11	Jamshedpur (A)	70	56
20	Nandyal	71	50	12	Motihari	77	-
21	Narsapur	82	70	13	Muzaffarpur	73	71
22	Nellore	76	62	14	Patna(A)	74	60
23	Nidadavolu	84	68	15	Purnea	80	71
24	Nizamabad	67	47	16	Ranchi(A)	66	55
25	Ongole	75	60	17	Sabour	77	63
26	Ramgundam	71	52	CHHATTISGARH			
27	Rentachintala	76	55	1	Ambikapur	70	54
				2	Bailaldila	71	-

S. No.	Station	Average Annual Relative Humidity (%)	
		I	II
3	Jagdarpur	74	58
4	Pbo Raipur	67	51
5	Raipur	63	49
6	Raipur(Mana)	61	46
DAMAN & DIU			
1	Diu	66	66
GOA			
1	Dabolim (N.A.S.)	77	69
2	Marmugao	79	74
3	Panjim	82	71
GUJARAT			
1	Ahmedabad	67	41
2	Amreli	69	39
3	Balsar (Valsad)	77	65
4	Baroda (Vadodara)	70	42
5	Baroda (A) (Vadodara)	70	45
6	Bhavnagar (A)	64	44
7	Bhuj (Rudramata)(A)	73	41
8	Deesa	68	39
9	Dohad	70	41
10	Dwarka	80	70
11	Idar	55	36
12	Keshod(A)	69	46
13	Naliya	76	52
14	New Kandla	72	51
15	Okha	76	71
16	Porbandar (A)	72	57
17	Rajkot(A)	71	38
18	Surat	73	53
19	Vallabh Vidyanagar	77	50
20	Veraval	73	72
HARYANA			
1	Ambala	74	52
2	Bhiwani	69	50
3	Gurgaon	68	48
4	Hissar	72	46
5	Karnal	73	55
6	Narnaul	56	46
7	Rohtak	69	50

S. No.	Station	Average Annual Relative Humidity (%)	
		I	II
HIMACHAL PRADESH			
1	Bhuntar(A)	80	48
2	Dharmasala	64	63
3	Kalpa (GL)	59	49
4	Manali	78	64
5	Nahan	70	64
6	Nauni / Solan	68	54
7	Shimla	60	65
8	Sundernagar	83	54
9	Una	77	59
JAMMU & KASHMIR			
1	Badarwah	73	58
2	Banihal	72	52
3	Batote	67	60
4	Gulmarg	73	67
5	Jammu	71	56
6	Kathua	75	-
7	Katra	66	61
8	Kukernag	72	65
9	Kupwara	85	64
10	Pehalgam	83	66
11	Quazigund	79	59
12	Srinagar	79	56
KARNATAKA			
1	Agumbe	89	82
2	Bagalkote	74	60
3	Balehonnur	85	-
4	Bangalore /Bangaluru	80	52
5	Bangalore /Bangaluru (A)	81	52
6	Belgaum (Belgari)	75	-
7	Belgaum Samra(A) (Belgari)	74	53
8	Bellary	65	47
9	Bidar	67	52
10	Bijapur (Vijay pur)	71	47
11	Chickmagalur	74	62
12	Chitradurga	74	49
13	Gadag	73	45
14	Gulbarga	62	41
15	Hassan	82	63
16	Honavar	81	72

S. No.	Station	Average Annual Relative Humidity (%)	
		I	II
17	Karwar	80	72
18	Kolar Gold Field	75	54
19	Mandya	81	57
20	Mangaluru (Panambur)	84	73
21	Mangaluru / Bajpe (A)	82	70
22	Mercara	88	76
23	Mysore	82	61
24	Raichur	59	42
25	Shimoga	81	58
26	Shirali	81	75
27	Tumkur	71	48
KERALA			
1	Alleppy	86	78
2	Kozhicode	83	75
3	Cannanore	79	73
4	Cochin (N. A. S.)	83	73
5	Karipur (Airport)	80	71
6	Kottayam	84	72
7	Palakkad (Palghat)	81	61
8	Punalur	87	66
9	Thiruvananthapuram (Trivandrum)	83	73
LAKSHADWEEP			
1	Agatti(A)	77	73
2	Amini Divi	82	75
3	Minicoy	82	75
MADHYA PRADESH			
1	Alirajpur (Jhabua)	56	50
2	Bagratawa	61	46
3	Betul	70	50
4	Bhopal (Bairagarh)	60	43
5	Chhindwara	70	52
6	Damoh	62	-
7	Datia	65	52
8	Dhar	70	60
9	Ginabahar	66	55
10	Guna	62	43
11	Gwalior	63	46
12	Hoshangabad	65	47
13	Indore	60	40
14	Jabalpur	65	48
15	Jashpurnagar	66	58

S. No.	Station	Average Annual Relative Humidity (%)	
		I	II
16	Kannod	67	50
17	Khajuraho	65	45
18	Khandwa	59	37
19	Khargone	68	62
20	Malanjhand	69	54
21	Mandla	69	54
22	Narsinghpur	67	46
23	Nimach	60	43
24	Nowgong	68	51
25	Panna	61	52
26	Pendra Road	64	53
27	Raigarh	67	52
28	Raisen	-	-
29	Rajgarh	62	43
30	Rajnandgaon	68	53
31	Ratlam	63	41
32	Rewa	61	54
33	Sagar	59	45
34	Satna	65	47
35	Seoni	63	55
36	Shajapur	61	43
37	Sheopur	69	47
38	Shivpuri	61	47
39	Sidhi	66	47
40	Thikri	65	-
41	Tikamgarh	65	60
42	Ujjain	69	42
43	Umaria	70	54
44	Vidisha	73	50
MAHARASHTRA			
1	Ahmednagar	65	48
2	Akola	61	42
3	Akola(A)	60	41
4	Alibag	80	71
5	Amravati	64	51
6	Aurangabad (Chikalthana)(A)	64	45
7	Baramati	61	39
8	Bhira	84	63
9	Bir (Beed)	69	45
10	Brahmapuri	68	49
11	Buldhana	63	44

S. No.	Station	Average Annual Relative Humidity (%)	
		I	II
12	Chandrapur (Chanda)	67	48
13	Dahanu	73	70
14	Devgad (Devgarh)	78	73
15	Gondia	66	50
16	Harnai	71	75
17	Jalgaon	68	43
18	Jeur	68	46
19	Kolhapur	78	55
20	Mahabaleshwar	69	69
21	Malegaon	64	40
22	Miraj (Sangali)	78	51
23	Mumbai(Colaba)	81	71
24	Mumbai(Bombay) (Santa Cruz)	74	63
25	Nagpur (Mayo-Hospital)	-	-
26	Nagpur (Sonegaon)	62	47
27	Nanded	66	43
28	Osmanabad	68	54
29	Ozar(A)	67	44
30	Parbhani	62	44
31	Pune	74	47
32	Pusad	63	46
33	Ratnagiri(PBO)	74	69
34	Satara	73	51
35	Solapur	67	38
36	Sironcha	71	52
37	Vengurla	82	68
38	Wardha	61	47
39	Yeotmal	56	44
MANIPUR			
1	Imphal/ Tulihal(A)	78	70
MEGHALAYA			
1	Barapani	78	-
2	Cherrapunji	75	83
3	Shillong (C.S.O.)	70	84
MIZORAM			
1	Aizwal	-	-
NEW DELHI			
1	New Delhi Palam (A)	68	45
2	New Delhi (Safdarjang)	68	46
3	New Delhi C.H.O	70	47

S. No.	Station	Average Annual Relative Humidity (%)	
		I	II
ORRISA			
1	Angul	72	60
2	Balasore	72	71
3	Baripada	77	70
4	Bhawani Patna	65	54
5	Bhubaneshwar (A)	77	67
6	Bolangir	69	58
7	Chandbali	79	72
8	Cuttack	78	65
9	Gopalpur	81	78
10	Jharsuguda	67	51
11	Keonjhar	70	61
12	Paradip Port	81	79
13	Pulbani	77	66
14	Puri	80	78
15	Sambalpur	72	58
16	Sundergarh	70	62
17	Titlagarh	65	60
PONDICHERY			
1	Puducherry	77	76
2	Puducherry (M.O)	81	75
PUNJAB			
1	Amritsar (Rajasansi)	77	52
2	Kapurthala	79	70
3	Ludhiana	73	51
4	Ludhiana P.A.U.	76	54
5	Patiala	78	57
6	Patiala (Rs/Rw)	78	58
RAJASTHAN			
1	Abu	66	53
2	Ajmer	55	34
3	Banswara	62	43
4	Bharatpur	68	49
5	Barmer	59	32
6	Bhilwara	65	-
7	Bikaner(P.B.O)	56	30
8	Chambal /(RawatBhatta Dam)	61	41
9	Chittorgarh	66	42
10	Churu	62	34
11	Dholpur	57	50

S. No.	Station	Average Annual Relative Humidity (%)	
		I	II
12	Ganganagar	70	43
13	Jaipur (Sanganer)	58	36
14	Jaisalmer	60	31
15	JawaiBandh/Erinpura	66	45
16	Jhalawar	66	43
17	Kota (A)	53	35
18	Kota (PB-Micromet)	55	37
19	Phalodi	59	33
20	Pilani	66	42
21	Sawai Madhopur	63	42
22	Sikar	57	43
23	Udaipur	65	-
24	Udaipur (Dabok)(A)	62	39
SIKKIM			
1	Gangtok	86	83
2	Tadong	81	73
TAMILNADU			
1	Adiramapatinam	77	73
2	Ariyalur	73	61
3	Chennai (Minambakkam) (A)	74	65
4	Chennai (Nungambakkam)	76	69
5	Coimbatore (Pilamedu)	80	54
6	Coonoor	69	-
7	Cuddalore	78	71
8	Dharmapuri	71	52
9	Erode	67	56
10	K. Paramathy	78	54
11	Kanniyakumari	75	74
12	Kodaikanal	73	81
13	Karaikal	79	73
14	Koradacherry	81	65
15	Kudumiamalai	73	49
16	Madurai	74	-
17	Madurai (A)	69	50
18	Mettur Dam	69	45
19	Nagapattinam	78	71
20	Octacamund	77	75
21	Palayamkottai	74	60
22	Pamban	76	73
23	Port Novo	82	72
24	Salem	75	52

S. No.	Station	Average Annual Relative Humidity (%)	
		I	II
25	Tanjavur	80	58
26	Tiruchirapalli (A)	73	50
27	Tiruchi	85	-
28	Tiruppattur	77	62
29	Tiruttani	72	57
30	Tondi	76	76
31	Tuticorin	77	73
32	Vedaranniyam	80	74
33	Vellore	78	55
TRIPURA			
1	Agartala(A)	79	75
2	Kailashahar(A)	83	75
UTTARAKHAND			
1	Dehra Dun	73	61
2	Mukteswar (Kumaun)	62	69
3	Pantnagar	76	60
4	Roorkee	74	56
UTTAR PRADESH			
1	Agra	70	51
2	Aligarh	71	55
3	Allahabad	68	53
4	Bahraich	74	59
5	Ballia	77	66
6	Banda	66	54
7	Barabanki	73	59
8	Bareilly P.B.O.	76	56
9	Churk	67	59
10	Etawah	73	59
11	Faizabad	74	-
12	Fatehgarh	70	60
13	Fatehpur	69	63
14	Gazipur	71	61
15	Gonda	-	-
16	Gorakhpur(P.B.O)	76	61
17	Hamirpur	69	55
18	Hardoi	73	57
19	Jhansi	62	45
20	Kanpur (A)	73	54
21	Kheri- Lakhimpur	78	58
22	Lucknow (Amausi)	72	55
23	Mainpuri	76	59

S. No.	Station	Average Annual Relative Humidity (%)	
		I	II
24	Mathura	65	58
25	Meerut	76	-
26	Moradabad	79	65
27	Mukhim	64	59
28	Muzaffarnagar	74	53
29	Najibabad	76	55
30	Shahajahanpur	75	59
31	Sultanpur (M.O.)	78	64
32	Varanasi	72	57
33	Varanasi (Babatpur)	71	55
WEST BENGAL			
1	Bagati	82	71
2	Balurghat	78	74
3	Bankura	69	68
4	Bankura (M.O.)	78	68
5	Berhampore	79	70
6	Kolkata (Alipur)	77	69
7	Kolkata (Dum Dum) (A)	75	68
8	Canning	79	73
9	Contai	79	77

S. No.	Station	Average Annual Relative Humidity (%)	
		I	II
10	Cooch Behar (A)	80	72
11	Darjeeling	85	84
12	Digha	79	76
13	Diamond Harbour	82	76
14	Haldia	78	73
15	Jalpaiguri	83	78
16	Kalimpong	88	89
17	Krishnanagar	72	66
18	Malda	72	64
19	Midnapore	70	66
20	Purulia	71	59
21	Sagar Island	80	78
22	Sandheads	79	77
23	Shanti-Niketan	76	65
24	Ulberia	86	74

Notes:

I – corresponds to observation at 0830 IST

II – corresponds to observation at 1730 IST

CONCRETE SHELL ELEMENTS

B1.1 This section applies to shell elements, in which there are generally eight components of internal forces. The eight components of internal forces are listed below and shown in Figure B1.1.1 for an element of unit dimensions:

- 3 plate components η_{Edx}, η_{Edy} and $\eta_{Edxy} = \eta_{Edyx}$
- 3 slab components m_{Edx}, m_{Edy} and $m_{Edxy} = m_{Edyx}$
- 2 transverse shear forces v_{Edx}, v_{Edy} .

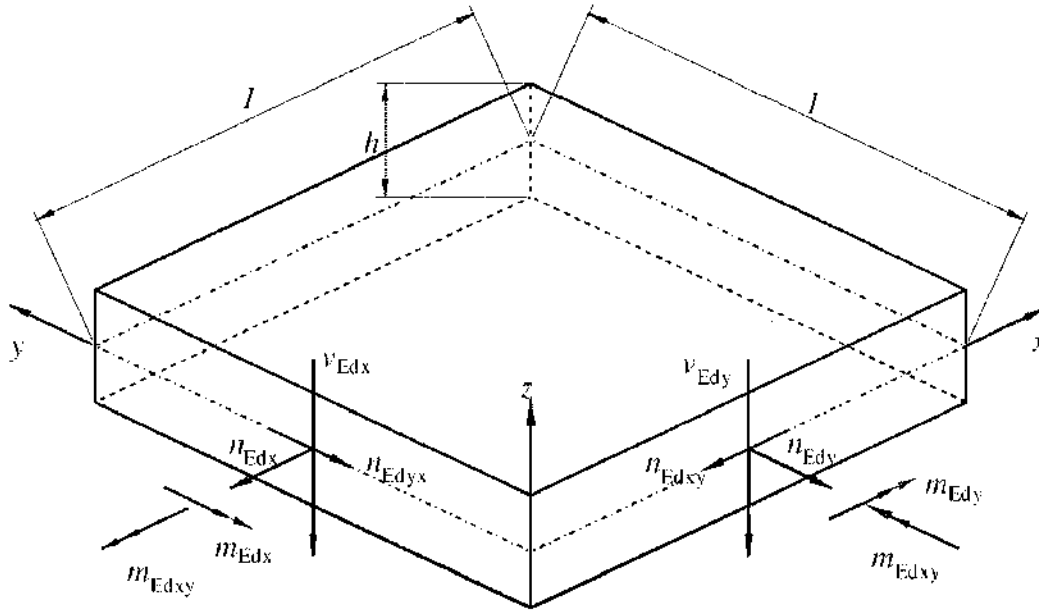

Fig. B1-1 Shell Element

B1.2 The first stage in the verification procedure is to establish if the shell element is uncracked or cracked.

B1.3 In uncracked elements the only verification required is to check that the minimum principle stress is smaller than the design compressive strength f_{cd} . It may be appropriate to take into account the multiaxial compression state in the definition of f_{cd} .

B1.4 In cracked elements a sandwich model should be used for design or verification of the shell element.

B1.5 In the sandwich model three layers are identified (**Fig. B1.2**): The two outer layers resist the membrane actions arising from $\eta_{Edx}, \eta_{Edy}, \eta_{Edxy}, m_{Edx}, m_{Edy}, m_{Edxy}$ and the inner layer carries the shear forces v_{Edx}, v_{Edy} . The thickness of the different layers should be established by means of an iterative procedure (B1.13 and B1.15) (**Fig. B1.2**).

B1.6 The inner layer should be designed according to 10.3 taking into account the principal shear, its principal direction and the longitudinal reinforcement components in that direction (B1.13 to B1.15).

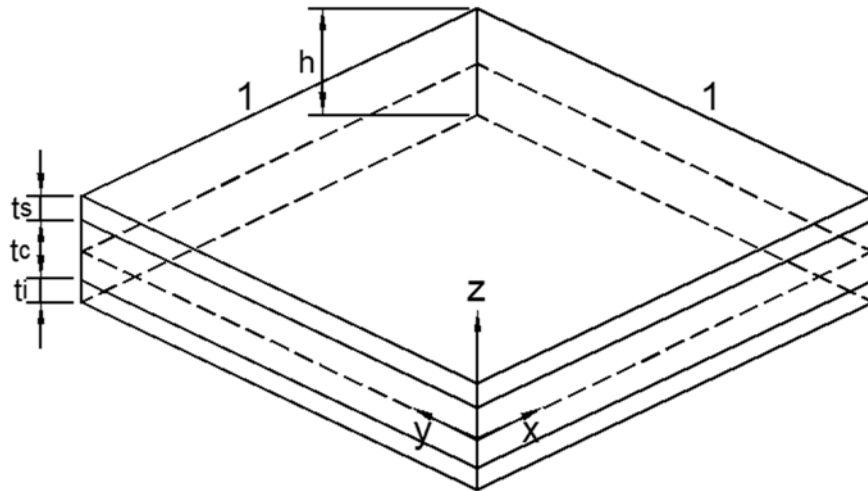

Fig. B1-2 The Sandwich Model

B1.7 In order to establish whether shell elements are cracked, the principal stresses at different levels within the thickness of the element should be checked. In practice the following inequality shall be verified.

$$\phi = \alpha \frac{J_2}{f_{cm}^2} + \lambda \frac{\sqrt{J_2}}{f_{cm}} + \beta \frac{I_1}{f_{cm}} - 1 \leq 0 \tag{Eq. B1-1}$$

where:

$$J_2 = \frac{1}{6} [(\sigma_1 - \sigma_2)^2 + (\sigma_2 - \sigma_3)^2 + (\sigma_3 - \sigma_1)^2] \tag{Eq. B1-2}$$

$$J_3 = (\sigma_1 - \sigma_m)(\sigma_2 - \sigma_m)(\sigma_3 - \sigma_m) \tag{Eq. B1-3}$$

$$I_1 = \sigma_1 + \sigma_2 + \sigma_3 \tag{Eq. B1-4}$$

$$\sigma_m = (\sigma_1 + \sigma_2 + \sigma_3) / 3 \tag{Eq. B1-5}$$

$$\alpha = \frac{1}{9k^{1.4}} \tag{Eq. B1-6}$$

$$\lambda = c_1 \cos \left[\frac{1}{3} \arccos(C_2 \cos 3\theta) \right] \quad \text{for } \cos 3\theta \geq 0 \tag{Eq. B1-7}$$

$$\lambda = c_1 \cos \left[\frac{\pi}{3} - \frac{1}{3} \arccos(-C_2 \cos 3\theta) \right] \quad \text{for } \cos 3\theta < 0$$

$$\beta = \frac{1}{3.7k^{1.1}} \tag{Eq. B1-8}$$

$$\cos 3\theta = 3 \frac{\sqrt{3}}{2} \frac{J_3}{J_2^{3/2}} \tag{Eq. B1-9}$$

$$c_1 = \frac{1}{0.7k^{0.9}} \tag{Eq. B1-10}$$

$$c_2 = 1 - 6.8(k - 0.07)^2 \quad \text{Eq. B1-11}$$

$$K = \frac{f_{ctm}}{f_{cm}} \quad \text{Eq. B1-12}$$

If inequality in Eq. B1-1 is satisfied, then the element is considered to be uncracked; otherwise it should be considered as cracked.

B1.8 If the shell element is considered to be cracked, the forces within the outer layers of the sandwich model shall be determined according to the following equations (**Fig. B1-3** and **B1-4**)

$$n_{Edxs} = n_{Edx} \frac{z_x - y_{xs}}{z_x} + \frac{m_{Edx}}{z_x} \quad \text{Eq. B1-13}$$

$$n_{Edxi} = n_{Edx} \frac{z_x - y_{xi}}{z_x} - \frac{m_{Edx}}{z_x} \quad \text{Eq. B1-14}$$

$$n_{Edys} = n_{Edy} \frac{z_y - y_{ys}}{z_y} + \frac{m_{Edy}}{z_y} \quad \text{Eq. B1-15}$$

$$n_{Edyi} = n_{Edy} \frac{z_y - y_{yi}}{z_y} - \frac{m_{Edy}}{z_y} \quad \text{Eq. B1-16}$$

$$n_{Edyxs} = n_{Edyx} \frac{z_{yx} - y_{yxs}}{z_{yx}} - \frac{m_{Edyx}}{z_{yx}} \quad \text{Eq. B1-17}$$

$$n_{Edyxi} = n_{Edyx} \frac{z_{yx} - y_{yxi}}{z_{yx}} + \frac{m_{Edyx}}{z_{yx}} \quad \text{Eq. B1-18}$$

$$n_{Edxys} = n_{Edxy} \frac{z_{xy} - y_{xys}}{z_{xy}} - \frac{m_{Edxy}}{z_{xy}} \quad \text{Eq. B1-19}$$

$$n_{Edxyi} = n_{Edxy} \frac{z_{xy} - y_{xyi}}{z_{xy}} + \frac{m_{Edxy}}{z_{xy}} \quad \text{Eq. B1-20}$$

Where

z_x and z_y are the lever arms for bending moments and membrane axial forces;

y_{xs} , y_{xi} , y_{ys} , y_{yi} are the distances from the centre of gravity of the reinforcement to mid-plane of the element in the x and y directions, in relation to bending and axial membrane forces; therefore $z_x = y_{xs} + y_{xi}$ and $z_y = y_{ys} + y_{yi}$

y_{yxs} , y_{yxi} , y_{xys} , y_{xyi} are the distances from the centre of gravity of the reinforcement to the mid plane of the element, in relation to torque moment and shear membrane forces; therefore $z_{yx} = y_{yxs} + y_{yxi}$ and $z_{xy} = y_{xys} + y_{xyi}$

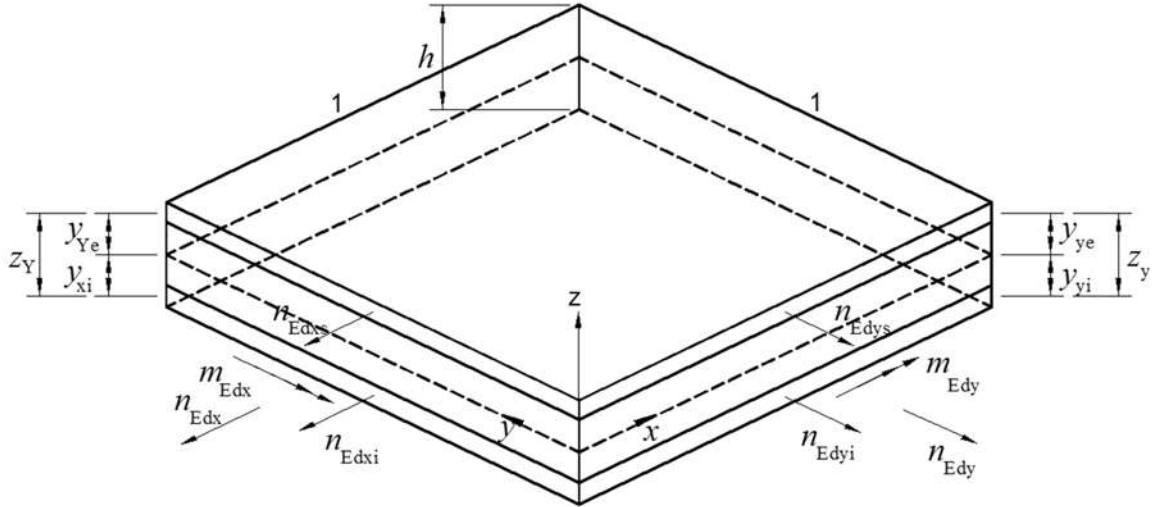

Fig. Anx.B1-3 Axial Actions and Bending Moments in the Outer Layer

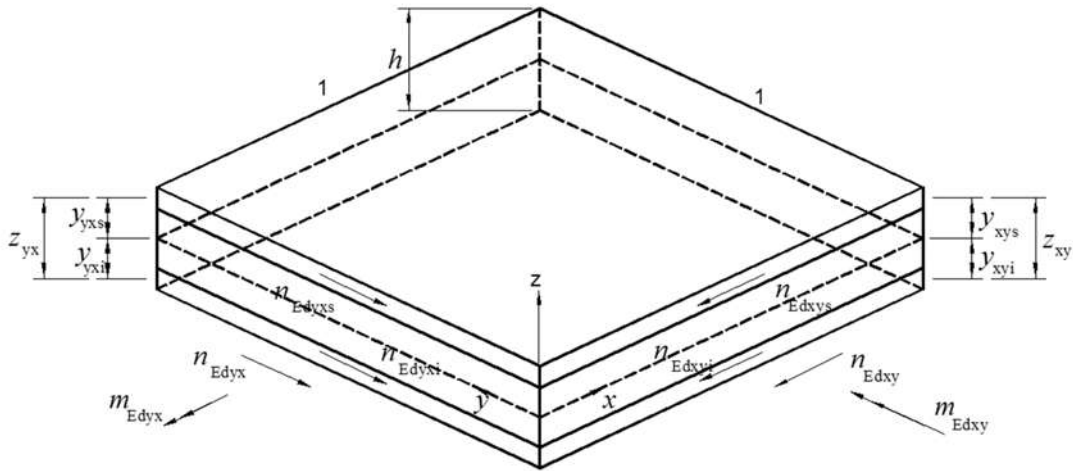

Fig. B1-4 Membrane Shear Actions and Twisting Moments in the Outer Layer

Out of plane shear forces v_{Edx} and v_{Edy} are applied to the inner layer with the layer arm z_c , determined with reference to the centroid of the appropriate layers of reinforcement.

B1.9 For the design of the inner layer the principal shear v_{Edo} and its direction φ_o shall be evaluated as follows:

$$v_{Edo} = \sqrt{v_{Edx}^2 + v_{Edy}^2} \tag{Eq. B1-21}$$

$$\tan \varphi_o = \frac{v_{Edy}}{v_{Edx}} \tag{Eq. B1-22}$$

B1.10 In the direction of principal shear the shell element behaves like a beam and the appropriate design rules should therefore be applied. In particular Clause 10.3.2 should be applied for members not requiring shear reinforcement and Clause 10.3.3 should be applied for members requiring shear

reinforcement. In Expression 10.3.2 ρ_l should be taken as:

$$\rho_l = \rho_x \cos^2 \varphi_o + \rho_y \sin^2 \varphi_o \quad \text{Eq. B1-23}$$

B1.11 When shear reinforcement is necessary, the longitudinal force resulting from the truss model $v_{Edo} \cot \theta$ gives rise to the following membrane forces in x and y directions:

$$n_{Edyc} = \frac{v_{Edy}^2}{v_{Edo}} \cot \theta \quad \text{Eq. B1-24}$$

$$n_{Edxyc} = \frac{v_{Edx} v_{Edy}}{v_{Edo}} \cot \theta \quad \text{Eq. B1-25}$$

$$n_{Edxc} = \frac{v_{Edx}^2}{v_{Edo}} \cot \theta \quad \text{Eq. B1-26}$$

$$n_{Edyxc} = n_{Edxyc} = \frac{v_{Edx} v_{Edy}}{v_{Edo}} \cot \theta \quad \text{Eq. B1-27}$$

B1.12 The outer layers shall be designed as membrane elements, using design rules of section 9.

B1.13 The following simplified approach may generally be adopted with respect to **Fig.B1-3** and **Fig.B1-4**.

$$y_{ns} = y_{xs} = y_{ys} \quad \text{Eq. B1-28}$$

$$y_{ni} = y_{xi} = y_{yi} \quad \text{Eq. B1-29}$$

$$y_{ts} = y_{xys} = y_{yxs} \quad \text{Eq. B1-30}$$

$$y_{ti} = y_{xyi} = y_{yxi} \quad \text{Eq. B1-31}$$

$$z_x = z_y = z_n = y_{ns} + y_{ni} \quad \text{Eq. B1-32}$$

$$z_{xy} = z_{yx} = z_t = y_{ts} + y_{ti} \quad \text{Eq. B1-33}$$

The difference between z_n and z_t may generally be ignored, assuming the thickness of the outer layers to be twice the effective concrete cover, therefore:

$$y_{ns} = y_{ts} = y_s \quad \text{Eq. B1-34}$$

$$y_{ni} = y_{ti} = y_i \quad \text{Eq. B1-35}$$

$$z_n = z_t = z \quad \text{Eq. B1-36}$$

B1.14 Based on the above assumptions, the forces in the outer layers can be evaluated as follows:

- (a) In the case for which no shear reinforcement is required to resist v_{Edx} and v_{Edy}

$$n_{Edxs} = n_{Edx} \frac{z - y_s}{z} + \frac{m_{Edx}}{z} \quad \text{Eq. B1-37}$$

$$n_{Edxi} = n_{Edx} \frac{z - y_i}{z} - \frac{m_{Edx}}{z} \quad \text{Eq. B1-38}$$

$$n_{Edys} = n_{Edy} \frac{z - y_s}{z} + \frac{m_{Edy}}{z} \quad \text{Eq. B1-39}$$

$$n_{Edyi} = n_{Edy} \frac{z - y_i}{z} - \frac{m_{Edy}}{z} \quad \text{Eq. B1-40}$$

$$n_{Edxys} = n_{Edxy} \frac{z - y_s}{z} - \frac{m_{Edxy}}{z} \quad \text{Eq. B1-41}$$

$$n_{Edxyi} = n_{Edxy} \frac{z - y_i}{z} + \frac{m_{Edxy}}{z} \quad \text{Eq. B1-42}$$

- b) In the case for which shear reinforcement is required to resist v_{Edx} and v_{Edy} .

$$n_{Edxs} = n_{Edx} \frac{z - y_s}{z} + \frac{m_{Edx}}{z} + \frac{1}{2} \frac{v_{Edx}^2}{v_{Edo}} \cot \theta \quad \text{Eq. B1-43}$$

$$n_{Edxi} = n_{Edx} \frac{z - y_i}{z} - \frac{m_{Edx}}{z} + \frac{1}{2} \frac{v_{Edx}^2}{v_{Edo}} \cot \theta \quad \text{Eq. B1-44}$$

$$n_{Edys} = n_{Edy} \frac{z - y_s}{z} + \frac{m_{Edy}}{z} + \frac{1}{2} \frac{v_{Edy}^2}{v_{Edo}} \cot \theta \quad \text{Eq. B1-45}$$

$$n_{Edyi} = n_{Edy} \frac{z - y_i}{z} - \frac{m_{Edy}}{z} + \frac{1}{2} \frac{v_{Edy}^2}{v_{Edo}} \cot \theta \quad \text{Eq. B1-46}$$

$$n_{Edxys} = n_{Edxy} \frac{z - y_s}{z} - \frac{m_{Edxy}}{z} + \frac{1}{2} \frac{v_{Edx} v_{Edy}}{v_{Edo}} \cot \theta \quad \text{Eq. B1-47}$$

$$n_{Edxyi} = n_{Edxy} \frac{z - y_i}{z} + \frac{m_{Edxy}}{z} + \frac{1}{2} \frac{v_{Edx} v_{Edy}}{v_{Edo}} \cot \theta \quad \text{Eq. B1-48}$$

B1.15 If the verification in (B1-12) above is not satisfied, one of the following procedures shall be followed.

- increase the concrete cover and consequently reduce the internal lever arm;
- use different values for z_n and z_t with $z_n > z_t$, internal concrete stresses should then be added vectorially;
- Increase the layer thickness to satisfy the concrete verification and leave the reinforcement position unchanged. This will cause the reinforcement to become eccentric in the layer; as a consequence two internal bending moments arise, and these should be in equilibrium within the shell element. In these circumstances, the forces in internal reinforcement become:

$$n_{Eds}^* = \left[n_{Eds} \left(h - \frac{t_s}{2} - b_i' \right) + n_{Edi} \left(\frac{t_i}{2} - b_i' \right) \right] / (h - b_i' - b_s')$$

Eq. B1- 49

$$n_{Edi}^* = n_{Eds} + n_{Edi} - n_{Eds}^*$$

Eq. B1- 50

Where:

t_s and t_i are the thickness of top and bottom layers, respectively.

b_i' is the distance from the external surface of the layer to the axis of the reinforcement within the layer.

The internal layer should be checked for an additional out of the plane shear corresponding to the force transfer between the layers of reinforcement.

MECHANISMS OF DETERIORATION OF CONCRETE STRUCTURES

This Annexure gives description of the main deterioration mechanisms which may need to be considered in design.

B2.1 Corrosion of Reinforcement/Prestressing Tendons

In normal circumstances, the highly alkaline nature of concrete protects steel embedded within it. The pH value of the pore solution in concrete is generally in the region of 12 to 14. The protection is afforded by the formation of a very thin, coherent layer of iron oxide over the surface of the steel bar under such alkaline conditions. Steel protected in this way is described as being in a passive state. Steel will not generally corrode in uncontaminated concrete until the pH drops below 10. Two mechanisms, which can lead to the destruction of this passive state, are:-

(1) Carbonation of Concrete

This is a reaction between carbon dioxide in the atmosphere and the calcium hydroxide in the hydrated cement matrix. This process starts at the surface and with time, penetrates slowly into the concrete. The rate of penetration of carbonation into the concrete, is the highest, where the relative humidity is in the range 50 to 70 percent. It is lower at higher humidities, being effectively zero at 100 percent. The rate is also lower at lower humidities, being effectively zero at (zero) percent humidity, because carbonation can not take place without presence of water. The rate of carbonation will be lower in good quality concrete as compared to that in poor quality concrete. The rate of carbonation depends on the rate at which carbon dioxide can diffuse into the concrete. This will decrease with a decrease in the water/cement ratio. The effect of carbonation is to reduce the alkalinity of the concrete surrounding the reinforcement to a level where the natural protection is lost.

(2) The presence of Chlorides in Concrete

Chlorides have the capacity to destroy the passivity of steel locally, even where the alkalinity remains high, giving rise to 'pitting corrosion'. Chlorides may get into the concrete from various sources, but the commonest are seawater in marine environments; chloride ions, if any, contained in the ingredients of concrete, particularly the mix water; and de-icing chemicals on bridge decks as used in colder climates. The rate of ingress of chloride into the concrete depends upon the amount of chloride in the service environment in contact with the concrete surface and on the quality of the concrete. Once the passivity of the steel has been destroyed, occurrence of corrosion of steel requires only two things; sufficient moisture and sufficient oxygen. It is found that these two requirements can act against each other since, if the concrete is wet, oxygen cannot penetrate and if it is dry, there is insufficient moisture for the reaction to progress. As a result, the greatest risk of corrosion is in members subjected to alternate wetting and drying.

B2.2 Frost Attack

If saturated concrete is subjected to frequent freezing and thawing, the expansive effects of ice formation will disrupt the concrete. The usual manifestations of frost damage are surface spalling or the formation of closely spaced surface cracks. Concrete, which is not close to being saturated, is not at risk from frost as the expansion that occurs on freezing can be accommodated in the pores not filled with water. Except in a few areas in colder regions of the country, frost attack may not pose a significant problem.

B2.3 Alkali-aggregate Reactions

There are two basic forms of reaction which occasionally occur and can damage concrete: viz. - the alkali-silica reaction and the alkali-carbonate reaction. The alkali-silica reaction is the more common in India. It is a reaction between the alkalis (sodium and potassium salts) in the cement and certain forms of glassy or crypto-crystalline silica in the aggregate, which results in the formation of a hygroscopic 'silica gel'. This gel expands when in contact with water, resulting in the formation of cracks, which may be large (several millimeters wide are not uncommon). In relatively unstressed and unreinforced concrete, these cracks can form a random 'map' pattern. In other cases, the cracks will tend to form parallel to the direction of compressive stress or reinforcement. The cracks are usually not deep, only extending 50-70 mm into the section. Their effect on structural performance is not as great as might be imagined from looking at the cracks. A reduction in the compressive and tensile strengths and modulus of elasticity of the concrete occurs, but this is commonly not more than about 20-30 percent.

In India, siliceous rocks like granite, granite gneiss and schist, quartzite and sandstone, containing 'strained quartz' have been found to be reactive. The methods of evaluation are given in IS 2386; more refined methods of detection of reactivity of aggregates are being evolved, for which, specialist literature may be consulted.

B2.4 Attack from Sulphates

In the presence of water, sulphate ions can react with the tricalcium aluminate component of the cement. This reaction causes expansion, leading to cracking and eventual disintegration of the concrete. The commonest source of sulphates is in the earth surrounding foundations but other sources are sometimes significant. Seawater contains significant amounts of sulphates in addition to chlorides. The severity of attack depends on the concentration of sulphate ions in the soil and subsoil water and in the environment.

B2.5 Attack by Aggressive Chemicals

Effluents, vapours, fumes etc. from chemical and fertilizer industries can attack concrete, leading to its disintegration. In case of a bridge structure being exposed to such harmful chemicals due to proximity to such industries, the structure should be designed for 'extreme' exposure condition (**Table 14.1**). Protective coatings may be required. For further guidance, specialist literature may be referred.

B2.6 Acid Attack

No concrete is acid resistant. Even mild acids can attack the calcium compounds in concrete, converting them to soluble salts, which can then leach away. The effect of acids is therefore to eat away, or render the surface of the concrete weak and permeable. Acid rain, for example, will do no more than etch the surface of the concrete over any reasonable design life. If the concrete is likely to be exposed to major amounts of acid, for example from some industrial process, the only way to avoid damage is to provide an impermeable coating to the concrete.

B2.7 Abrasion

Abrasion of concrete surfaces may occur due to movement of boulders, sand or gravel suspended in turbulent water, or air borne sand particles. Resistance to abrasion can be obtained by using higher strength concrete and abrasion resistant aggregates. Resistance is also markedly improved by good curing of surfaces likely to be exposed to abrasive action.

EFFECT OF LIVE LOADS ON DECK SLABS

B3.1 Scope

The effect of concentrated loads on slabs spanning in one or two directions or on cantilever slabs may be calculated from the influence fields of such loads or by any other rational method. A value of 0.2 may be assumed for Poisson's ratio. A simplified method for estimating the action of concentrated loads on slab, based on effective width method for cantilever and simply supported slab, is described below, which may be used where more detailed calculations are not performed.

B3.2 Effective Width

The bending moment per unit width of slab caused by concentrated loads on solid slabs spanning in one direction or on cantilever slabs, may also be calculated by assessing the width of slab that may be taken as effective in resisting the bending moment due to the concentrated loads. For precast slabs, the term 'actual width of slab' used in this Clause shall indicate the actual width of each individual precast unit.

Slabs designed on the above basis need not be checked for shear.

(1) Solid slab spanning in one direction

- (i) For a single concentrated load, the effective width may be calculated in accordance with the following equation:

$$b_{ef} = \alpha \cdot a \cdot \left(1 - \frac{a}{l_o} \right) + b_1 \quad \text{Eq. B3.1}$$

where

b_{ef} = the effective width of slab on which the load acts,

l_o = the effective span,

a = the distance of the centre of gravity of the concentrated load from the nearer support,

b_1 = the breadth of concentration area of the load, i.e., the dimension of the tyre or track contact area over the road surface of the slab in a direction at right angles to the span plus twice the thickness of the wearing coat or surface finish above the structural slab, and

α = a constant having the following values depending upon the ratio b/l_o where b is the width of the slab.

Provided that the effective width shall not exceed the actual width of the slab; and provided further that in case of a load near the unsupported edge of a slab, the effective width shall not exceed the above value nor half the above value plus the distance of the load from the unsupported edge.

b/l_o	α for simply supported slab	α for continuous slab	b/l_o	α for simply supported slab	α for continuous slab
0.1	0.40	0.40	1.1	2.60	2.28
0.2	0.80	0.80	1.2	2.64	2.36
0.3	1.16	1.16	1.3	2.72	2.40
0.4	1.48	1.44	1.4	2.80	2.48
0.5	1.72	1.68	1.5	2.84	2.48
0.6	1.96	1.84	1.6	2.88	2.52
0.7	2.12	1.96	1.7	2.92	2.56
0.8	2.24	2.08	1.8	2.96	2.60
0.9	2.36	2.16	1.9	3.00	2.60
1.0	2.48	2.24	2 & above	3.00	2.60

- (ii) For two or more concentrated loads in a line in the direction of the span, the bending moment per unit width of slab shall be calculated separately for each load according to its appropriate effective width of slab calculated as in (i) above.
- (iii) For two or more loads not in a line in the direction of the span: If the effective width of slab for one load overlaps the effective width of slab for an adjacent load, the resultant effective width for the two loads equals the sum of the respective effective widths for each load minus the width of overlap, provided that the slab so designed is tested for the two loads acting separately.

(2) **Solid slab cantilever**

- (i) For a single concentrated load, the effective width may be calculated in accordance with the following equation:

$$b_{ef} = 1.2a + b_1 \quad \text{Eq. B3.2}$$

where

b_{ef} = the effective width,

a = the distance of the centre of gravity of the concentrated load from the face of the cantilever support, and

b_1 = the breadth of concentration area of load, i.e., the dimension of the tyre or track contact area over the road surface of the slab in a direction parallel to the supporting edge of the cantilever plus twice the thickness of wearing coat or surface finish above the structural slab.

Provided that the effective width of the cantilever slab shall not exceed one-third the length of the cantilever slab measured parallel to the support. And provided further that when the concentrated load is placed near one of the two extreme ends of the length of cantilever slab in the direction parallel to the support, the effective width shall not exceed the above value, nor shall it exceed half the above value plus the distance of the concentrated load from the nearer extreme end measured in the direction parallel to the fixed edge.

- (ii) For two or more concentrated loads

If the effective width of slab for one load overlaps the effective width of slab for an adjacent load, resultant effective width for the two loads shall be taken as equal to the sum of the respective effective width for each load minus the width of overlap, provided that the slab so designed is tested for the two loads acting separately.

B3.3 Dispersion of Loads along the Span

The effect of contact of wheel or track load in the direction of span length shall be taken as equal to the dimension of the tyre contact area over the wearing surface of the slab in the direction of the span plus twice the overall depth of the slab inclusive of the thickness of the wearing surface.

B3.4 Dispersion of Loads through Fills and Wearing Coat

The dispersion of loads through fills and wearing coat shall be assumed at 45°, both along and perpendicular to the span.

(The Official amendments to this document would be published by the IRC in its periodical, 'Indian Highways' which shall be considered as effective and as part of the Code/Guidelines/Manual, etc. from the date specified therein)

ISBN 978-93-86512-68-0



9 789386 512680