

**HANDBOOK
ON
CONCRETE
REINFORCEMENT
AND
DETAILING**

BUREAU OF INDIAN STANDARDS

FOREWORD

Users of various civil engineering codes have been feeling the need for explanatory handbooks and other compilations based on Indian Standards. The need has been further emphasized in view of the publication of the National Building Code of India in 1970 and its implementation. The Expert Group set up in 1972 by the Department of Science and Technology, Government of India carried out in-depth studies in various areas of civil engineering and construction practices. During the preparation of the Fifth Five-Year Plan in 1975, the Group was assigned the task of producing a Science and Technology plan for research, development and extension work in the sector of housing and construction technology. One of the items of this plan was the production of design handbooks, explanatory handbooks and design aids based on the National Building Code and various Indian Standards and other activities in the promotion of the National Building Code. The Expert Group gave high priority to this item and on the recommendation of the Department of Science and Technology, the Planning Commission approved the following two projects which were assigned to the Bureau of Indian Standards :

- a) Development programme on code implementation for building and civil engineering construction, and
- b) Typification for industrial buildings.

A Special Committee for Implementation of Science and Technology Projects (SCIP) consisting of experts connected with different aspects was set up in 1974 to advise the BIS Directorate General in identification and for guiding the development of the work. Under the first programme, the Committee has so far identified subjects for several explanatory handbooks/compilations covering appropriate Indian Standards codes specifications which include the following :

Design Aids for Reinforced Concrete to IS : 456-1978 (SP : 16-1980)

Explanatory Handbook on Masonry Code (SP : 20-1981)

Explanatory Handbook
on Codes of Earthquake Engineering (IS : 1893-1975 and
IS : 4326-1976) (SP : 22-1982)

Handbook on Concrete Mixes (SP : 23-1982)

Explanatory Handbook on Indian Standard Code of Practice for Plain and Reinforced
Concrete (IS : 456-1978) (SP : 24-1983)

Handbook on Causes and Prevention of Cracks in Buildings (SP : 25-1984)

Summaries of Indian Standards for Building Materials (SP : 21-1983)

Functional Requirements of Industrial Buildings (Lighting and Ventilation)
(SP : 32-1986)

Timber Engineering (SP : 33-1986)

Water Supply and Drainage with Special Emphasis on Plumbing (SP : 35-1987)

Functional Requirements of Buildings*

Foundation of Buildings

Steel Code (IS : 800-1984)

Building Construction Practices

Bulk Storage Structures in Steel

Formwork

Fire Safety

Construction Safety Practices

Tall Buildings

Loading Code

This Handbook provides information on properties of reinforcing steel and detailing requirements, including storage, fabrication, assembly, welding and placing of reinforcement in accordance with IS : 456-1978. As a result of the introduction of limit state method of design for reinforced concrete structures and the concept of development length, detailing has become extremely important as many of the design requirements are to be met through detailing. This Handbook is expected to guide the designer in detailing which include correct positioning of bars for a particular type of structural element and preparation of bar bending schedule. The detailing requirements as specified in IS : 456-1978 have been brought out as applicable to different structural elements in a building and explained, wherever necessary. The relevant Indian Standards and other literature available on the subject have been taken into consideration in preparing the Handbook. The Handbook will be useful to concrete design engineers, field engineers and students of civil engineering.

Some of the important points to be kept in view in the use of the Handbook are :

- a) The reinforcement has to cater to forces (bending moment, shear force, direct compression or direct tension) at sections consistent with development length requirements at the particular section. Sound engineering judgement shall be exercised while applying the provisions herein and detailing should be such that the structural element satisfies the requirements of performance for which it is meant. Typical detailing drawings are included to illustrate one possible method of arrangement of bars for a particular condition. They should not be construed as the only possible method.
- b) Considering the importance of ductility requirements in structures subjected to severe earthquakes, a separate section is included on the detailing requirements for buildings in severe earthquake zones (Zones IV and V of IS : 1893-1984).
- c) International Standard ISO 4066-1977 'Buildings and civil engineering drawings—Bar scheduling' is reproduced in Appendix B as a supplement to what is contained in the Handbook.
- d) *The Handbook does not form part of any Indian Standard on the subject and does not have the status of an Indian Standard. In case of dispute about interpretation or opinion expressed in the Handbook, the provisions of relevant Indian Standards only shall apply. The provisions of the Handbook particularly those relating to other literature should be considered as only supplementary information*
- e) The Handbook is expected to serve as a companion document to the three handbooks already published on the subject of reinforced concrete, namely, SP : 16-1980, SP : 23-1982 and SP : 24-1983.
- f) All dimensions are in mm unless otherwise specified.

The Handbook is based on the first draft prepared by the Central Public Works Department, New Delhi. Shri B. R. Narayanappa, Deputy Director, and Shri P. S. Chadha, Officer on Special Duty, Bureau of Indian Standards (BIS), were associated with the work. The assistance rendered by Shri A. C. Gupta, Assistant Chief Design Engineer, National Thermal Power Corporation (NTPC), New Delhi, in the preparation of this Handbook specially in the formulation of drawings is acknowledged.

The draft Handbook was circulated for review to National Council for Cement and Building Materials, New Delhi; Structural Engineering Research Centre, Madras; Indian Institute of Technology, Madras; Indian Institute of Technology, New Delhi; Andhra Pradesh Engineering Research Laboratories, Hyderabad; Engineering Construction Corporation Ltd, Madras; Engineer-in-Chief's Branch, Army Headquarters, New Delhi; Engineering Consultants (India) Limited, New Delhi; Gammon India Ltd, Bombay; M/s C. R. Narayana Rao, Architects & Engineers, Madras; STUP Consultants Ltd, Bombay; Research, Design and Standards Organization, Ministry of Railways, Lucknow; Irrigation Department, Government of Gujarat; M/s H. K. Sen and Associates, Calcutta; Siddharth Shankar and Associates (Consulting Engineers), New Delhi; Roy and Partners (Architects & Engineers), New Delhi; Shrish Malpani (Architects & Engineers), New Delhi; and the views received were taken into consideration while finalizing the Handbook.

SECTION 1
Steel for Reinforcement

SECTION 1

STEEL FOR REINFORCEMENT

1.0 Reinforcing bars/wires for concrete reinforcement shall be any of the following conforming to accepted standards:

- a) Mild steel and medium tensile steel bars [IS : 432 (Part 1)-1982 Specification for mild steel and medium tensile steel bars and hard-drawn steel wire for concrete reinforcement : Part 1 Mild steel and medium tensile steel bars (*third revision*)].
- b) High strength deformed steel bars/wires [IS : 1786-1985 Specification for high strength deformed steel bars and wires for concrete reinforcement (*third revision*)].
- c) Hard-drawn steel wire fabric [IS : 1566-1982 Specification for hard-drawn steel wire fabric for concrete reinforcement (*second revision*)].

The requirements for manufacture and supply of different types of steel reinforcement are briefly highlighted in 1.1 to 1.3.4.3.

NOTE — Different types of reinforcing bars, such as plain bars and deformed bars of various grades, say Fe415 (N/mm²) and Fe500 (N/mm²), should not be used side by side as this practice will lead to confusion and error at site. However, secondary reinforcement such as ties and stirrups, may be of mild steel throughout even though the main steel may be of high strength deformed bars.

1.1 Mild Steel and Medium Tensile Steel Bars

1.1.1 Reinforcement supplied shall be classified into the following types:

- a) mild steel bars, and
- b) medium tensile steel bars.

1.1.1.1 Mild steel bars shall be supplied in the following two grades:

- a) mild steel bars, Grade I; and
- b) mild steel bars, Grade II.

NOTE — In all cases where the design seismic coefficient [see IS : 1893-1984 Criteria for earthquake resistant design of structures (*fourth revision*)] chosen for the structure is 0.05 or more (which include earthquake zones IV and V) and for structures subjected to dynamic loading, use of Grade II bars is not recommended.

1.1.2 Physical/Mechanical Properties — The requirements for physical/mechanical properties of mild steel and medium tensile steel bars are given in Table 1.1.

1.1.3 Tolerance — The rolling and cutting tolerances shall be as specified in 1.1.3.1 and 1.1.3.2.

1.1.3.1 Bars in straight lengths

a) The tolerance on diameter shall be as follows:

| Diameter | | Tolerance, percent |
|----------|---------------------|--------------------|
| Over | Up to and including | |
| mm | mm | mm |
| — | 25 | ±0.5 |
| 25 | 35 | ±0.6 |
| 35 | 50 | ±0.8 |
| 50 | 80 | ±1.0 |
| 80 | 100 | ±1.3 |
| 100 | — | ±1.6 |

b) The permissible ovality measured as the difference between the maximum and minimum diameter shall be 75 percent of the tolerance (±) specified on diameter.

c) The tolerance on weight per m length shall be as follows:

| Diameter | | Tolerance, percent |
|----------|---------------------|--------------------|
| Over | Up to and including | |
| mm | mm | |
| — | 10 | ±7 |
| 10 | 16 | ±5 |
| 16 | — | ±3 |

1.1.3.2 Coiled bars

a) The tolerance on diameter shall be ±0.5 mm for diameters up to and including 12 mm.

b) The difference between the maximum and minimum diameter at any cross-section shall not exceed 0.65 mm.

NOTE — No weight tolerance is specified for coiled bars.

1.2 High Strength Deformed Steel Bars

1.2.1 Deformed steel bars/wires for use as reinforcement in concrete shall be in the following three grades:

- a) Fe415,
- b) Fe500, and
- c) Fe550.

TABLE 1.1 REQUIREMENTS FOR REINFORCING BARS
(Clauses 1.1.4, 1.2.2, 1.2.5 and 1.3.1)

| IS No. | TYPE OF REINFORCEMENT | NOMINAL SIZE OF BARS | CHARACTERISTIC STRENGTH (Yield Stress or 2 Percent Proof ¹ Stress) | MINIMUM ULTIMATE TENSILE STRESS | COMPOSITION OF STEEL CONFORMING TO IS | MINIMUM ELONGATION ON GAUGE LENGTH OF $5.65\sqrt{\text{AREA}}$ |
|-------------------------------------|-----------------------------------|--|---|--|--|--|
| (1) | (2) | (3) | (4) | (5) | (6) | (7) |
| | | (mm) | (N/mm ²) | (N/mm ²) | | (percent) |
| IS : 432 (Part 1)-1982 ^a | Mild steel (Grade I) | 5,6,8,10,12,16,20 | 250 | 410 | IS : 226-1975† | 23 |
| | | 22,25,28,32,36,40,45,50 | 240 | | | |
| | Mild steel (Grade II) | 5,6,8,10,12,16,20 | 225 | 370 | Fe 410.0 of IS : 1977-1975‡ | 23 |
| | | 22,25,28,32,36,40,45,50 | 215 | | | |
| | Medium tensile steel | 5,6,8,10,12,16 | 350 | 540 | Fe 540 W-HT of IS : 961-1975§ | 20 |
| | | 20,22,25,28,32,36,40,45,50 | 340 | | | |
| | | 36,40,45,50 | 330 | 510 | do | 20 |
| IS : 1786-1985 | High strength deformed bars/wires | 4,5,6,7,8,10,12,16,18,20,22,25,28,32,36,40,45,50 | 415 (for Fe 415) | 10 percent more than the actual 0.2 percent proof stress but not less than 485.0 N/mm ² | C - 0.30 S - 0.06 P - 0.06 S + P - 0.11 | 14.5 |
| | | | 500 (for Fe 500) | 8 percent more than the actual 0.2 percent proof stress but not less than 545.0 N/mm ² | C - 0.3 S - 0.055 P - 0.055 S + P - 0.105 | 12.0 |

| IS No. | TYPE OF REINFORCEMENT | NOMINAL SIZE OF BARS | CHARACTERISTIC STRENGTH (Yield Stress or 2 Percent Proof Stress) | MINIMUM ULTIMATE TENSILE STRESS | COMPOSITION OF STEEL CONFORMING TO IS | MINIMUM ELONGATION ON GAUGE LENGTH OF $5.65\sqrt{\text{AREA}}$ |
|----------------|------------------------------|----------------------|--|---|---|--|
| (1) | (2) | (3) (mm) | (4) (N/mm ²) | (5) (N/mm ²) | (6) | (7) (percent) |
| | | | 550 (for Fe 550) | 6 percent more than the actual 0.2 percent proof stress but not less than 585 N/mm ² | C - 0.3 S - 0.055 P - 0.050 S + P - 0.10 | 8.0 |
| IS : 1566-1981 | Hard-drawn steel wire fabric | (See Note 1) | 480 | 570 | S - 0.05 P - 0.05 | 7.5 (over a gauge length of 8 ϕ) |

NOTE 1 — The mesh sizes and sizes of wire for square as well as oblong welded wire fabric commonly manufactured in the country are given in Appendix C

NOTE 2 — The weight and area of different sizes of bars are given in Appendix C.

NOTE 3 — Generally available ex stock:

Mild steel bars — $\phi 6, \phi 10, \phi 12, \phi 16, \phi 20, \phi 25, \phi 32$

Deformed steel bars — #8, #10, #12, #16, #20, #22, #25, #28, #32

The maximum length of reinforcing bars available ex stock is 13 m.

NOTE 4 — For each bundle/coil of bars/wires, a tag shall be attached indicating cast No./lot No., grade and size by the manufacturer or the supplier.

*Specification for mild steel and medium tensile steel bars and hard-drawn steel wire for concrete reinforcement: Part I Mild steel and medium tensile steel bars (third revision).

†Specification for structural steel (standard quality) (fifth revision).

‡Specification for structural steel (ordinary quality) (second revision).

§Specification for structural steel (high quality) (second revision).

#Specification for high strength deformed steel bars and wires for concrete reinforcement (third revision).

||Specification for hard-drawn steel wire fabric for concrete reinforcement (second revision).

NOTE — The figures following the symbol Fe indicates the specified minimum 0.2 percent proof stress or yield stress in N/mm².

1.2.3 Tolerance

1.2.3.1 Cutting tolerance on length — The cutting tolerances on length shall be as specified below:

- a) When the specified length is +75 mm not stated to be either a maximum or a minimum -25 mm
- b) When the minimum length is +50 mm specified - 0 mm

NOTE — These are tolerances for manufacture and supply and are not applicable for fabrication. For allowable tolerances for bending and cutting during fabrication see Section 13.

1.2.3.2 Mass — For the purpose of checking the nominal mass, the density of steel shall be taken as 0.785 kg/cm² of the cross-sectional area per metre run. Tolerances on nominal mass shall be as follows:

| Nominal Size mm | Tolerance on the Nominal Mass, Percent when Checked in | | |
|--------------------------------|---|--|--|
| | Batch (each Specimen not less than 0.5 m) | Indivi- dual Sample (not less than 0.5 m) | Indivi- dual Sample for Coils* |
| Up to and including 10 | ±7 | -8 | ±8 |
| over 10 up to and including 16 | ±5 | -6 | ±6 |
| Over 16 | ±3 | -4 | ±4 |

1.2.4 Physical/Mechanical Properties — The requirement for physical/mechanical properties of high strength deformed steel bars are given in Table 1.1.

NOTE 1 — the nominal diameter or size of a deformed bar/wire is equivalent diameter or size of a plain round bar/wire having the same mass per metre length as the deformed bar/wire.

NOTE 2 — The effective diameter, ϕ , of a deformed bar/wire is determined as follows, using a bar/wire not less than 0.5 m in length:

$$\phi = \sqrt{\frac{162.13 w}{L}}$$

where

w = mass in kg weighed to a precision of ±0.5 percent, and

L = length in m measured to a precision of ±0.5 percent.

*For coils, batch tolerance is not applicable. At least 2 samples of minimum one metre length shall be taken from each end of the coil.

1.3 Hard-drawn Steel Wire Fabric

1.3.1 General — Hard-drawn steel wire fabric consists of longitudinal and transverse wires (at right angles to one another) joined by resistance spot welding. Fabrication of wire fabric by welding has the quality of factory fabrication and reduces cost of labour and fabrication in the field.

1.3.2 Types — Hard-drawn steel wire fabric shall be made in the following two types:

- a) square mesh, and
- b) oblong mesh.

The diameter of wires in the square mesh varies from 3 to 10 mm; the diameter being same in both longitudinal and transverse directions. In this case both longitudinal and transverse bars may serve as main reinforcement. The diameter of wire in the oblong mesh varies from 5 to 8 mm in the longitudinal direction and 4.2 to 6 mm in the transverse direction. The wires in the direction of larger diameter can serve as main reinforcement and the wires in the cross direction can serve as distribution steel.

1.3.2.1 The maximum width of wire fabric in rolls is 3.5 m; the length of this type of fabric is limited by the weight of rolls which may range from 100 to 500 kg. The maximum width of fabric in the form of sheets is 2.5 m and the maximum length is 9.0 m. The dimension of width is to be taken as centre-to-centre distance between outside longitudinal wires. The width of wires fabric in rolls or sheets shall be such as to fit in with the modular size of 10 cm module and length in suitable intervals (see Fig. (1.1)).

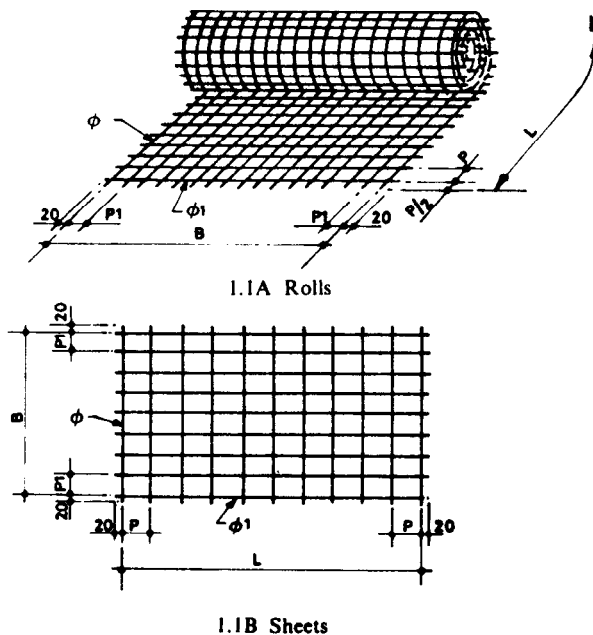

FIG. 1.1 WELDED WIRE FABRIC

1.3.2.2 The fabric may be designated for ordering purposes by the number of the standard and the reference number given as in the first column of Table C-1 of Appendix C, or alternately a complete description of the fabric may be given.

When denoting the size of rolls or sheets of oblong mesh fabric, the first dimension shall be the length of the main wires.

Example : Hard-drawn steel wire fabric according to IS : 1566 corresponding to SI No. 5 : 50 sheets of size 5 m × 2 m

1.3.3 Mass— The nominal mass of fabric shall be calculated on the basis that steel weighs 0.785 kg/cm² of nominal cross-sectional area per metre run.

1.3.4 Tolerances

1.3.4.1 Tolerance on size of mesh— The number of spaces between the external wires in a sheet or roll shall be determined by the nominal pitch. The centre-to-centre distance between two adjacent wires shall not vary by more than 7.5 percent from the nominal pitch. The maximum variation in the size of any mesh shall be not more than 5 percent over or under the specified size, and the average mesh size shall be such that the

total number of meshes contained in a sheet or roll is not less than that determined by the nominal pitch.

1.3.4.2 Tolerance on size of sheet— when fabric is required to be cut to specified dimensions, the tolerance shall be as follows:

- | | |
|----------------------|-------------------------------|
| a) for dimensions of | 25 mm under or over |
| 5 m and under | the specified dimensions |
| b) For dimensions | ½ percent under or |
| over 5 m | over the specified dimension. |

NOTE— These are tolerances for manufacture and supply and are not applicable for fabrication.

1.3.4.3 Tolerance on weight of fabric— The tolerance on the weight of fabric shall be as follows:

- | | |
|---|--------------|
| a) When the specified weight | ± 6 percent |
| is not stated to be either a maximum or a minimum | |
| b) When the specified weight | + 0 |
| is stated to be maximum | - 12 percent |
| c) When the specified weight | - 12 percent |
| is stated to be a minimum | - 0 |

SECTION 2
Detailing Functions

SECTION 2

DETAILING FUNCTIONS

2.1 General— In preparing drawings and bending schedules, the following factors shall be kept in view:

- a) The engineer's design and the design requirements;
- b) The cutting and bending of the reinforcement;
- c) The placing and wiring in position of reinforcement;
- d) The maintaining of the position of reinforcement;
- e) The preassembly of cages;
- f) Concreting;
- g) The accommodation of other trades and services;
- h) The measurement of quantities; and
- j) Economy in the use of steel.

2.2 Design— The following requirements of the designer shall be borne in mind:

- a) The quantity, location and cover of steel reinforcement should be simply, correctly and clearly shown.
- b) The placing drawings and bending schedules should be adequately cross-referenced, easily read and capable of easy checking in the drawing office and on site.
- c) It should be possible to locate a detail readily, should a doubt arise.
- d) One detailer should be able to take over from another with a minimum of delay and direction.
- e) Detailing should be done in such a way that secondary stresses caused by support conditions, shrinkage, temperature variations, bursting effects of laps and splices, and stress concentrations arising from hooks and bends are counteracted.

2.3 Cutting and Bending— Prepare bending schedules on standard size sheets small enough to facilitate handling by clerical, fabrication and placing personnel.

Standardize cutting lengths and ensure that bending details are simple and easy to read. So compile the schedules that delivery of the required reinforcement for each component can be effected without the need for abstracting from schedules.

The system of bar-referencing should be coherent and systematic, and should lend itself to easy identification and to use in computer systems, if necessary.

2.4 Placing and Wiring in Position— Ensure that drawings are simple, pictorially clear, and adequately detailed to enable the fixer to place bars exactly where required. Avoid crowding drawings with information by detailing by components and also if necessary by preparing separate details for bottom and top steel in slabs. Ensure that reinforcing steel that connects elements to be cast at different times is so detailed that it is included with the portion to be cast first, for example, splice bars for columns, continuity reinforcing for beams and slabs to be cast in portions. If the order of casting is not clear, detail splices in one of the sections with suitable cross-references. Where the complexity of the detail is such that an out of the ordinary sequence is required to place the reinforcement, ensure that such sequence is shown on the detail.

2.5 Maintaining Position of Reinforcement— Reinforcement that has been placed and wired in position should not be displaced before or during the concreting operation. Ensure that bar supports and cover blocks are so scheduled or specified as to maintain correct bottom and side cover and that high chairs and stools are detailed to support upper reinforcement mats at the correct level.

2.6 Preassembly of Cages and Mats— Where required, so detail the reinforcement to components such as columns, foundations, beams, and walls that it can be conveniently preassembled before being placed in position. Ensure that assembled units are sturdy enough to stand up to handling and erection, and that they are not so heavy that they cannot be lifted by the men or equipment available for the work.

2.7 Concreting— Ensure that the reinforcement can be so spaced as to allow placing and efficient consolidation of the concrete.

2.8 Other Trades and Services— Take note of the positions of down pipes (especially inlets and outlets), sleeves, pipes, and electrical conduits, whether shown on the structural layout or not. To avoid site difficulties, show them on the reinforcement details where necessary.

2.9 Measurement of Quantities— It is important that the quantity surveyor and the contractor should be able to compute the mass of

steel used at any stage in a contract. Bending schedules prepared as recommended in 2.3 will assist in meeting this requirement. Ensure that placing drawings and bending schedules are adequately cross-referenced and that all revisions are suitably recorded. If, in the case of a revision, there is any possibility of doubt, prepare separate schedules showing only the revision, with adequate cross-referencing.

2.10 Economy in Use of Steel — The type of steel used is generally specified by the designer but

bear in mind that up to one-third of the mass of steel can be saved by using high tensile steel instead of mild steel. The saving can be considerable as the difference of cost between the rates for mild steel and high tensile steel placed in position is relatively small. Furthermore, as the rates for small diameters are higher than those for large diameters, it is desirable to use the largest available size of bar within the design requirements. Larger bars also produce stiffer cages and are not easily displaced.

SECTION 3
Structural Drawing for Detailing

SECTION 3

STRUCTURAL DRAWING FOR DETAILING

3.1 Size of Drawing—The structural drawing for a large project should generally be of one size, for convenience both in the drawing office and on the site. The preferred sizes of drawing sheets are given in Table 3.1.

TABLE 3.1 DRAWING SHEET SIZES

| Sl. No. | DESIGNATION | TRIMMED SIZE | UNTRIMMED SIZE (Min) |
|---------|-------------|--------------|----------------------|
| (1) | (2) | (3) | (4) |
| | | mm × mm | mm × mm |
| i) | A0 | 841 × 1189 | 880 × 1230 |
| ii) | A1 | 594 × 841 | 625 × 880 |
| iii) | A2 | 420 × 594 | 450 × 625 |
| iv) | A3 | 297 × 420 | 330 × 450 |
| v) | A4 | 210 × 297 | 240 × 330 |
| vi) | A5 | 148 × 210 | 165 × 240 |

3.1.1 The dimensions recommended for all margins and the divisions of drawing sheets into zones are given in Fig. 3.1 (A to F).

3.1.1.1 The title block is an important feature in a drawing and should be placed at the bottom right-hand corner of the sheet, where it is readily seen when the prints are folded in the prescribed manner. The size of the title block recommended is 185 × 65 mm.

3.1.2 Separate sheets should be used for each type of structural member or unit so that a floor slab would be detailed on one sheet, beams on another, and columns on a further sheet, etc. Alternatively, for small jobs each standard size sheet could be used to detail one floor of the structure so that the ground floor slab, beams and columns could be detailed on one sheet and the first floor members on another.

3.1.3 Layout—There cannot be a single standard layout for the detailing of reinforced concrete drawings. However, it is the usual practice to draw the (key) plan in the upper left hand corner of the sheet, with the elevations and details below and on to the right side of the plan. Schedules and bending details are placed in the upper right corner of the drawing. Figure 3.2 gives a broad outline of layout recommended. In large projects, the bending schedule can be omitted from individual drawings and a separate bending schedule drawing may be prepared.

3.2 Scale of Drawing—Scales shall be so chosen as to bring out the details clearly and to keep the drawings within workable size. The choice of scale will depend at the discretion of the

detailer/designer and no general recommendations can be given in this respect. Some commonly used scales are given below as examples:

Plan — 1 : 100, 1 : 50

Elevation.— 1 : 5, 1 : 30

Sections — 1 : 50, 1 : 30, 1 : 25, 1 : 20, 1 : 15, 1 : 10

3.3 Information to be Shown on Structural Drawings

3.3.1 The overall sizes of the concrete members shall include the sizes of any necessary chamfers and fillets at corners. Also, the exact position, shape, size and spacing of the reinforcement within concrete members, as well as the required dimensions of the concrete cover to the reinforcement shall be given.

3.3.2 The position of any holes required in the members for service pipes and details of any pipes or other fixings to be cast-in with the concrete, and also, the position and details of construction joints and special recesses, etc, shall be indicated.

3.3.3 When foundations or ground floor slabs are detailed, information regarding the underside conditions shall be shown, such as the use of waterproof paper, the thickness of blinding (the lean layer of concrete), if required.

3.3.4 Notes should be used freely on detailed drawings. The most important being the 'bar marks' which give information about each, or a series of similar reinforcing bars. The notes should be concise and precise, and shall not be ambiguous. The notes which apply to the whole drawings, such as the specifications of the concrete to be used, size of chamfers and fillets, and concrete cover, etc, can be placed under a general heading at the bottom or side of the drawing.

3.3.5 The beams, wall slabs, floor slabs and columns, etc, the main dimensions of the structure, such as the distances between columns, heights between floors, beam and column sizes, and floor and wall thicknesses, etc, as calculated by the design engineer shall also be shown on the drawings.

Sections shall be drawn to at least twice the scale of plans or elevations to which they refer, while complicated joints such as may occur at the intersections of columns and beams may be detailed to larger scale, say 1 : 4.

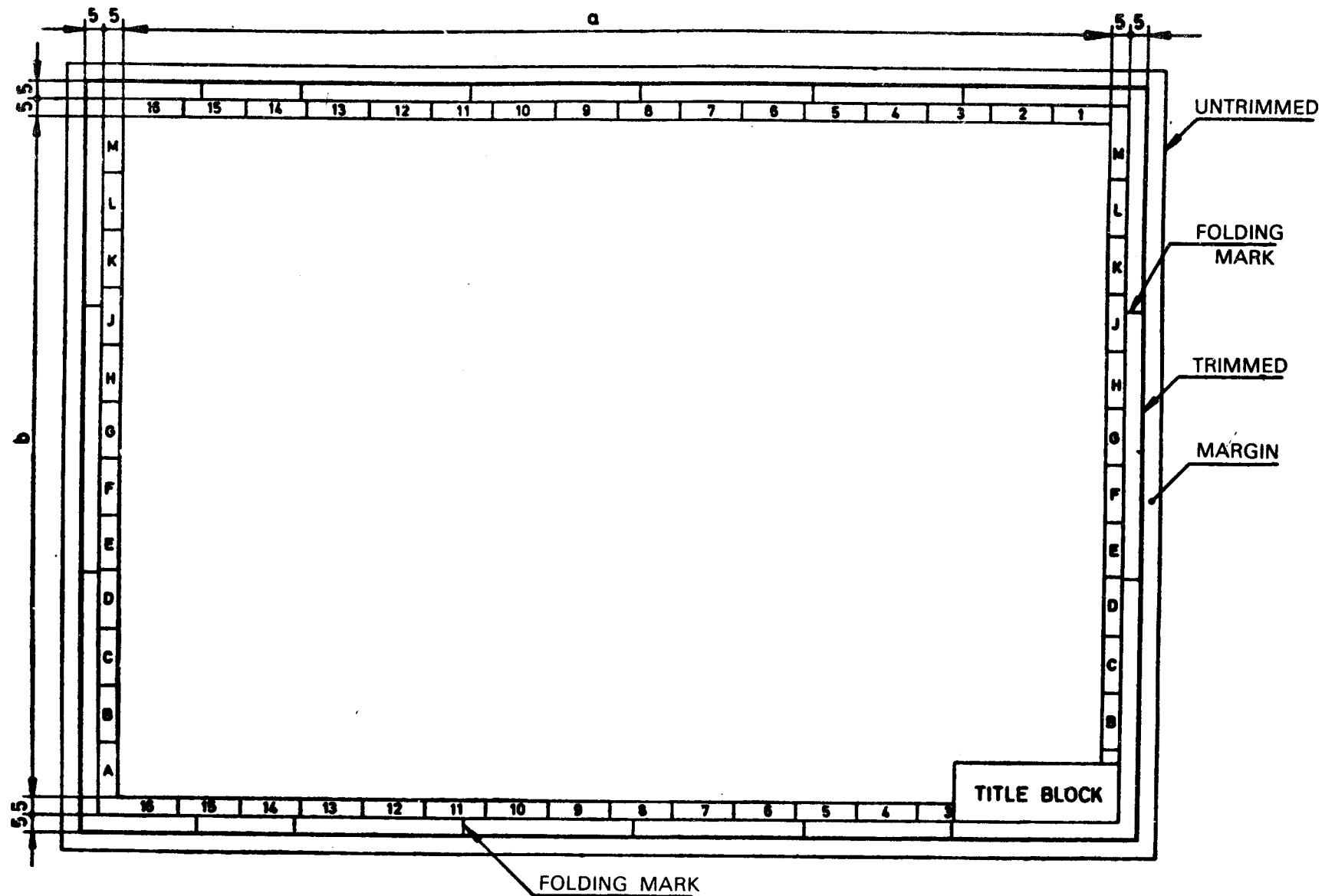

FOLDING MARK

All dimensions in millimetres.
3.1A AO SHEET LAYOUT

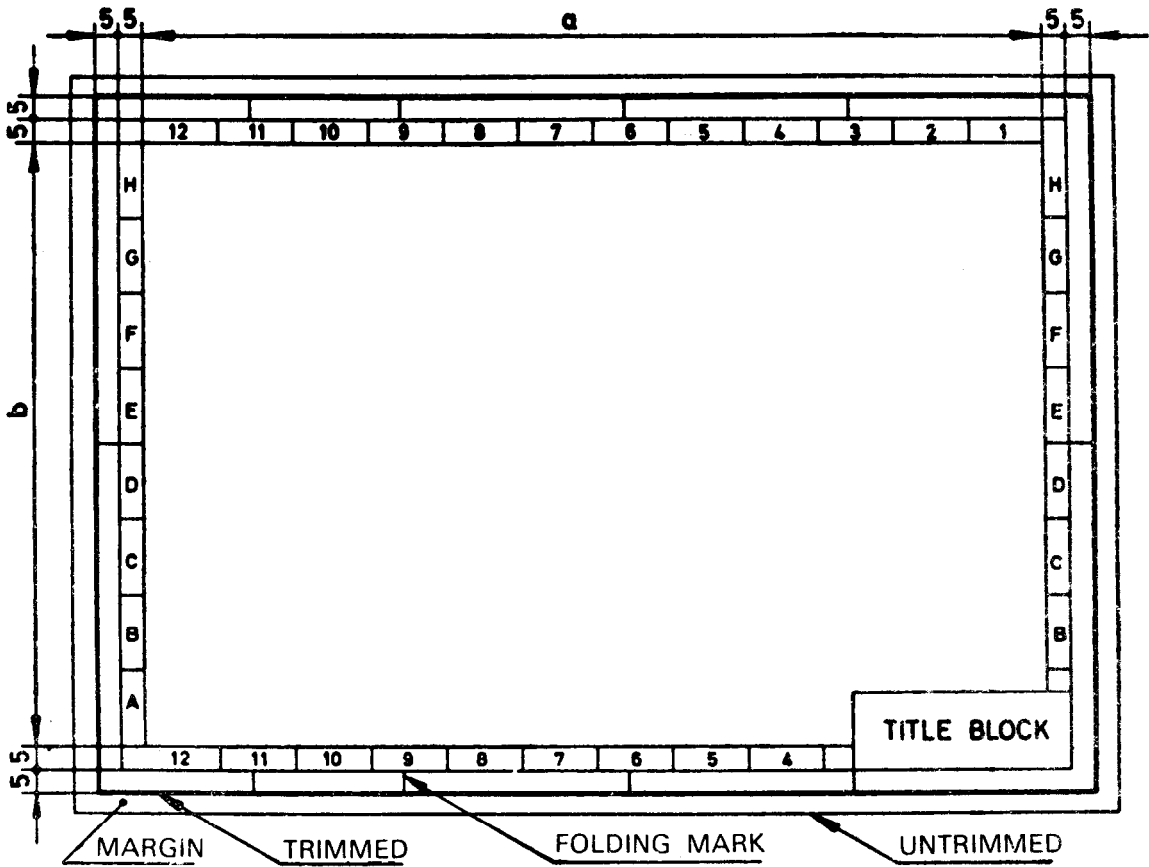

All dimensions in millimetres.

3.1B A1 SHEET LAYOUT

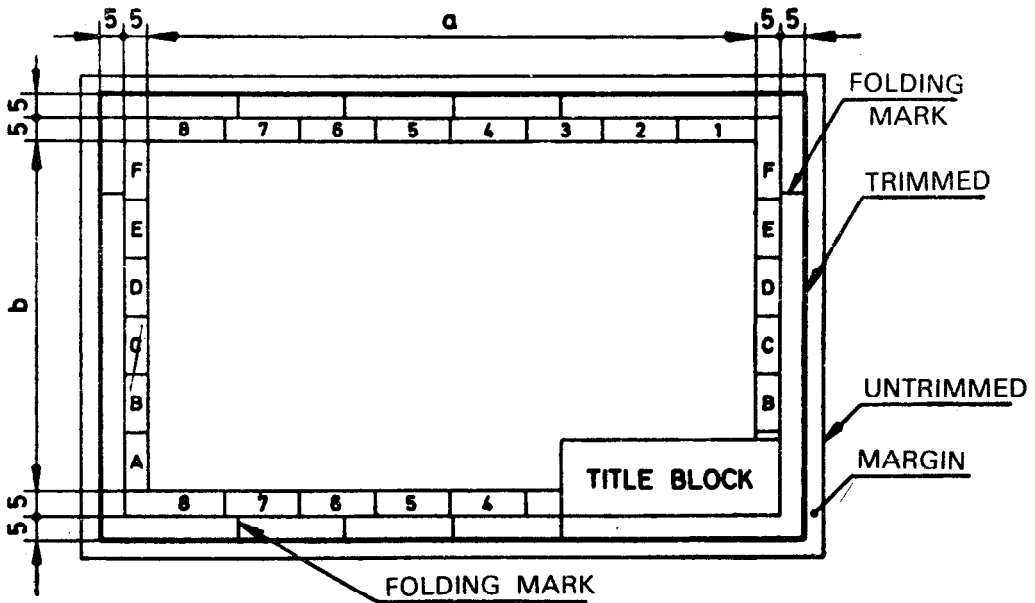

All dimensions in millimetres.

3.1C A2 SHEET LAYOUT

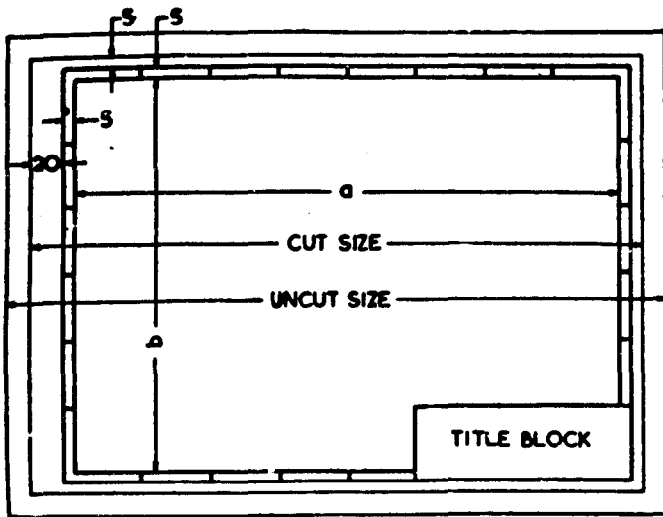

3.1D A3 SIZE

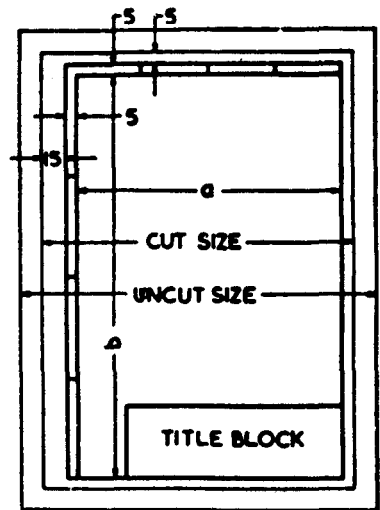

3.1E A4 SIZE

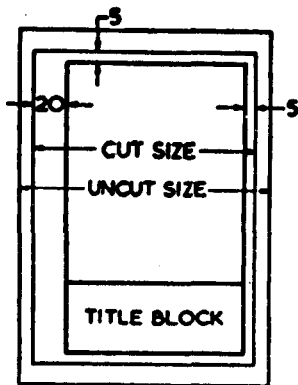

3.1F A5 SIZE

DIVISION OF ZONES

| DIVISION | | SHEET SIZE | | | | | NO ZONING |
|---------------|---|------------|----|----|----|----|-----------|
| | | A0 | A1 | A2 | A3 | A4 | |
| No. OF ZONING | a | 16 | 12 | 8 | 8 | 4 | |
| | b | 12 | 8 | 6 | 6 | 4 | |

3.1G DIVISION OF ZONES

All dimensions in millimetres.

FIG. 3.1 MARGINS AND DIVISION OF ZONES FOR DIFFERENT DRAWING SHEETS

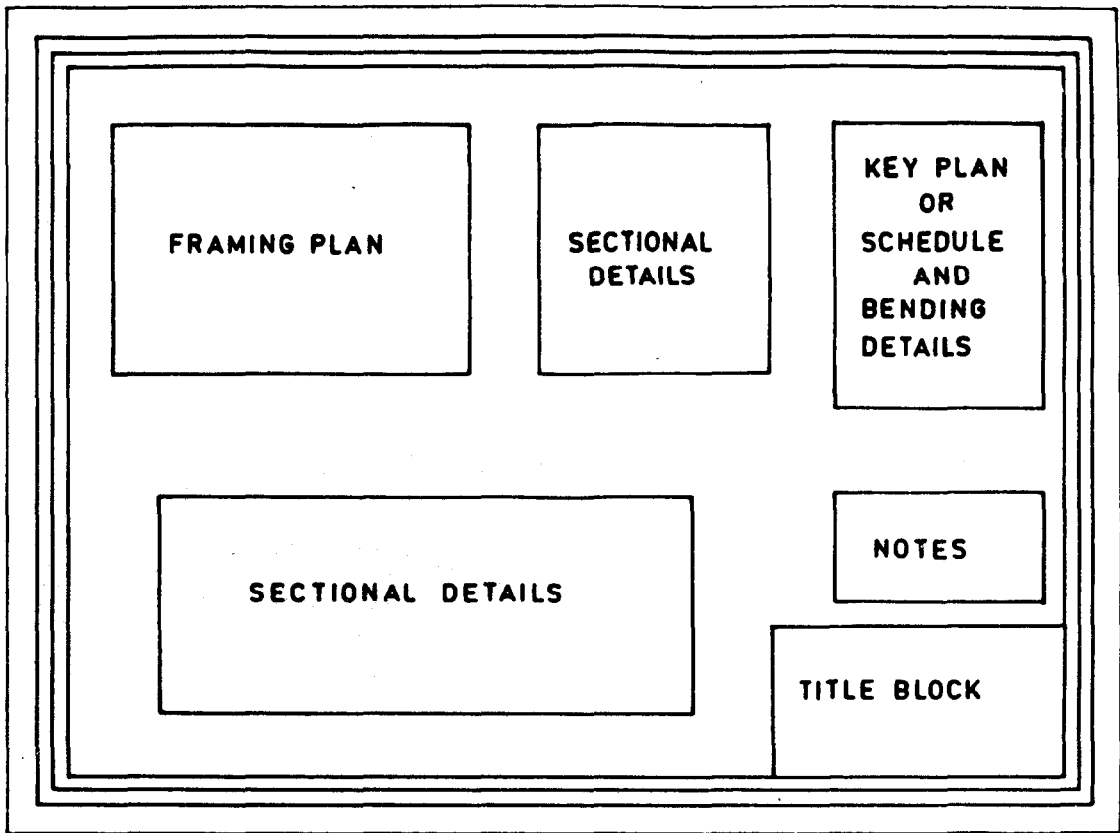

FIG. 3.2 TYPICAL LAYOUT OF A DRAWING

3.3.6 Structural drawings prepared by the designer shall show details of reinforcement and all other information needed for detailing the reinforcement. The drawings shall also indicate, by separate notes, live loads, concrete strength, quality and grade of steel, number of bars to be lapped and lengths of the laps, and if necessary special instructions regarding erection of formwork, fabrication and placing of steel.

3.3.7 It is convenient to detail the reinforcement by units which generally consist of footings, walls, columns, each floor and roof. A separate structural drawing supplemented by bar bending schedule should preferably be made for each unit. For small structures, the entire requirements may be handled as one unit. For a large project a particular unit such as floor may be divided to correspond with the construction schedule.

3.3.8 To ensure that all the reinforcement is properly placed or positioned in a unit, longitudinal section or cross-section should be shown in addition to plan and elevation of the unit on which the bars are shown.

3.3.9 The drawing should be complete and clear so as to leave no doubt on any point of construction. Complete and accurate dimensions shall be shown. Clear and adequate details for

special and unusual condition shall be given to ensure proper placing of reinforcement. Details of covers and intersections of walls, construction joints, window and door openings, and similar special features should be shown in the relevant drawings alongwith sketches, if necessary.

3.3.10 For clear demarcation of reinforcement bars, those in the near face shall be shown in full lines and those that are placed in the far face shall be shown in dotted lines.

3.3.11 All bars, straight or bent requiring hooks bends, shall be properly designated by the designer or a note to this effect included in the drawing.

3.3.12 Lengths of laps, points of bend, cut-off points and extension of bars should be specified by the designer. The dimensions $L/7$, $L/5$ and $L/4$, etc. shown on typical drawings shall not be used unless justified by structural analysis.

3.3.13 Wherever possible, all control and construction joints should be indicated on structural drawings and constructional details provided for such joints.

3.3.14 *Notes and Instructions* – Any ambiguity and scope for misinterpretation of instructions shall be avoided. All instructions shall be in imperative form, specific, brief and clear.

3.3.15 Schedules — The reinforcement details of slabs, beams, columns and many other parts of structures may be effectively shown on working drawings in a tabular form, known as a schedule (see Section 5).

3.4 Symbols and Abbreviations — Symbols and abbreviations to be adopted in the drawings for reinforced concrete construction are given in 3.4.1 to 3.5.6. All reinforcement bars used in the structures shall be suitably designated and numbered both on drawing and schedule.

3.4.1 Symbols Relating to Cross-Sectional Shape and Size of Reinforcement

- a) ϕ plain round bar or diameter of plain round bar;
- b) \square plain square bar or side of plain square bar; and
- c) # deformed bar (including square twisted bar) or nominal size (equivalent diameter or side) of the deformed bar (see Note under 3.4.5).

3.4.2 Symbols Relating to Shape of the Bar along its Lengths

| | |
|-----|---------------|
| Alt | Alternate bar |
| Bt | Bent bar |
| B | Bottom bar |
| min | Minimum |
| max | Maximum |
| St | Straight bar |
| Stp | Stirrup |
| Sp | Spiral |
| Ct | Column tie |
| T | Top bar |

NOTE: Alternatively, all symbols may be in capitals.

3.4.3 Symbols Relating to Position and Direction

| | |
|----|--------------------------|
| EW | Each way |
| @ | Spacing centre-to-centre |

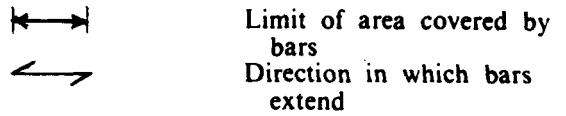

3.4.4 Symbols Relating to Various Structural Members

| | |
|---------|-------------------|
| Bm or B | Beams |
| Col | Column(s) |
| Fg | Footing(s) |
| GR | Girders |
| JT | Joints(s) |
| LL | Lintel(s) |
| LB | Lintel beam(s) |
| Sb or S | Slab(s) |
| WL | Longitudinal wall |
| Wx | Cross wall |
| £ | Centre line |

NOTE: Alternatively, all symbols may be in capitals.

3.4.5 The symbols, abbreviations and notes shall be used in a manner that will not create any ambiguity. A few examples for representing diameter, spacing, number of bars, etc., are illustrated below:

- a) # 20@ 200 means 20 mm diameter deformed bars spaced at 200 mm centre-to-centre.
- b) 20-# 12 means 20 numbers of 12 mm diameter deformed bars.
- c) ϕ 32-St-12 EW means 12 numbers of 32 mm diameter plain round straight bars in each direction.

NOTE: — The symbol relating to cross-sectional shape and size — ϕ or # is used on the left hand side of the numerical value of the diameter to avoid confusion that it may be interpreted as the number of times the diameter if used on the right hand side of the numerical value of the diameter.

3.4.6 The use of the same type of line for the same purpose considerably enhances the clarity and usefulness of the drawing. The following graphical symbols are suggested:

| Symbol | Designation/Description |
|-----------|--|
| ————— | Concrete line (thin) |
| - - - - - | Unexposed concrete or masonry wall line (thin) |
| ————— | Reinforcement (thick) |
| - - - - - | Reinforcement in a different layer (thick). |
| ● | Section of a reinforcing bar |
| - - - - - | Centre line |

Symbol

Designation/Description

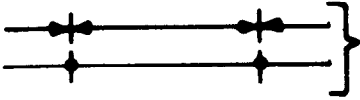

Dimension line

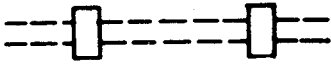

Concrete beam framing into column which extends through floor

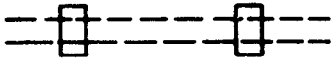

Concrete beam framing into column which stops at floor



Bar shown bent at right angle to the paper



Bar with hooks



Bar with 90° bends

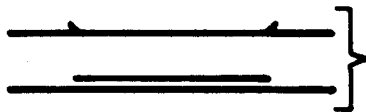

Bars shown separated on the drawing



One sheet of welded fabric on plan

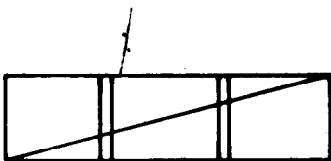

Identical sheets of welded fabric in a row

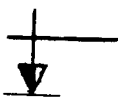

Level mark in elevation









Level mark in plan

3.4.7 Additional drawing conventions for use on drawings for reinforcement as suggested in ISO : 3766-1977 'Building and civil engineering

drawings—Symbols for concrete reinforcement' is reproduced in Table 3.2.

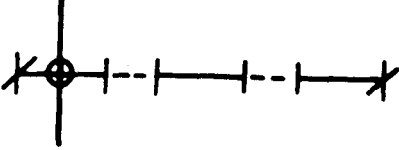
TABLE 3.2 DRAWING CONVENTIONS

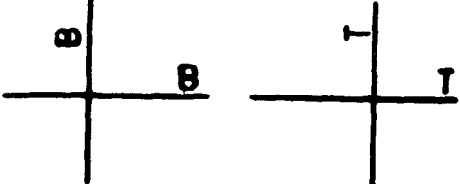
| Sl No. | CONVENTION | SYMBOL |
|--------|---|--|
| (1) | (2) | (3) |
| i) | Bends shall normally be drawn to scale |  |
| | Bends with the smallest permitted bend radius may be drawn with intersecting straight lines |  |
| ii) | A bundle of bars may be drawn with a single line, end markings indicating the number of bars in the bundle |  |
| | <i>Example</i> : Bundle with three identical bars | |
| iii) | Each set of identical bars, stirrups or ties shall be indicated by one bar, stirrup or tie drawn with continuous extra-thick lines, with a continuous thin across the set terminated by short oblique lines to mark the extreme bars, stirrups or ties. |  |
| | A circle drawn with a continuous thin line connects the 'set line' with the correct bar, stirrup or tie. | |
| iv) | Bars placed in groups, each group spaced over the same distance and containing an identical number of identical bars |  |
| v) | Two-way reinforcement shall be shown in section, or marked with text or symbol in order to show the direction of bars in the outside layer on each face of the construction in plan or elevation |  |
| vi) | On plan drawing for simple arrangements, the top-layer and bottom-layer reinforcement shall have letter indicating the location of the layer added to the symbols |  |

(Continued)

TABLE 3.2 DRAWING CONVENTIONS (Contd.)

| Sl. No. | CONVENTION | SYMBOL |
|--|--|--------|
| (1) | <p>If end marks are used, the end marks shall be drawn upwards or to the left for the bottom-layer and downwards or to the right for the toplayer</p> <p>(B—bottom T—top)</p> | |
| vii) | <p>On elevations of walls with reinforcement on both faces, the reinforcement shall have letters added to the symbols, indicating the location of the layer</p> | |
| <p>If end marks are used, the end marks shall be drawn upwards or to the left for face reinforcement, and downwards or to the right for near face reinforcement.</p> <p>(NF—near face FF—far face)</p> | | |
| viii) | <p>If the arrangement of the reinforcement is not clearly shown by the section, an additional sketch showing the reinforcement may be drawn outside the section.</p> | |
| ix) | <p>All the types of stirrups or ties present shall be indicated on the drawing. If the arrangement is complicated, it may be clarified by the aid of a sketch in connection with the notation.</p> | |

3.5 Marks for Parts of Buildings

3.5.1 Marks are used to designate the different structural members of a structure. Different structural members of a structure shall be marked using symbols, abbreviations and notations indicated in succeeding clauses and in the manner indicated in other clauses.

3.5.2 A key framing plan shall be prepared to a convenient scale and the two axes marked one side with alphabets *A, B, C*, etc, and the other with numbers (see Fig. 3.3). Normally with rectangular pattern, the same key framing plan may be used for all floors. However, if arrangement of beams vary for different floors a separate key framing plan with grid arrangement and areas may be used for each of the floor. The floors shall be specified in accordance with the requirements of IS : 2332-1973 'Specifications for nomenclature of floors and storeys' and abbreviations *BT* and *MZ* shall be used for basement and mezzanine, respectively, for example:

BT Basement
MZ Mezzanine

Floor 1

Floor 2

3.5.3 Columns—Columns and foundations shall be specified by grid arrangement giving reference to the floor, for example (see Fig. 3.3A).

FG Col E1 Footing for Column *E1*

Col 2E1 Column *E1* at floor 2

(that is, column for storey 2, or column between floor 2 and 3).

3.5.4 Beams, slabs and lintels, and tie beams shall be consecutively numbered from left-hand top corner (see Fig. 3.3A).

3.5.5 If longitudinal section of the beam is shown, the grid of the column or number of the column supporting the beam is being detailed shall be as indicated as in fig. 3.3B and, if possible, inset on the drawing showing the key framing plan. On the other hand if a beam schedule is included, a table [see Fig. 3.3C] may be prepared and inset on the drawing showing the key framing plan [see Fig. 3.3A].

3.5.5.1 Beams or slabs that are similar may be given in the same number.

3.5.6 Walls—Marking of walls shall be made in the serial order starting from top left corner of plan and proceeding towards the right, followed by subsequent rows in order. Longitudinal walls and cross-walls shall be marked separately (see Fig. 3.4) and identified in the drawing with reference to the serial number of the floor.

Example

2 *WL* — 1 Longitudinal wall No. 1 at floor 2 (between floor 2 and 3).

4 *WX* — 3 Cross-wall No. 3 at floor 4 (between floor 4 and 5).

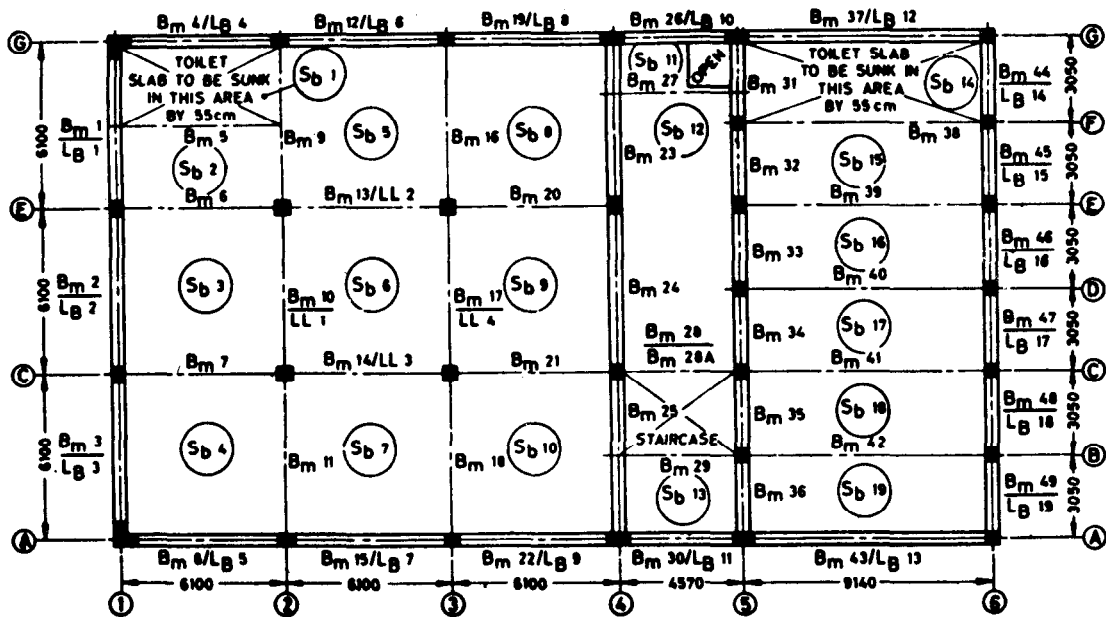

3.3A.

FIG. 3.3 TYPICAL ARRANGEMENT FOR THE KEY FRAMING PLAN AND MARKING DIFFERENT STRUCTURAL MEMBERS (Continued)

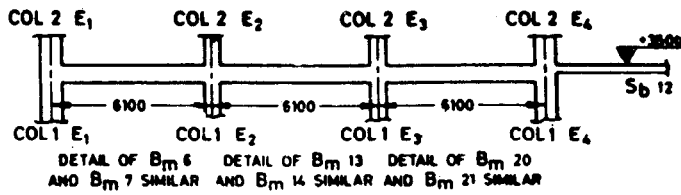

3.3B

| Beam No. | Floor | Spanning Between | At Level mm |
|--------------------------------------|-------|---------------------------------|----------------|
| B _m 1 | 1 | E ₁ G ₁ | +3500 |
| B _m 14 | 1 | C ₂ C ₃ | +3500 |
| B _m 27 | 1 | B ₂₂ B ₃₁ | +3500 |
| B _m 28 | 1 | C ₄ C ₅ | +3500 |
| B _m 28A (Landing Beam) | 1 | C ₄ C ₅ | +1750 |
| B _m 29 | 1 | B ₆ B ₂₅ | +3500 |
| LB 1 | 1 | E ₁ G ₁ | +2440 |
| LB 9 | 1 | A ₃ A ₄ | +2440 |

3.3C

FIG. 3.3 TYPICAL ARRANGEMENT FOR THE KEY FRAMING PLAN AND MARKING DIFFERENT STRUCTURAL MEMBERS

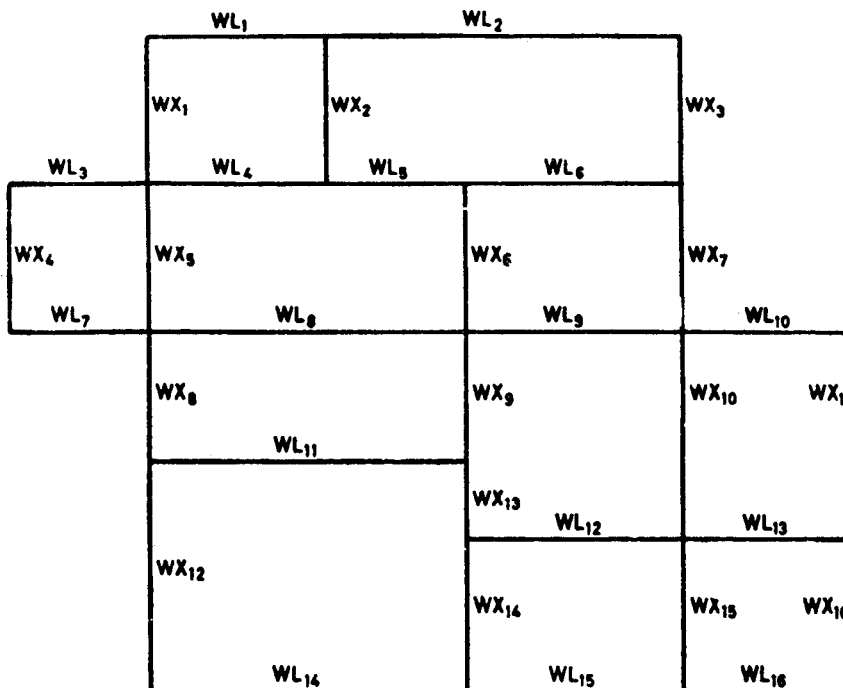

FIG. 3.4 TYPICAL MARKING DETAILS FOR WALLS

SECTION 4
General Detailing Requirements

SECTION 4

GENERAL DETAILING REQUIREMENTS

4.1 Cover — Reinforcement shall have concrete cover (nominal) and the thickness of such cover (exclusive of plaster or other decorative finish) shall be as follows:

- a) At each end of reinforcing bar not less than 25 mm, or twice the diameter of such bar whichever is greater;
- b) For a longitudinal reinforcing bar in a column not less than 40 mm or the diameter of such bar whichever is greater. In the case of columns with a minimum dimension of 20 mm or under, whose reinforcing bars do not exceed 12 mm, the cover may be reduced to 25 mm;
- c) For longitudinal reinforcing bar in a beam not less than 25 mm or the diameter of such bar, whichever is greater;
- d) For tensile, compressive, shear or other reinforcement in a slab not less than 15 mm or the diameter of such reinforcement, whichever is greater; and
- e) For any other reinforcement not less than 15 mm or the diameter of such reinforcement, whichever is greater.

NOTE — The values of cover suggested are nominal cover as specified in the drawings. The cover shall in no case be reduced by more than one-third of the specified cover or 5 mm whichever is less. During construction it is essential to ensure that these tolerances are met.

4.1.1 Increased cover thickness may be provided when the surfaces of concrete members are exposed to the action of harmful chemicals (as in the case of concrete in contact with earth contaminated with such chemicals), acid, vapour, saline atmosphere, sulphurous smoke (as in the case of steam-operated railways), etc, and such increase of cover may be between 15 and 50 mm over the values given in 4.1 above as may be specified by the Engineer-in-Charge. However, in no case cover should exceed 75 mm.

4.1.2 For reinforced concrete members of marine structures totally immersed in sea water, the cover shall be 40 mm more than that specified in 4.1, but total cover should not exceed 75 mm.

4.1.3 For reinforced concrete structures/ structural members, periodically immersed in sea water or subject to sea spray, the cover of concrete shall be 50 mm more than that specified in 4.1, but total cover should not exceed 75 mm.

4.1.4 For concrete of grade M25 and above, the additional thickness of cover specified in 4.1.1 to 4.1.3 may be reduced by half.

4.2 Development of Stress in Reinforcement

4.2.1 Development Length of Bars in Tension or Compression — The calculated tension or compression in any bar at any section shall be developed on each side of the section by an appropriate development length or end anchorage or by a combination thereof.

NOTE — Development length is the embedded length of reinforcement required to develop the design strength of the reinforcement at a critical section. Critical sections for development of reinforcement in flexural members are at points of maximum stress and at points within the span where adjacent reinforcement terminates, or is bent. Provisions of 4.6.3 (c) should be satisfied at simple supports and at points of inflection.

4.2.2 The development length L_d is given by:

$$L_d = \frac{\phi \sigma_s}{4 \tau_{bd}}$$

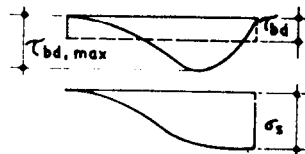
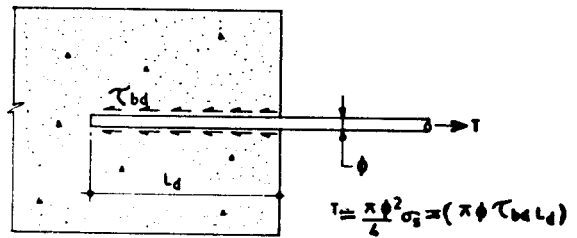

where

ϕ = nominal diameter of the bar,

σ_s = stress in bar at the section considered at design load, and

τ_{bd} = design bond stress for bars in tension given in 4.2.2.1.

NOTE 1 — The development includes anchorage values of hooks in tension reinforcement (see 4.3.1).

NOTE 2 — For bars of sections other than circular, the development length should be sufficient to develop the stress in the bar by bond.

4.2.2.1 Design bond stress in limit state design method for plain bars in tension shall be as follows:

| | | | | | | |
|--|-----|-----|-----|-----|-----|-----|
| Grade of concrete | M15 | M20 | M25 | M30 | M35 | M40 |
| Design bond stress τ_{bd} , N/mm ² | 1.0 | 1.2 | 1.4 | 1.5 | 1.7 | 1.9 |

For deformed bars, these values shall be increased by 60 percent. For bars in compression, the values of bond stresses for bars in tension shall be increased by 25 percent.

4.3 Anchoring Reinforcing Bars — It is important to note that when a bar is subjected to both tension and compression, the anchorage value should correspond to the one which gives the maximum value, and at the same time individual requirements (with respect to tension and compression) are also satisfied as specified in 4.3.1 to 4.3.3.

4.3.1 Anchoring Bars in Tension

4.3.1.1 Deformed bars may be anchored in straight lengths (without end anchorages), provided the development length requirements are

satisfied. Plain bars should not be normally anchored through straight lengths alone and should be provided with hooks.

4.3.1.2 Bends and hooks

- a) *Bends* — The anchorage value of a standard bend shall be taken as 4 times the diameter of the bar for each 45° bend subject to a maximum of 16 times the diameter of the bar.
- b) *Hooks* — The anchorage value of a standard U-type hook shall be equal to 16 times the diameter of the bar.

The anchorage values of standard hooks and bends for different bar diameters are given in Table 4.1.

4.3.2 Anchoring Bars in Compression — The anchorage length of straight bar in compression shall be equal to the development length of bars in compression as specified in 4.2.2. The projected length of hooks, bends and straight lengths beyond bends, if provided for a bar in compression, should be considered for development length (see Fig. 4.1).

TABLE 4.1 ANCHORAGE VALUE OF HOOKS AND BENDS

| | | | | | | | | | | | | |
|---------------------------------|-----|------|------|------|------|------|------|------|------|------|------|------|
| BAR DIAMETER, mm | 6 | 8 | 10 | 12 | 16 | 18 | 20 | 22 | 25 | 28 | 32 | 36 |
| ANCHORAGE VALUE OF HOOK, cm | 9.6 | 12.8 | 16.0 | 19.2 | 25.6 | 28.8 | 32.0 | 35.2 | 40.0 | 44.8 | 51.2 | 57.6 |
| ANCHORAGE VALUE OF 90° BEND, cm | 4.8 | 6.2 | 8.0 | 9.6 | 12.8 | 14.4 | 16.0 | 17.6 | 20.0 | 22.4 | 25.6 | 28.8 |

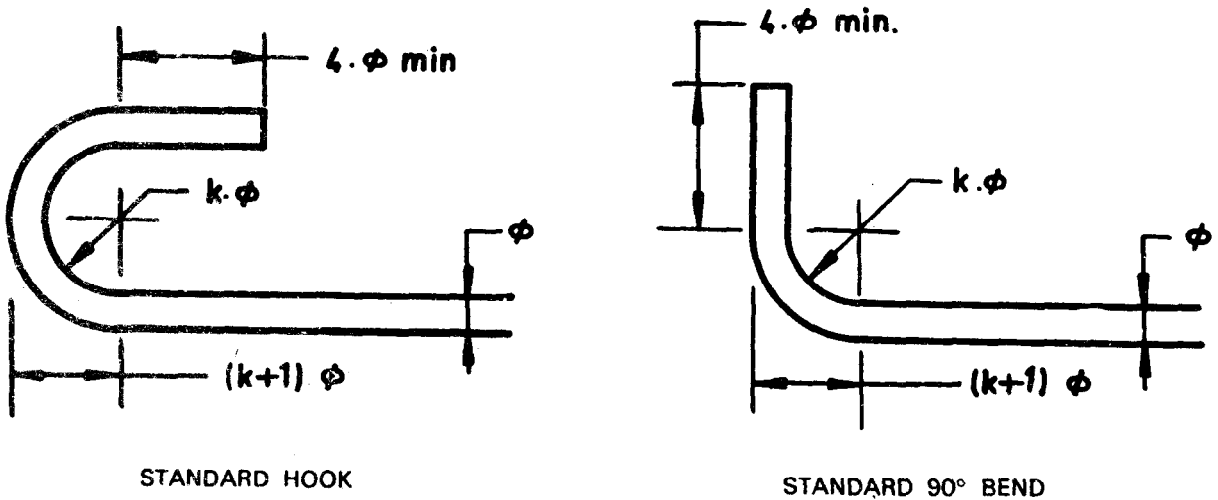

STANDARD HOOK AND BEND

| | |
|-------------------|--------------------|
| Type of Steel | Minimum Value of k |
| Mild steel | 2 |
| Cold-worked steel | 4 |

NOTE 1 — Table is applicable to all grades of reinforcement bars.

NOTE 2 — Hooks and bends shall conform to the details given above.

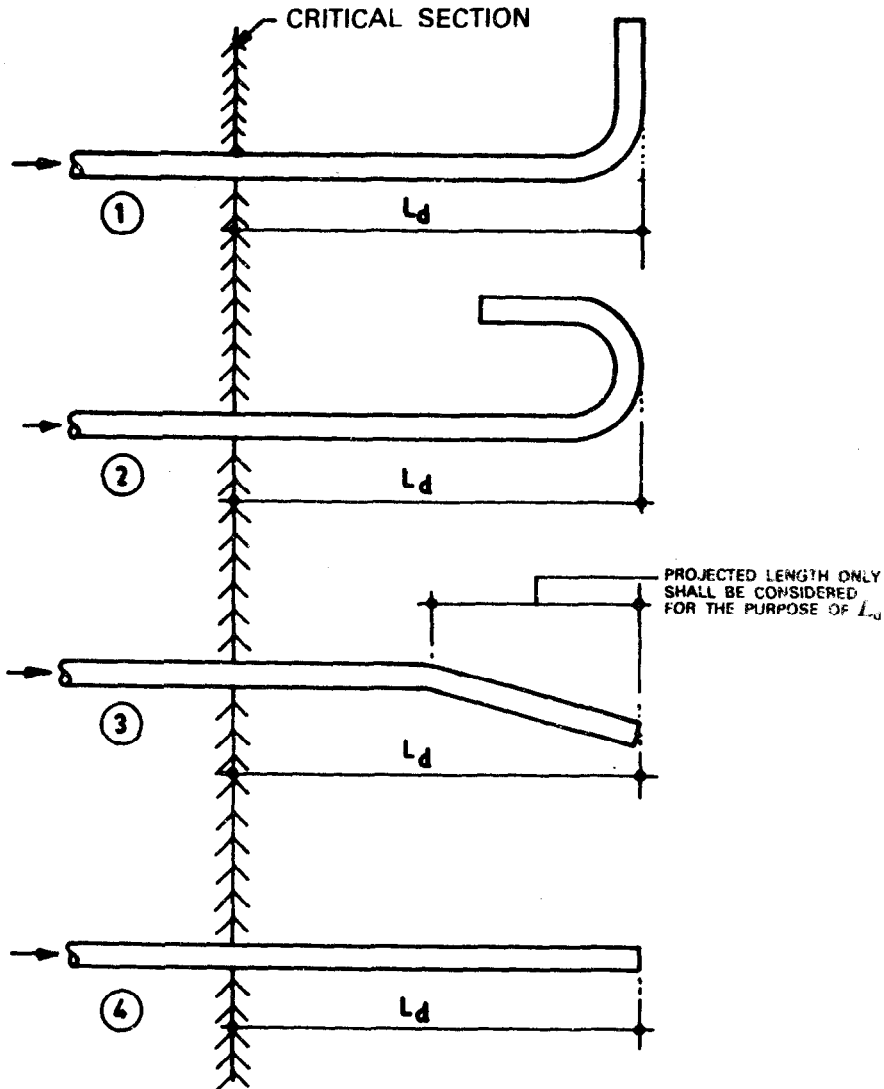

NOTE — In compression hooks and bends are ineffective and cannot be used as anchorage.

FIG. 4.1 DEVELOPMENT LENGTH IN COMPRESSION

4.3.3 The development length values for fully stressed bars in tension as well as compression based on 4.2.2 are given in Tables 4.2, 4.3 and 4.4.

NOTE — If the amount of steel provided at a design section is more than that required from design consideration, the development length given in Tables 4.2, 4.3 and 4.4 may be modified as:

$$L_{dm} = \frac{A_s \text{ required}}{A_s \text{ provided}}$$

Unless otherwise specified, L_{dm} modified development length should be used in detailing reinforcement.

4.3.4 Mechanical Devices for Anchorage — Any mechanical or other device capable of

developing the strength of the bar without damage to concrete may be used as anchorage with the approval of the Engineer-in-Charge.

4.3.5 Anchoring Shear Reinforcement

a) *Inclined bars* — The development length shall be as for bars in tension; this length shall be measured as under:

- 1) In tension zone, from the end of the sloping or inclined portion of the bar (see Fig. 4.2A), and

2) In the compression zone, from the mid depth of the beam (see Fig. 4.2B).

b) *Stirrups and ties* — Notwithstanding, any of the provisions of this Handbook, in case of secondary reinforcement, such as stirrups and transverse ties, complete development length and anchorage shall be deemed to have been provided when the bar is bent through an angle of at least 90° round a bar of at least its own diameter and is continued beyond the end of the curve for a length of at least eight diameters, or when the bar is

bent through an angle of 135° and is continued beyond the end of the curve for a length of at least six bar diameters or when the bar is bent through an angle of 180° and is continued beyond the end of the curve for a length of at least four bar diameters.

4.3.6 *Special Members* — Adequate end anchorage shall be provided for tension reinforcement in flexural members where reinforcement stress is not directly proportional to moment, such as sloped, stepped or tapered footings, brackets, deep beams and members in

TABLE 4.2 DEVELOPMENT LENGTH FOR FULLY STRESSED PLAIN BARS

$f_y = 250 \text{ N/mm}^2$ for bars up to 20 mm diameter

= 240 N/mm² for bars over 20 mm diameter

(Tabulated values are in centimetres)

| BAR DIAMETER | TENSION BARS FOR GRADE OF CONCRETE | | | | COMPRESSION BARS FOR GRADE OF CONCRETE | | | |
|--------------|------------------------------------|-------|-------|-------|--|-------|-------|-------|
| | M15 | M20 | M25 | M30 | M15 | M20 | M25 | M30 |
| (1) mm | (2) | (3) | (4) | (5) | (6) | (7) | (8) | (9) |
| 6 | 32.6 | 27.2 | 23.3 | 21.8 | 26.1 | 21.8 | 18.6 | 17.4 |
| 8 | 43.5 | 36.3 | 31.1 | 29.0 | 34.8 | 29.0 | 24.9 | 23.2 |
| 10 | 54.4 | 45.3 | 38.8 | 36.3 | 43.5 | 36.3 | 31.1 | 29.0 |
| 12 | 65.3 | 54.4 | 46.6 | 43.5 | 52.2 | 43.5 | 37.3 | 34.8 |
| 16 | 87.0 | 72.5 | 62.1 | 58.0 | 69.6 | 58.0 | 49.7 | 46.4 |
| 18 | 97.9 | 81.6 | 69.9 | 65.3 | 78.3 | 65.3 | 55.9 | 52.2 |
| 20 | 108.8 | 90.6 | 77.7 | 72.5 | 87.0 | 72.5 | 62.1 | 58.0 |
| 22 | 114.8 | 95.7 | 82.0 | 76.6 | 91.9 | 76.6 | 65.6 | 61.2 |
| 25 | 130.5 | 108.8 | 93.2 | 87.0 | 104.4 | 87.0 | 74.6 | 69.6 |
| 28 | 146.2 | 121.8 | 104.4 | 97.4 | 116.9 | 97.4 | 83.5 | 78.0 |
| 32 | 167.0 | 139.2 | 119.3 | 111.4 | 133.6 | 111.4 | 95.5 | 89.6 |
| 36 | 187.9 | 156.6 | 134.2 | 125.3 | 150.3 | 125.3 | 107.4 | 100.2 |

NOTE 1 — The development lengths given above are for a stress of 0.87 f_y in the bar.

NOTE 2 — It is important to note that hooks should normally be provided for plain bars in tension. Therefore, the straight length required in such cases is equal to the value taken from the table minus the anchorage value of hook.

TABLE 4.3 DEVELOPMENT LENGTH FOR FULLY STRESSED DEFORMED BARS

$f_y = 415 \text{ N/mm}^2$

(Tabulated values are in centimetres)

| BAR DIAMETER | TENSION BARS FOR GRADE OF CONCRETE | | | | COMPRESSION BARS FOR GRADE OF CONCRETE | | | |
|--------------|------------------------------------|-------|-------|-------|--|-------|-------|-------|
| | M15 | M20 | M25 | M30 | M15 | M20 | M25 | M30 |
| (1) mm | (2) | (3) | (4) | (5) | (6) | (7) | (8) | (9) |
| 6 | 33.8 | 28.2 | 24.2 | 22.6 | 27.1 | 22.6 | 19.3 | 18.1 |
| 8 | 45.1 | 37.6 | 32.2 | 30.1 | 36.1 | 30.1 | 25.8 | 24.1 |
| 10 | 56.4 | 47.0 | 40.3 | 37.6 | 45.1 | 37.6 | 32.2 | 30.1 |
| 12 | 67.7 | 56.4 | 48.4 | 45.1 | 54.2 | 45.1 | 38.7 | 36.1 |
| 16 | 90.3 | 75.2 | 64.5 | 60.2 | 72.2 | 60.2 | 51.6 | 48.1 |
| 18 | 101.5 | 84.6 | 72.5 | 67.7 | 81.2 | 67.7 | 58.0 | 54.2 |
| 20 | 112.8 | 94.0 | 80.6 | 75.2 | 90.3 | 75.2 | 64.5 | 60.2 |
| 22 | 124.1 | 103.4 | 88.7 | 82.7 | 99.3 | 82.7 | 70.9 | 66.2 |
| 25 | 141.0 | 117.5 | 100.7 | 94.0 | 112.8 | 94.0 | 80.6 | 75.2 |
| 28 | 158.0 | 131.6 | 112.8 | 105.3 | 126.4 | 105.3 | 90.3 | 84.2 |
| 32 | 180.5 | 150.4 | 128.9 | 120.3 | 144.4 | 120.3 | 103.2 | 96.3 |
| 36 | 203.1 | 169.3 | 145.0 | 135.4 | 162.5 | 135.4 | 116.1 | 108.3 |

NOTE — The development lengths given above are for a stress of 0.87 f_y in the bars.

TABLE 4.4 DEVELOPMENT LENGTH FOR FULLY STRESSED DEFORMED BARS

$f_y = 500 \text{ N/mm}^2$

(Tabulated values are in centimetres)

| BAR DIAMETER | TENSION BARS FOR GRADE OF CONCRETE | | | | COMPRESSION BARS FOR GRADE OF CONCRETE | | | |
|--------------|------------------------------------|-------|-------|-------|--|-------|-------|-------|
| | M15 | M20 | M25 | M30 | M15 | M20 | M25 | M30 |
| (1) mm | (2) | (3) | (4) | (5) | (6) | (7) | (8) | (9) |
| 6 | 40.8 | 34.0 | 29.1 | 27.2 | 32.6 | 27.2 | 23.3 | 21.8 |
| 8 | 54.4 | 45.3 | 38.8 | 36.3 | 43.5 | 36.3 | 31.1 | 29.0 |
| 10 | 68.0 | 56.6 | 48.5 | 45.3 | 54.4 | 45.3 | 38.8 | 36.3 |
| 12 | 81.6 | 68.0 | 58.3 | 54.4 | 65.3 | 54.4 | 46.6 | 43.5 |
| 16 | 108.8 | 90.6 | 77.7 | 72.5 | 87.0 | 72.5 | 62.1 | 58.0 |
| 18 | 122.3 | 102.0 | 87.4 | 81.6 | 97.9 | 81.6 | 69.9 | 65.3 |
| 20 | 135.9 | 113.3 | 97.1 | 90.6 | 108.8 | 90.6 | 77.7 | 72.5 |
| 22 | 149.5 | 124.6 | 106.8 | 99.7 | 119.6 | 99.7 | 85.4 | 79.8 |
| 25 | 169.9 | 141.6 | 121.4 | 113.3 | 135.9 | 113.3 | 97.1 | 90.6 |
| 28 | 190.3 | 158.6 | 135.9 | 126.9 | 152.3 | 126.9 | 108.8 | 101.5 |
| 32 | 217.5 | 181.3 | 155.4 | 145.0 | 174.0 | 145.0 | 124.3 | 116.0 |
| 36 | 244.7 | 203.9 | 174.8 | 163.1 | 195.8 | 163.1 | 139.8 | 130.5 |

NOTE — The development lengths given above are for a stress of $0.87 f_y$ in the bar.

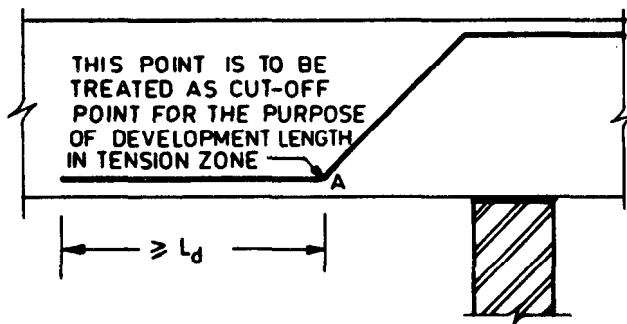

4.2A IN TENSION ZONE

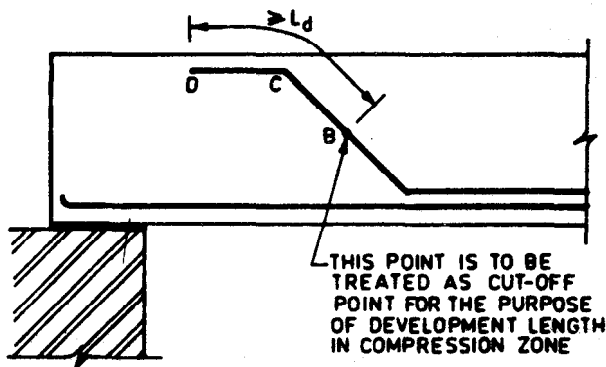

4.2B IN COMPRESSION ZONE

FIG. 4.2 ANCHORING INCLINED BENT-UP BARS

which the tension reinforcement is not parallel to the compression face.

4.4 Reinforcement Splicing — Splicing is required to transfer force from one bar to another. Methods of splicing include lapping (see 4.4.2), welding (see Appendix A) and mechanical means (see 4.4.3).

4.4.1 Where splices are provided for continuity in the reinforcing bars (tension bars in beams), they shall be as far as possible away from the sections of maximum stress and be staggered. It is recommended that splice in flexural members should not be at sections where the bending moment is more than 50 percent of the moment of resistance of the section. Not more than half the bars shall be spliced at a section.

Where more than one half of the bars are spliced at a section or where splices are made at points of maximum stress, special precautions shall be taken, such as increasing the length of lap and/or using spirals or closely spaced stirrups around the length of the splice.

NOTE 1 — The stirrups provided should be able to resist a tension equal to the full tensile force in the lapped bars and should be provided in the outer one-third of the lap length at both ends with at least three stirrups on either side (see Fig. 4.3). In case of thick bars (say $\phi > 28$ mm), lap splices should be completely enclosed by transverse reinforcement, for example, in the form of small compact stirrups or spirals [see Fig. 4.4 (A and B)].

NOTE 2 — Careful detailing is necessary when reinforcements are to be spliced. Therefore location and details of splices should be determined at the design stage itself and indicated in the drawing. Preferably splicing details should not be left to be decided at the site of construction.

4.4.2 Lap Splices

a) *Diameter of bars for lap splicing* — Lap splices shall not be used for bars larger than 36 mm. For larger diameters, bars may be welded (see Appendix A).

In cases where welding is not practicable, lapping of bars larger than 36 mm may be permitted, in which case additional spirals should be provided around the lapped bars (see Fig. 4.4A).

b) *Staggering of lap splices* — Lap splices shall be considered as staggered if the centre-to-centre distance of the splices is not less than 1.3 times the lap length (see Fig. 4.5) calculated as given in (c) below. Bars could be lapped vertically one above the other or horizontally, depending upon the space requirement.

c) *Lap length in tension* — Lap length including anchorage value of hooks in flexural tension shall be L_d or 30ϕ whichever is greater and for direct tension $2 L_d$ or 30ϕ whichever is greater. The straight length of the lap shall not be less than 15ϕ or 200 mm, whichever is greater (see Fig. 4.6).

where

$$L_d = \text{development length}$$

NOTE — Splices in direct tension members shall be enclosed in spirals made of bars not less than 6 mm in diameter with pitch not more than 10 cm. Hooks/bends shall be provided at the end of bars in tension members (see Fig. 4.4C).

d) *Lap length in compression* — The lap length in compression shall be equal to the development length in compression calculated as in 4.2.2 (see Tables 4.2, 4.3 and 4.4), but not less than 24ϕ .

e) *Requirement of splice in a column* — In columns where longitudinal bars are offset at a splice, the slope of the inclined portion of the bar with the axis of the column shall not exceed 1 in 6, and the portions of the

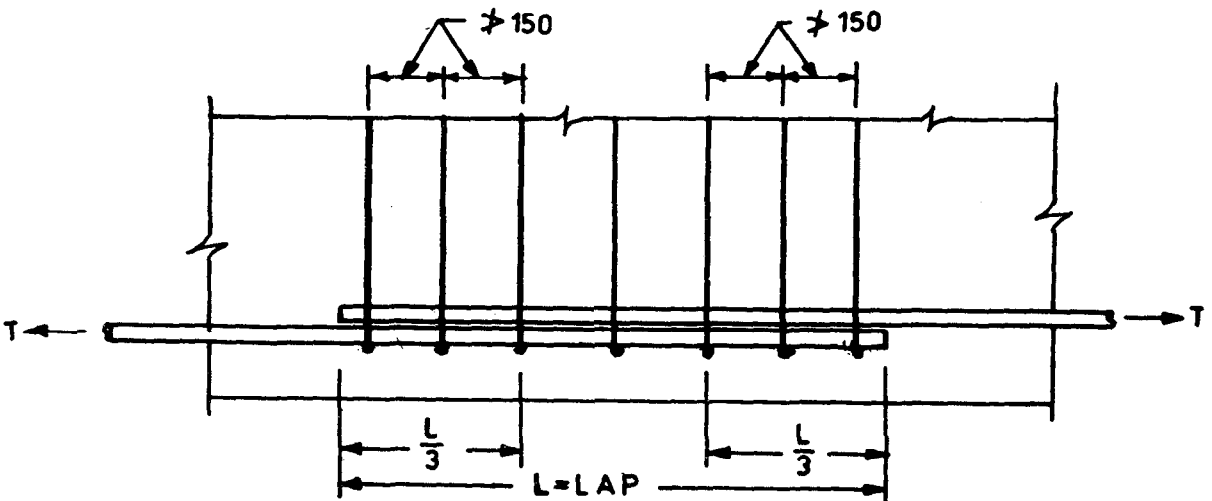

FIG. 4.3 TRANSVERSE REINFORCEMENT AT A SPLICE

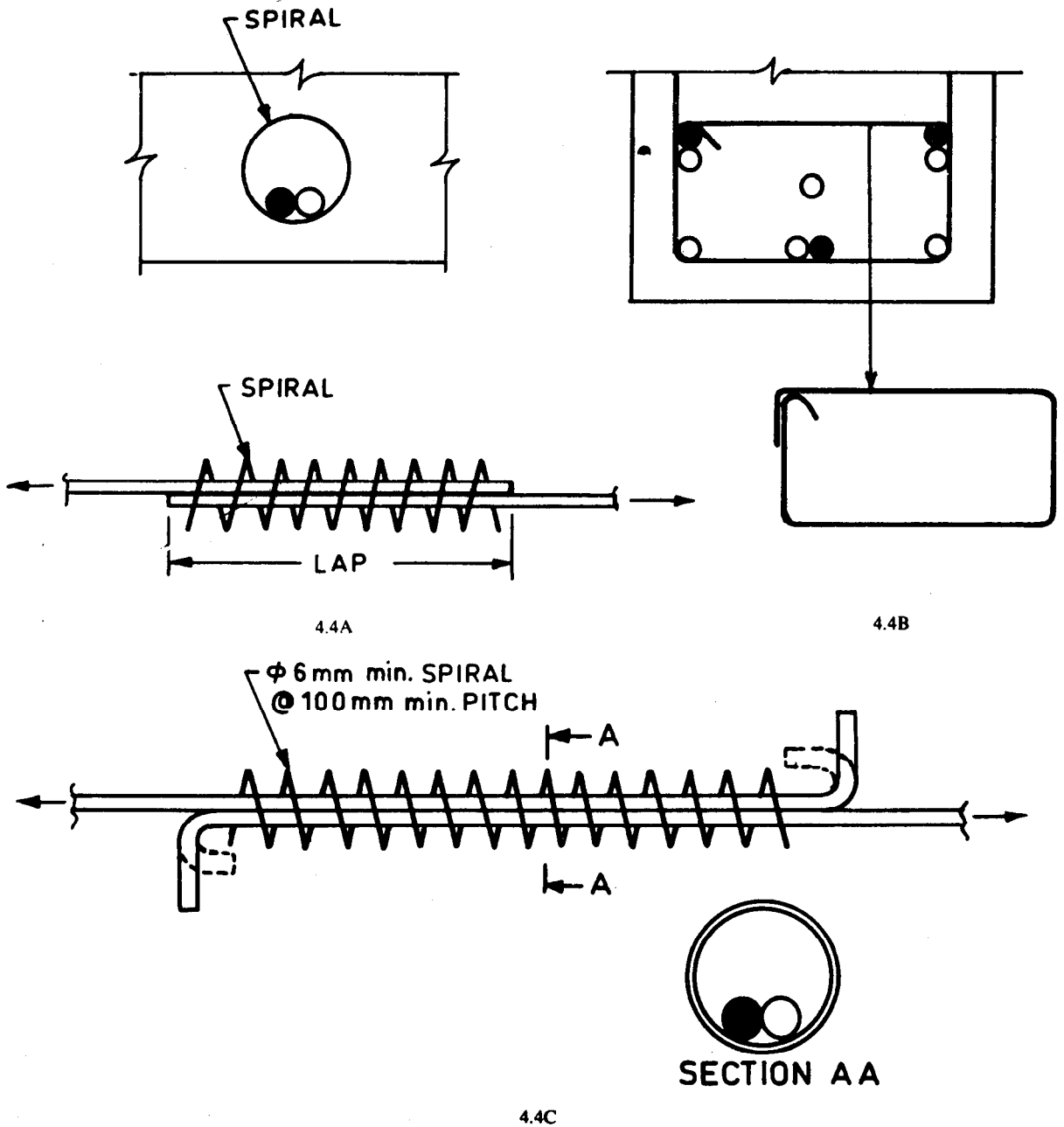

FIG. 4.4 POSSIBLE FORMS OF TRANSVERSE REINFORCEMENT AT A SPLICE

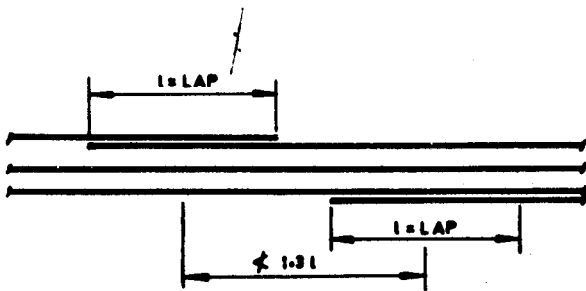
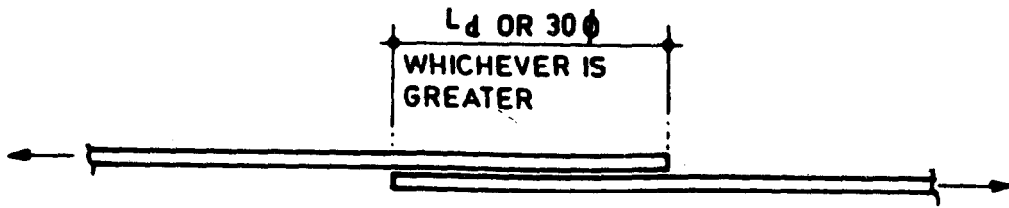
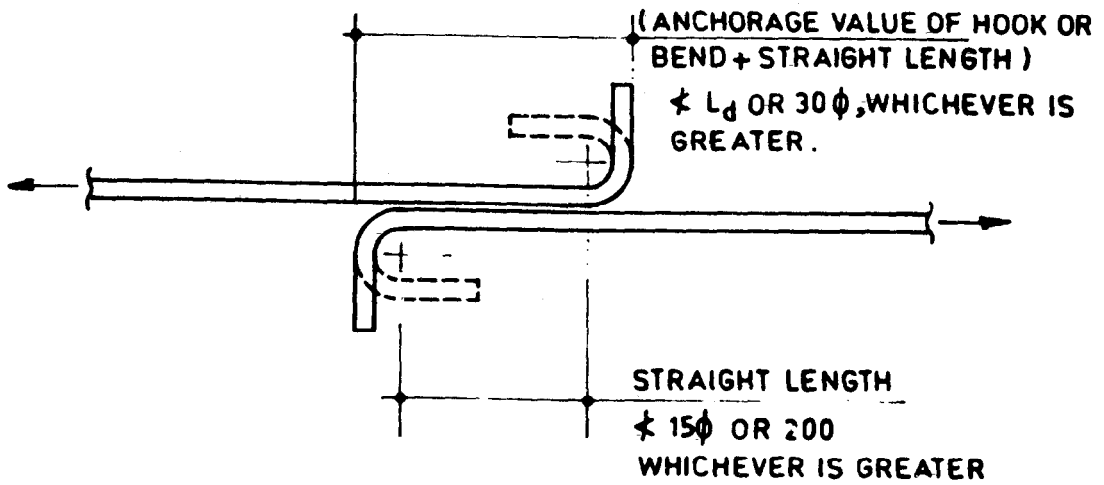

FIG. 4.5 STAGGERING OF LAP SPLICES

bars above and below the offset shall be parallel to the axis of the column. Adequate horizontal support at the offset bends shall be treated as a matter of design, and shall be provided by metal ties, spirals, or parts of the floor construction. Metal ties or spirals so designed shall be placed near (not more than 8ϕ) from the point of bend. The horizontal thrust to be resisted shall be assumed as $1\frac{1}{2}$ times the horizontal component of the nominal force in the inclined



IN FLEXURAL TENSION WITHOUT HOOKS



IN FLEXURAL TENSION WITH HOOKS

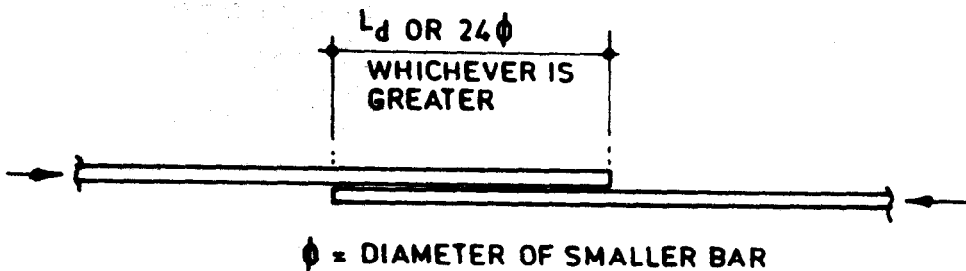

IN COMPRESSION

4.6A BARS IN TENSION AND COMPRESSION

FIG. 4.6 LAP LENGTH (Continued)

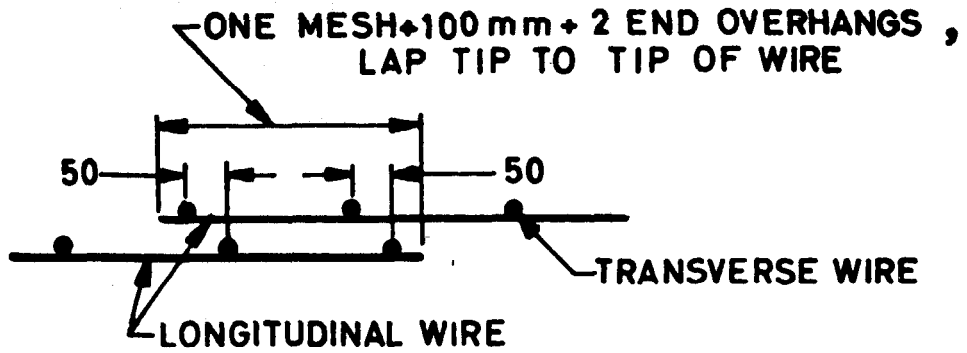

MORE THAN HALF STRESS END AND EDGE LAPS

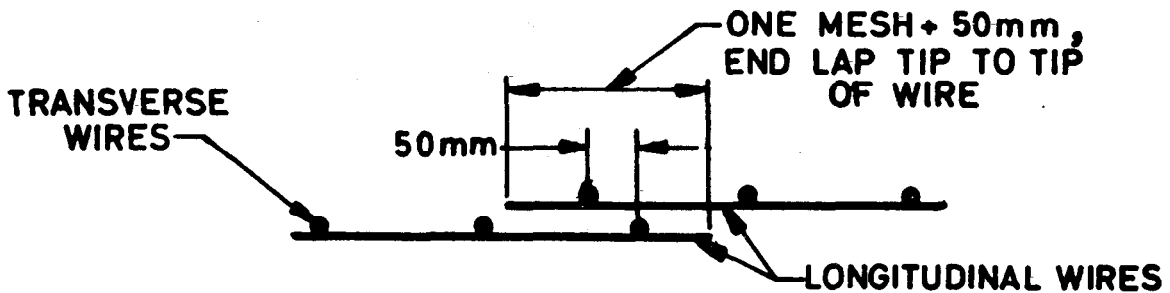

HALF STRESS END LAP

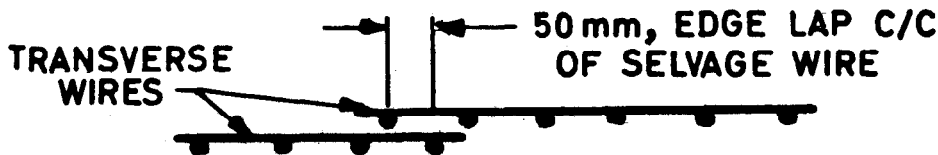

HALF STRESS EDGE LAP

4.6B WELDED WIRE FABRIC

FIG. 4.6 LAP LENGTH

portion of the bar (see Fig. 4.7). Offset bars shall be bent before they are placed in the forms. Where column faces are offset 75 mm or more, splices of vertical bars adjacent to the offset face shall be made by separate dowels overlapped at specified about.

NOTE: It is to be noted that in Fig. 4.7, additional stirrups will be required only near the bottom crank.

f) *Bars of different diameters* — When bars of two different diameters are to be spliced, the lap length shall be calculated on the basis of diameter of the smaller bar.

4.4.2.1 *Lap splices in welded wire fabric*

- a) The fabric is supplied in long mats/rolls and it is rarely necessary to have a joint of the main wires. The rigidly connected cross-members provide mechanical anchorage. Adequate lapping where necessary may be provided with a comparatively short lap when cross wires occur within the lap.
- b) In structural slabs, laps in regions of maximum stress shall be avoided. Such splices, where used for either end or edge laps, shall be made so that the distance between

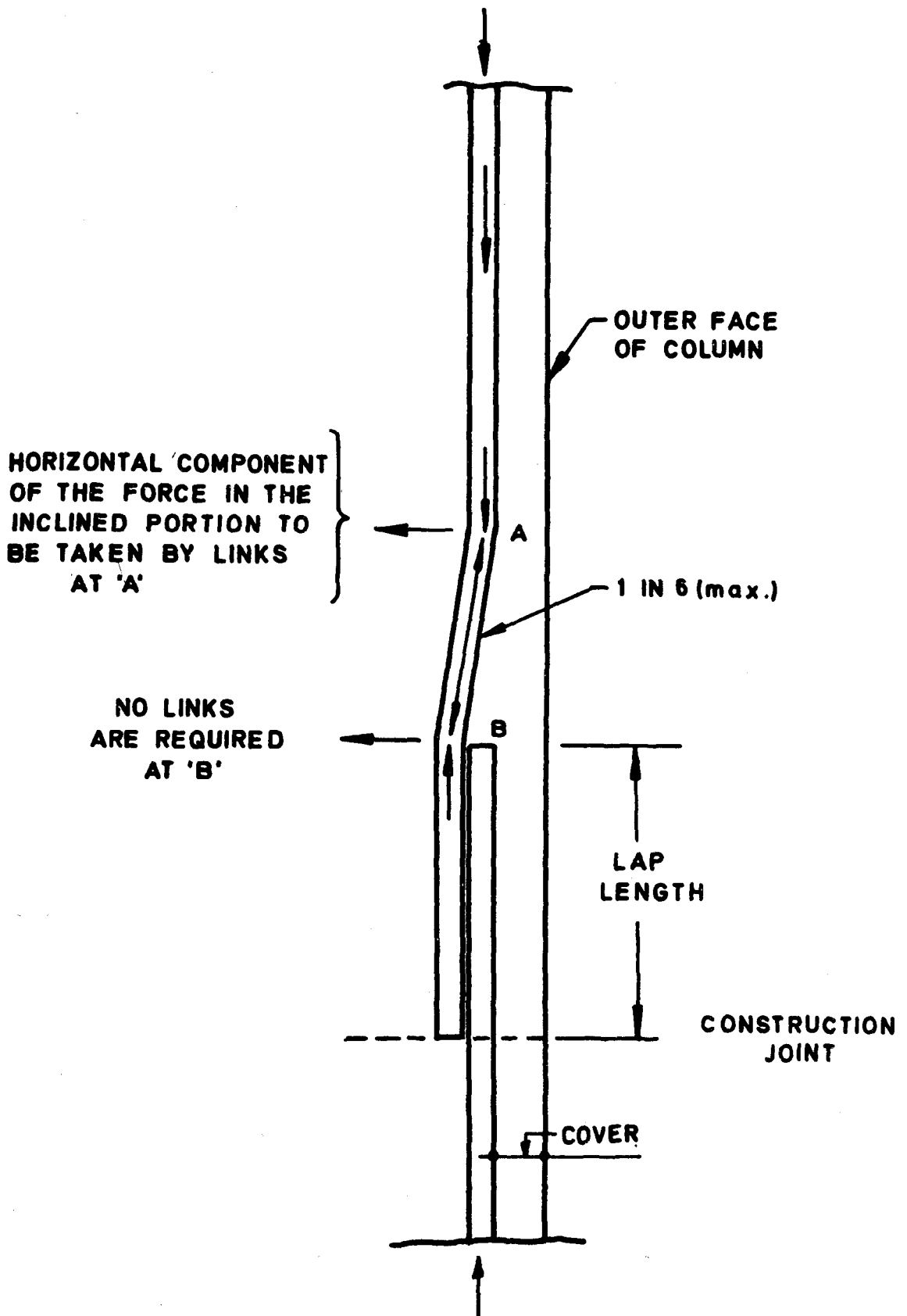

FIG. 4.7 SPLICE WITH OFFSET CRANKED BAR IN A COLUMN

outermost cross wires is not less than the spacing of the wire parallel to the lap plus 100 mm (see Fig. 4.6).

- c) In other cases for end laps, welded wire fabric shall be lapped not less than one mesh plus 50 mm, that is, the length of the lap shall be 50 mm greater than the spacing of wires parallel to the lap. For edge laps, a lap of 50 mm is sufficient (see Fig. 4.6).
- d) These requirements for lapping should be covered by suitable notes in the general specifications. But whether specified by wordings or shown on plans, certain distinction should be made between 'edge laps' and 'end laps'.
- e) The width of an edge lap shall be indicated as the centre-to-centre distance between the outside of longitudinal salvage wires of the overlapping sheets as illustrated in Fig. 4.6.
- f) The length of an end lap shall be indicated as the top-to-top distance between the ends of the longitudinal wires of the overlapping sheets.

4.4.3 Welded Splices and Mechanical Connections — Where the strength of a welded splice or mechanical connection has been proved by tests to be at least as great as that of the parent bar, the design strength of such connections shall be taken as equal to 80 percent of the design strength of the bar for tension splice and 100 percent of the design strength for the compression splice. However, 100 percent of the design strength may be assumed in tension when the spliced area forms not more than 20 percent of the total area of steel at the section and the splices are staggered at least 600 mm centre-to-centre.

The choice of splicing method depends mainly on the cost, the grade of steel, the type of reinforcement, generally high bonding, the possibility of transferring compressive and/or tensile stresses and the available space in the section concerned. The designer shall specify the splicing method and the conditions under which it is to be carried out.

Mechanical coupling devices shall be arranged so that as small a number as possible affect a single section. They should, in addition, be placed outside the most highly stressed sections.

4.4.3.1 Sleeve splicing — If correctly used, sleeve connections may transmit the total compressive or tensile stress. In general, the use of these sleeves is governed by various conditions laid down in the agreement for the method or, in the absence of recommendations, by preliminary testing.

During assembly, particular care shall be taken to ensure that the lengths introduced into the sleeve are sufficient.

These lengths should be marked before hand on the ends of the bars to be spliced except when a visual check on penetration is possible (for example, sleeve with a central sight hole):

- a) *Threaded couplers* (see Fig. 4.8) — In order to prevent any decrease in the end sections of the bar as a result of threading (with V-form or round threads), they can be:

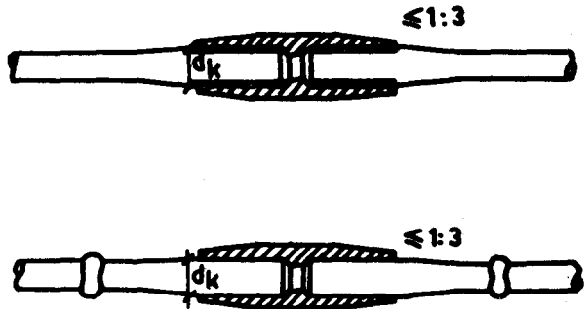

FIG. 4.8 THREADED COUPLERS (THREADING LIMITED TO THE ENDS OF BARS)

- 1) upset;
- 2) for long units, fitted with larger section threaded ends by flash welding; or
- 3) fitted with a threaded sleeve by crimping.

Another solution consists of threading the ends but only taking into consideration the nominal section of the threaded end, that is, reducing the permissible stress in the reinforcement.

The ends of the sleeve shall be slightly reduced in section in order to prevent overstressing of the first few threads.

There are, at present, reinforcing bars with oblique, discontinuous, spiral ribs, allowing splicing with a special sleeve with internal threads.

This same process is used to splice prestressing bars, and in order to prevent confusion between reinforcing bars and prestressing steels, the direction of threading is reversed (see Fig. 4.9).



FIG. 4.9 COUPLER FOR REINFORCING BARS ($\phi 20$ TO $\phi 28$)

Two lock nuts, tightened on each side of the sleeve into which the reinforcing bars are introduced to the same depth, prevent any accidental unscrewing due to slack in the threads (splices not under tension). The nuts are tightened with a torque wrench.

This device is also used for splicing prefabricated elements.

These joints are generally 100 percent efficient under both tension and compression.

To decrease the *in-situ* operations, one of the ends is generally fitted with its sleeve in advance and the other bar to be joined with the sleeve should remain manoeuvrable until the splice has been made (see Fig. 4.10).

- b) *Coupling with a crimped sleeve* — Crimped sleeves constitute a method of splicing limited to relatively large diameter deformed reinforcing bars. It consists of the introduction of the bars to be spliced into a sleeve which is crimped by means of a hydraulic crimping tool onto the ribbed bars in order to fill the voids between them and the inner surface of the sleeve. The ribs on the bar penetrate into the relatively softer steel of the sleeve and the ribs work in shear.

During crimping the sleeve lengthens, and the other reinforcing bar to be spliced should be displaceable at this moment. The size of the crimping device requires a bar interspacing of at least 10 cm (see Fig. 4.11).

Splicing by crimping is also possible with reinforcing bars of differing diameter. The same method also enables threaded steel rods to be spliced to reinforcing bars, using high strength threaded bolts (see Fig. 4.12).

- c) *Coupling with injected sleeves* — These couplings are a special case of sleeve splicing; the stresses are distributed by the shear strength of the product injected between the ends of the bars to be sleeve spliced:

- 1) With the 'Thermit' sleeve the space between the deformed bars and the sleeve, whose internal surface is also ribbed, is filled with a special molten metal. This molten metal is prepared in a crucible, which is in communication with the sleeve, by igniting a mixture consisting mainly of iron oxide and aluminium powder. The strength of the sleeve may be increased by using a larger sleeve diameter (see Fig. 4.13).

The sleeve is shorter but wider than that used in the crimping method. The bars are not in contact.

The splice may be made in any direction as long as space allows the crucible to be put into place.

- 2) Similar method is the injection of grout or an epoxy resin between the sleeve and the bars. The length of the sleeve is necessarily greater (see Fig. 4.14).
- d) *Butt splices* — For this purpose open flanged sleeves made from steel strip can be used. They are tightened onto the bars by the introduction of a flat tapered wedge (see Fig. 4.15).

The end sections, in contact within the device, shall be perfectly at right angles to the axis of the spliced bars.

Another method involves the use of 4 small diameter ribbed bars which are tightened, using pliers, with 3 ring-clamps. The advantage of this method, in comparison to the previous one, is the fact that it allows a portion of the tensile stress to be taken up.

For bars with ribs in the form of a thread, a butt splice may be made with a sleeve, but with greater facility.

There are also sleeves consisting of a metallic cylinder, the internal diameter of which fits the bars to be spliced. This sleeve is fixed to one of the reinforcing bars by a few welding points: a hole at the centre of the sleeve enables one to check that there is contact between the bars. This

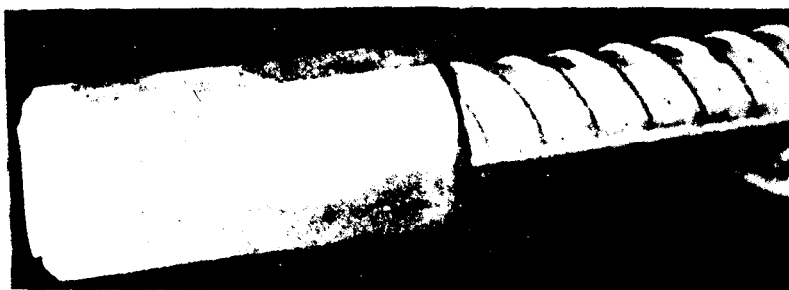

FIG. 4.10 SPLICING WITH THREADED COUPLERS



FIG. 4.11 CRIMPED SLEEVES

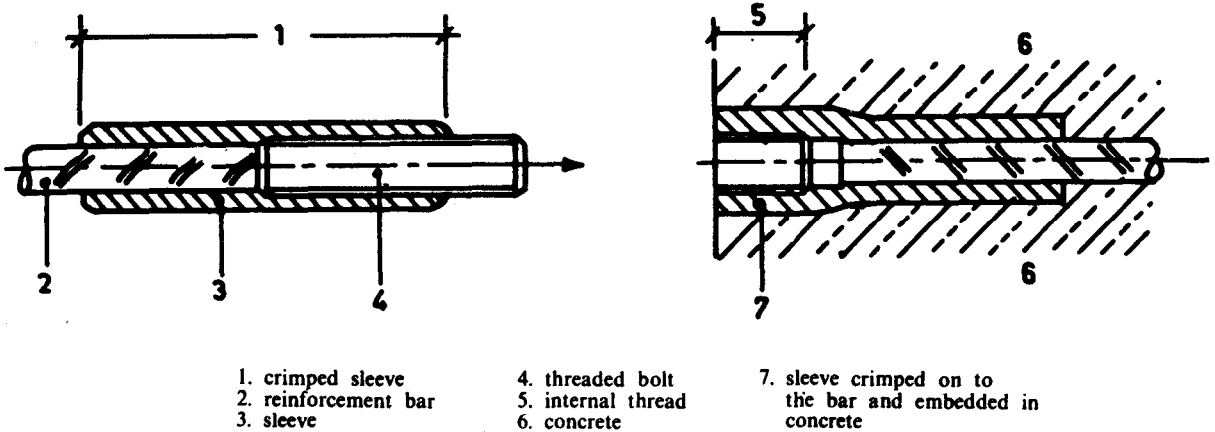

FIG. 4.12 SLEEVE CRIMPED ON TO A THREADED ROD

- 1. crimped sleeve
- 2. reinforcement bar
- 3. sleeve
- 4. threaded bolt
- 5. internal thread
- 6. concrete
- 7. sleeve crimped on to the bar and embedded in concrete

economical method of splicing, which is easy to apply, can only transmit compressive stresses.

4.4.3.2 Main advantages and disadvantages of mechanical coupling

- a) The use of mechanical couplers is frequently justified when space does not allow lapping, although crimping and tightening tools require accessibility which may reduce this advantage.
- b) This splicing method often requires more careful cutting of the reinforcing bar, a check which is more difficult than in the case of lapping; it also requires the use of reinforcing bars of the same diameter, and mobility of one of the two bars to be spliced.
- c) Good performance of the splice is not endangered by special atmospheric conditions as in welding.
- d) The cost of equipment and its use limit this method to exceptional cases only.

NOTE — Some mechanical methods of splicing of reinforcement which are in vogue in this country make use of the following principles:

- a) A special grade steel sleeve is swaged on to reinforcing bars to be joined with the help of a portable hydraulically operated bar grip press either at site or at stocking yard.

- b) Two sleeves with threaded ends are drawn together by an interconnecting stud. These sleeves are then swayed on to the reinforcing bars either at site or at the stocking yard.

4.4.3.3 Welded splices (or joints)— The details of welding mild steel bars and cold-worked steel bars in accordance with IS : 2751-1979 'Code of practice for welding of mild steel plain and deformed bars for reinforced concrete construction (first revision)' and IS : 9417-1979 'Recommendations for welding cold-worked steel bars for reinforced concrete construction' respectively are covered in Appendix A.

4.5 Hooks and Bends

4.5.1 Hooks and bends, and other anchorage of reinforcement in reinforced concrete shall be of such form, dimensions and arrangement as will ensure their adequacy without over-stressing the concrete or steel.

4.5.2 Where normal hooks are used, they should be of U-type or L-type; but usually U-type is preferred for mild steel bars and L-type for deformed bars. If the radius of the bend or hooks conforms to that of the standard hooks or bends in longitudinal bars, the bearing stresses inside the bend in concrete need not be checked (see 4.5.2.1 and 4.5.2.2).

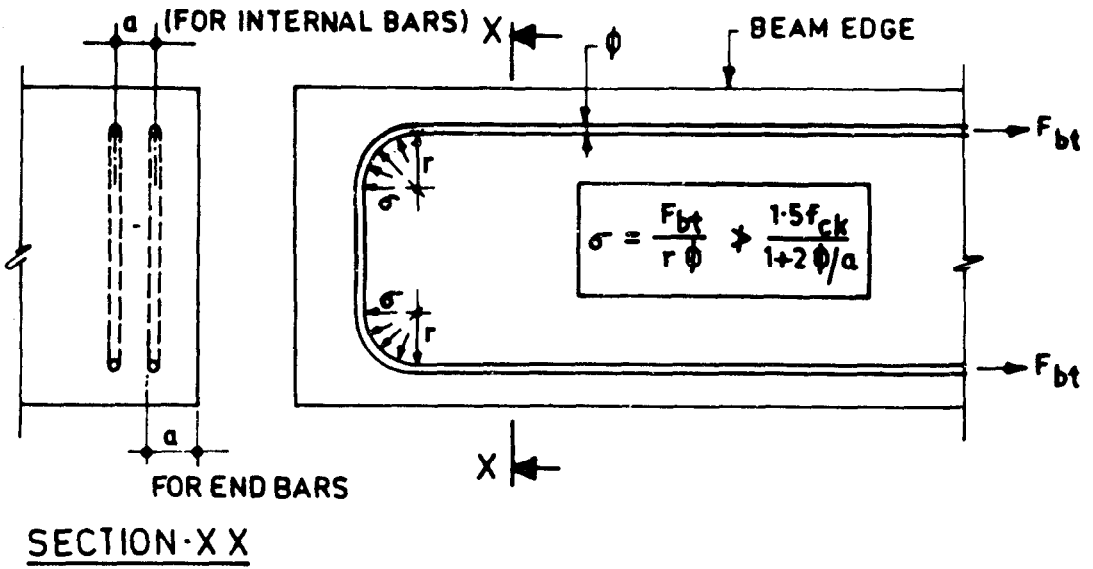

4.16A BEARING STRESS AT BENDS

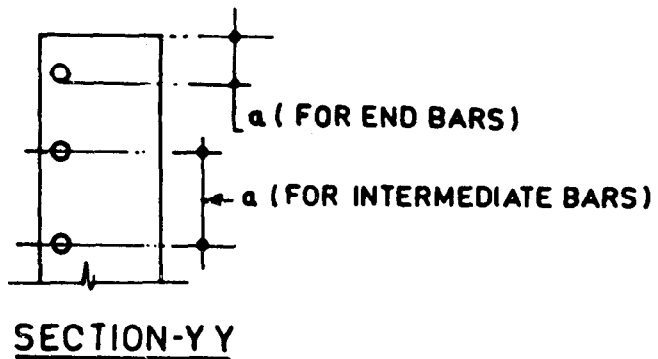
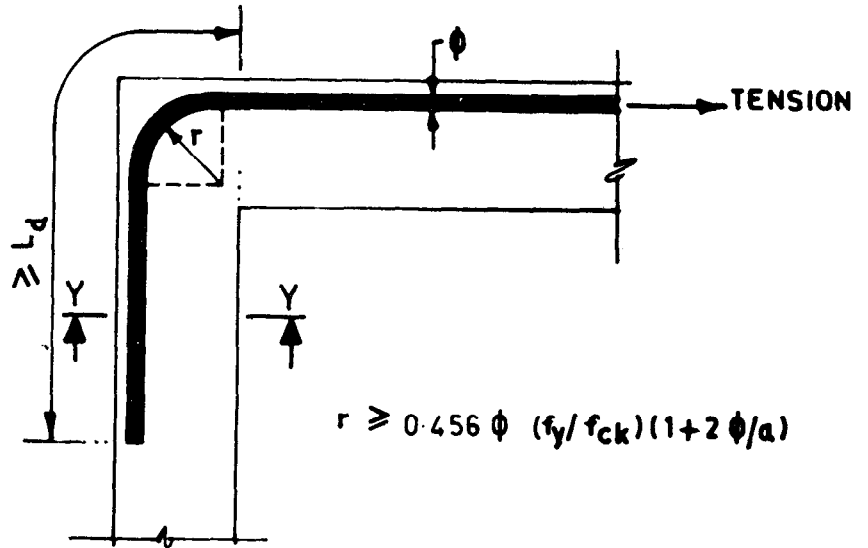

4.16B MINIMUM INTERNAL RADIUS OF BEND FOR EFFECTIVE ANCHORAGE OF FULLY STRESSED TENSION BARS

FIG. 4.16 BEARING STRESS AT INTERNAL BENDS

stress in concrete for standard hooks and bends described in Table 4.1.

$$\text{Bearing stress, } \sigma = \frac{F_{bt}}{r \phi}$$

where

F_{bt} = tensile force due to design loads in a bar or group of bars (N);

r = internal radius of the bend (mm); and

ϕ = size of the bar or, if in bundle, the size of bar of equivalent area (mm).

For limit state method of design, this stress

shall not exceed $\frac{1.5 f_{ck}}{1 + \frac{2\phi}{a}}$, where f_{ck} is the

characteristic strength of concrete and a , for a particular bar or group of bars in contact shall be taken as a centre-to-centre distance between bars or groups of bars perpendicular to the plane of the bend (mm); for a bar or group of bars

adjacent to the face of the member, a shall be taken as the cover plus size of bar.

In other words, the minimum radius of the bend, r , should be such that

$$r \geq 0.456 \phi \left(\frac{f_y}{f_{ck}} \right) \left(1 + \frac{2\phi}{a} \right)$$

When the large steel stresses need to be developed in the bend, radial bearing stresses in the concrete may become excessive. The above equation controls the diameter of bend when there is a combination of high tensile stress in the bend, large bar diameter and low concrete strength. To simplify the application of the above formula minimum radius of bend is given in Table 4.5 for different grades of concrete and steel.

4.5.2.2 If a change in direction of tension or compression reinforcement induces a resultant force acting outward tending to split the concrete, such force should be taken up by additional links

TABLE 4.5 MINIMUM RADIUS OF BEND FOR BARS FULLY STRESSED AT BENDS IN cm

(Clause 4.5.2.1)

| f_y N/mm ² | f_{ck} N/mm ² | a cm | DIAMETER OF BAR IN mm | | | | | |
|----------------------------|-------------------------------|-----------|-----------------------|------|------|------|-------|-------|
| | | | 10 | 12 | 16 | 20 | 25 | 32 |
| (1) | (2) | (3) | (4) | (5) | (6) | (7) | (8) | (9) |
| 250 | 15 | 2.5 | 13.7 | 17.9 | 27.7 | 39.5 | 57.0 | 86.6 |
| | | 5.0 | 10.6 | 13.5 | 19.9 | 27.4 | 38.0 | 55.4 |
| | | 7.5 | 9.6 | 12.0 | 17.3 | 23.3 | 31.7 | 45.1 |
| | | 10.0 | 9.1 | 11.3 | 16.1 | 21.3 | 28.5 | 39.9 |
| | | 15.0 | 8.6 | 10.6 | 14.8 | 19.3 | 25.3 | 34.7 |
| | 20 | 2.5 | 10.3 | 13.4 | 20.8 | 29.6 | 42.8 | 65.0 |
| | | 5.0 | 8.0 | 10.1 | 14.9 | 20.6 | 28.5 | 41.6 |
| | | 7.5 | 7.2 | 9.0 | 13.0 | 17.5 | 23.8 | 33.8 |
| | | 10.0 | 6.8 | 8.5 | 12.1 | 16.0 | 21.4 | 29.9 |
| | | 15.0 | 6.5 | 8.0 | 11.1 | 14.7 | 19.0 | 26.0 |
| 415 | 15 | 2.5 | 22.7 | 29.7 | 46.0 | 65.0 | 94.6 | 143.7 |
| | | 5.0 | 17.7 | 22.4 | 33.1 | 45.4 | 50.5 | 92.0 |
| | | 7.5 | 16.0 | 20.0 | 28.8 | 38.7 | 52.6 | 74.8 |
| | | 10.0 | 15.1 | 18.8 | 26.6 | 35.3 | 47.3 | 66.2 |
| | | 15.0 | 14.3 | 17.6 | 24.5 | 32.0 | 42.1 | 57.6 |
| | 20 | 2.5 | 17.0 | 22.3 | 34.5 | 48.8 | 71.0 | 107.8 |
| | | 5.0 | 13.3 | 16.8 | 24.8 | 34.1 | 37.9 | 69.0 |
| | | 7.5 | 12.0 | 15.0 | 21.6 | 29.0 | 39.5 | 56.1 |
| | | 10.0 | 11.3 | 14.1 | 20.0 | 26.5 | 35.5 | 49.7 |
| | | 15.0 | 10.7 | 13.2 | 18.4 | 24.0 | 31.6 | 43.2 |
| 500 | 15 | 2.5 | 27.4 | 35.8 | 55.5 | 79.0 | 114.0 | 173.2 |
| | | 5.0 | 21.3 | 27.0 | 39.9 | 54.7 | 76.0 | 110.9 |
| | | 7.5 | 19.3 | 24.1 | 34.7 | 46.6 | 63.3 | 90.2 |
| | | 10.0 | 18.2 | 22.6 | 32.1 | 42.6 | 57.0 | 79.8 |
| | | 15.0 | 17.2 | 21.2 | 29.5 | 38.5 | 50.7 | 69.4 |
| | 20 | 2.5 | 20.6 | 26.9 | 41.6 | 59.3 | 85.5 | 130.0 |
| | | 5.0 | 16.0 | 20.3 | 29.9 | 41.0 | 57.0 | 83.2 |
| | | 7.5 | 14.5 | 18.1 | 26.0 | 35.0 | 47.5 | 67.7 |
| | | 10.0 | 13.7 | 17.0 | 24.1 | 32.0 | 42.8 | 59.9 |
| | | 15.0 | 12.9 | 15.9 | 22.1 | 28.9 | 38.0 | 52.0 |

NOTE—The minimum radius is based on the full design stress in steel at the bend. In the absence of more precise calculations, it may be assumed that the tensile stress due to the anchorage at the source of a hook is equal to half the stress on the bar, by reasons of its mechanical strength.

or stirrups. Accordingly in structural components with curved or angled soffits, or those formed with bends or corners, it should be ensured that the radial tensile forces due to changes in the direction of reinforcement are resisted by additional links (see Fig. 4.17). Bent tension bar at a re-entrant angle should be avoided.

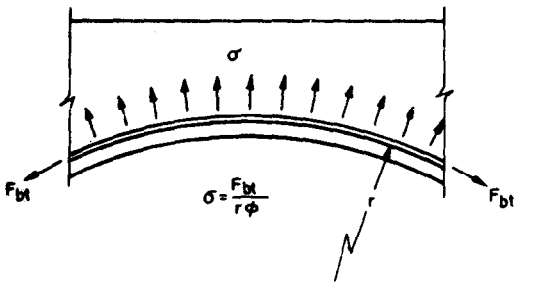

4.17A TENSION BAR IN A CURVED SOFFIT

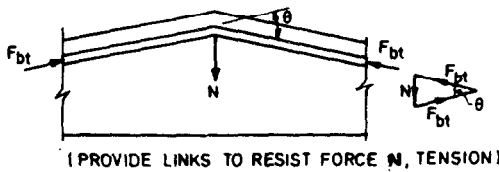

4.17B COMPRESSION BAR IN HOGGING BEAM

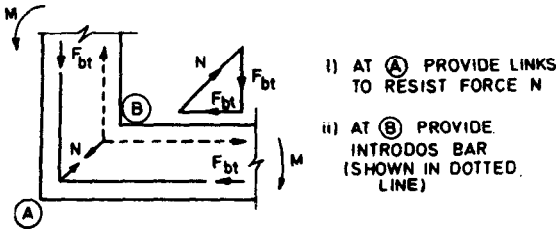

4.17C COMPRESSION BAR IN A CORNER

FIG. 4.17 RADIAL FORCES IN REINFORCEMENT

4.5.2.3 The minimum straight length of hook is four times the bar diameter. For small diameter bars this should be a minimum of 50 mm in order to facilitate holding the bar in place while forming the hook. The hooks when formed are quite large and while detailing it is important to ensure that they do not foul with other reinforcement, particularly where beams have more than one row of bars.

4.5.2.4 Reinforcing bars shall be so detailed that the hooks are not positioned in tensile zones of concrete as this may cause cracking. It is better to bend the bars so that the hooks and bars terminate in compression zones or so lengthen the bars to eliminate the need for hooks.

4.6 Curtailment of Tension Reinforcement in Flexural Members

4.6.1 For curtailment, reinforcement shall extend beyond the point at which it is no longer required to resist flexure for a distance equal to the effective depth of the member or 12 times the

bar diameter, whichever is greater, except at simple support or end of cantilever. Figures 4.18 to 4.21 illustrate the requirement at cut-off point and at supports in flexural members.

NOTE 1 — A point at which reinforcement is no longer required to resist flexure is where the resistance moment of the section, considering only the continuing bars, is equal to the design moment.

NOTE 2 — The points at which reinforcement can be curtailed is to be based on the bending moment envelope developed by the designer. It should be noted that the use of envelope helps in achieving better design. A typical bending moment envelope considering various loading conditions is given in Fig. 4.22.

Figure 4.23 gives a standard bending moment diagram (based on uniformly distributed load) to enable designers to choose locations for curtailment of reinforcement. In any case the curtailment of reinforcement should fulfill the requirements given in 4.6.1 to 4.6.4.

4.6.2 Flexural reinforcement shall not, preferably, be terminated in a tension zone unless any one of the following conditions is satisfied (see Fig. 4.18):

- a) The shear at the cut-off point does not exceed two-thirds that permitted, including the shear strength of web reinforcement provided.
- b) Stirrup area in excess of that required for shear and torsion is provided along each terminated bar over a distance from the cut-off point equal to three-fourths the effective depth of the member. The excess stirrup area (mm²) shall be not less than 0.4 b s / f_y, where b is the breadth of beam (mm), s is the spacing (mm) and f_y is the characteristic strength of reinforcement (N/mm²). The resulting spacing shall not exceed (d/8) β_s where β_s is the ratio of the area of bars cut-off to the total area of bars at the section and d is the effective depth.
- c) For 36 mm and smaller bars, the continuing bars provide double the area required for flexure at the cut-off point and the shear does not exceed three-fourths that permitted.

4.6.3 Positive Moment Reinforcement

- a) At least one-third the maximum positive moment reinforcement in simple members and one-fourth the maximum positive moment reinforcement in continuous members shall extend along the same face of the member into the support, to a length equal to L_d/3 (see Fig. 4.18), where L_d is the development length based on fully stressed bars. This is required to provide for some shifting of the moment due to changes in the loading, settlement of supports, lateral loads and other causes.
- b) When a flexural member is part of a primary lateral load resisting system, the positive reinforcement required to be extended into the support according to (a) shall be anchored to develop its design

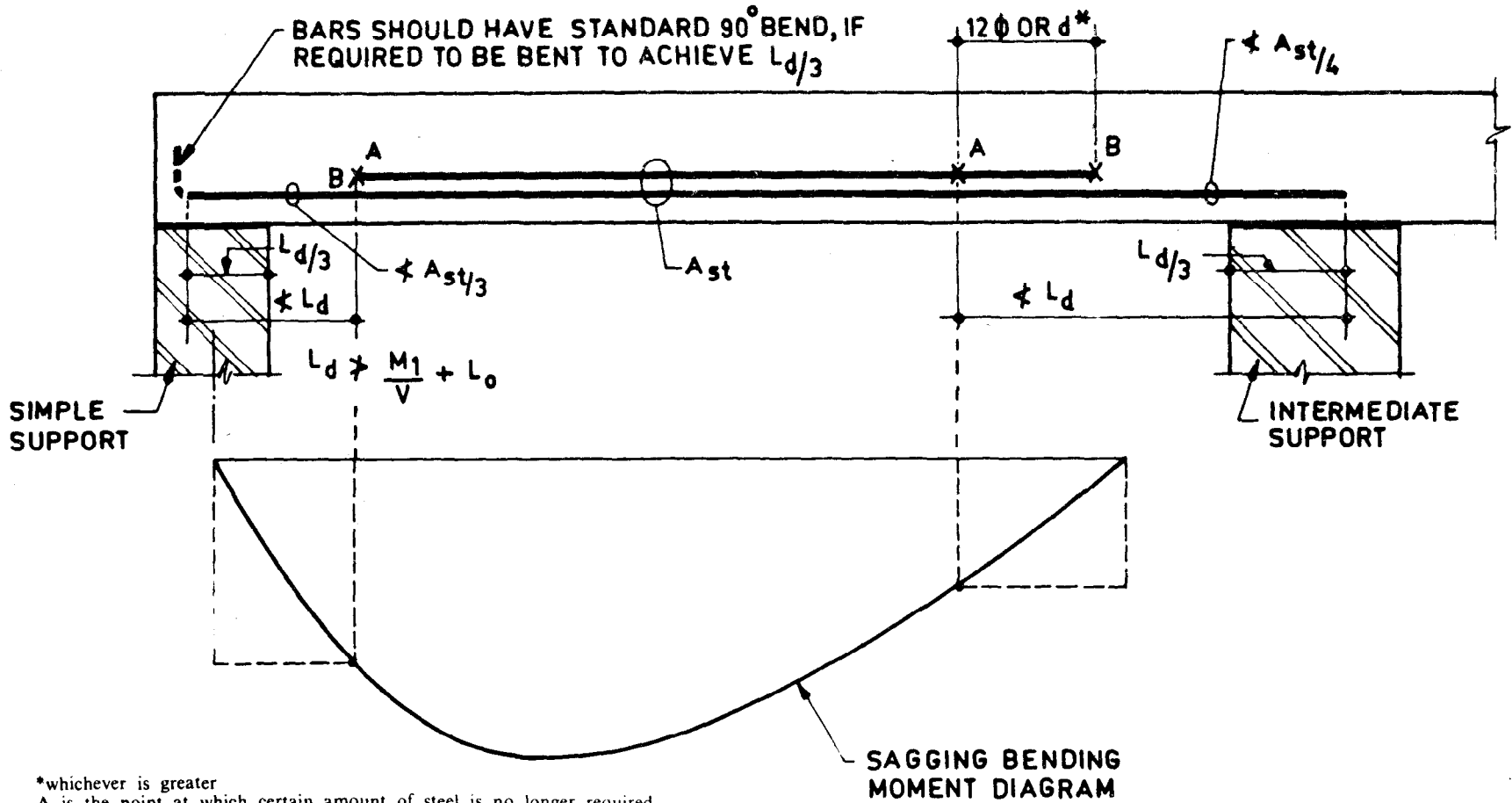

*whichever is greater

A is the point at which certain amount of steel is no longer required
Any one of the conditions to be satisfied at the actual cut-off point, B:

i) For bars $< \phi 36$, $A_1 \geq 2A_2$ and $V_s \geq \frac{3}{4}V$

ii) Excess stirrup area (than that is required from design) in a distance of $\frac{3}{4}d$ from the cut-off point along the terminated bar $< \frac{0.4bs}{f_s}$ with spacing $> \frac{d}{8}B_s$

iii) $V_s \geq \frac{2}{3}V$

Notations:

- A_n = positive moment steel as per actual design
- L_d = development length based on fully stressed bars
- V_s = shear at the cut-off point
- V = shear strength of the section
- A_1 = the critical area of steel required at the cut-off point
- A_2 = area of continuing steel
- S = spacing of stirrups without cutting of steel
- b = breadth of member
- d = effective depth
- f_s = characteristic strength of reinforcement
- $B_s = \frac{\text{area of bars cut-off}}{\text{Total area}}$

FIG. 4.18 TENSILE DEVELOPMENT LENGTHS FOR POSITIVE MOMENT STEEL IN SLAB/BEAM WITH ONE SIDE CONTINUOUS AND THE OTHER DISCONTINUOUS

stress (fully developed stress) in tension at the face of the support (see Fig. 4.19). This anchorage is to assure ductility of response in the event of unexpected over-stress such as from an earthquake. It is not sufficient to use more reinforcement at lower stresses. The full anchorage requirement does not apply to any excess reinforcement over and above that provided at the support.

- c) At simple supports and at points of inflection, positive moment tension reinforcement shall be limited to a diameter such that L_d does not exceed (see Fig. 4.18)

$$\frac{M_1}{V} + L_o$$

where

M_1 = moment of resistance of the section assuming all reinforcement at the section to be stressed to f_d ;

$f_d = 0.87 f_y$ in the case of limit state design;

V = shear force at the section; and

L_o = sum of the anchorage beyond the centre of the support and the equivalent anchorage value of any hook or mechanical anchorage at simple support; and at a point of inflection, L_o is limited to the effective depth of the members or 12ϕ , whichever is greater.

The value of M_1/V in the above expression may be increased by 30 percent when the ends of the reinforcement are confined by a compressive reaction. In routine design calculations, it may be

found that $\frac{M_1}{V} > L_d$, and hence no further check need be made. When the requirement

$$L_d \geq \frac{M_1}{V} + L_o$$

is not satisfied, the designer should either reduce the diameter of bars, whereby L_d is reduced, or

increase the area of positive reinforcement at the section considered, whereby M_1 is increased, or resort to both the steps.

4.6.4 Negative Moment Reinforcement — At least one-third of the total tension reinforcement provided for negative moment at the support shall extend beyond the point of inflection (PI) not less than the effective depth of the member or 12ϕ or one-sixteenth of the clear span, whichever is greater (see Fig. 4.20 and 4.21).

4.7 Spacing of Reinforcement — For the purpose of this clause, the diameter of a round bar shall be its nominal diameter, and in the case of bars which are not round or in the case of deformed bars or crimped bars, the diameter shall be taken as the diameter of a circle giving an equivalent effective area. Where spacing limitations and minimum concrete cover are based on bar diameter, a group of bars bundled in contact shall be treated as a single bar of diameter derived from the total equivalent area.

4.8 Bars Bundled in Contact

4.8.1 General — Bars in pairs, or in groups of 3 or 4 tied together and in contact side by side (bundled bars) may be used in beams and columns. This has been the practice in USA for many years, and is now permitted in most countries including India.

As bundled bars provide more reinforcement in less space than do single bars, it is possible to reinforce a member more heavily and still get better compaction of concrete. Beam and column sizes can thus often be reduced with saving in cost.

Bundled bars shall not be used in members without stirrups. Bundled bars shall be tied together to ensure the bars remain together as a bundle. Bars larger than 36 mm diameter shall not be bundled except in columns.

Whenever bar spacing limitations, minimum cover, tie size and spacing are based on bar diameter, a group of bars bundled in contact shall

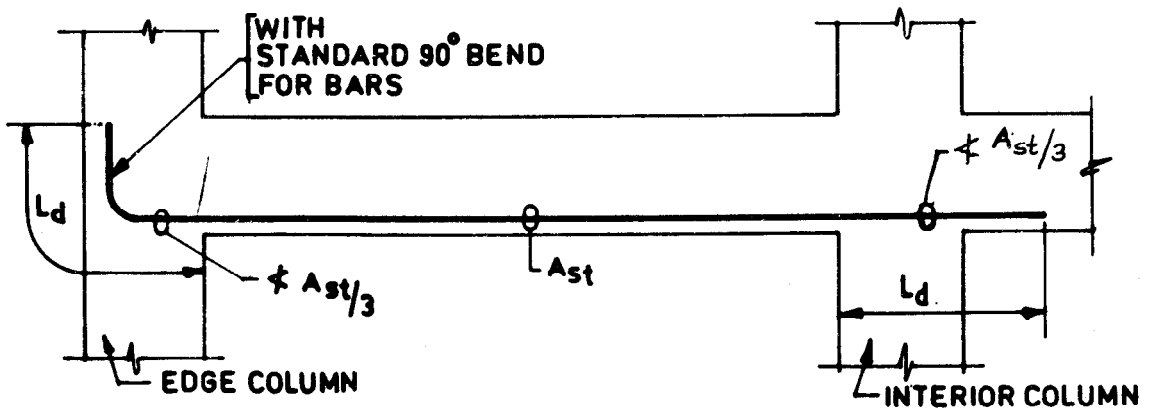

L_d is development length based on fully stressed bars.

FIG. 4.19 TENSILE ANCHORAGE OF POSITIVE MOMENT STEEL IN BEAMS (WHEN BEAMS ARE PART OF A LATERAL LOAD RESISTING SYSTEM)

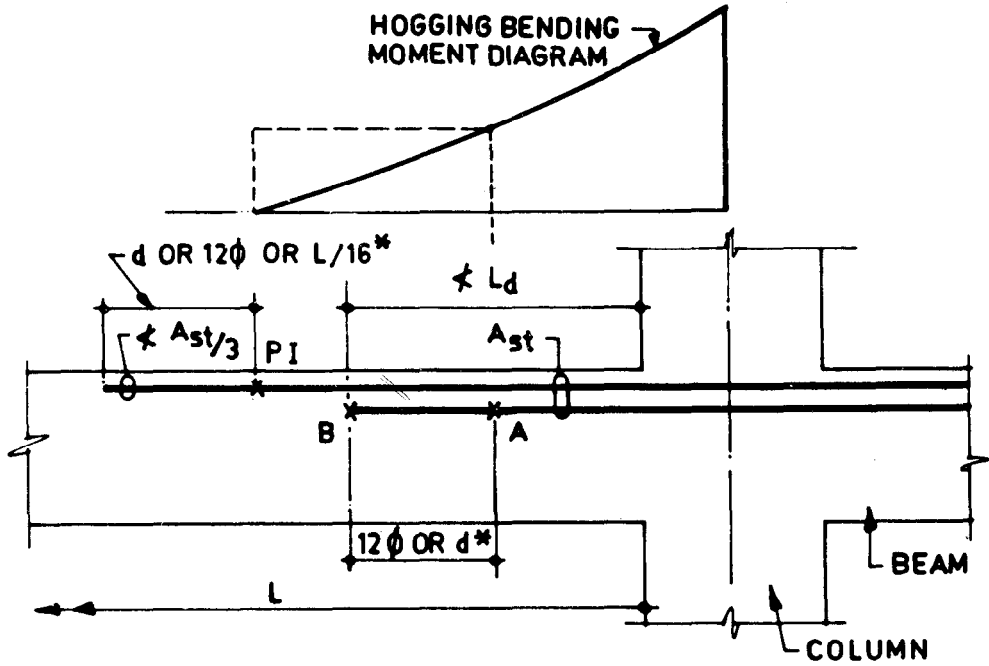

*whichever is greater
 A is theoretical cut-off point at which certain amount of reinforcement is no longer required
 B is actual cut-off point
 PI is point of inflection

FIG. 4.20 TENSILE DEVELOPMENT LENGTH FOR NEGATIVE MOMENT AT CONTINUOUS EDGE

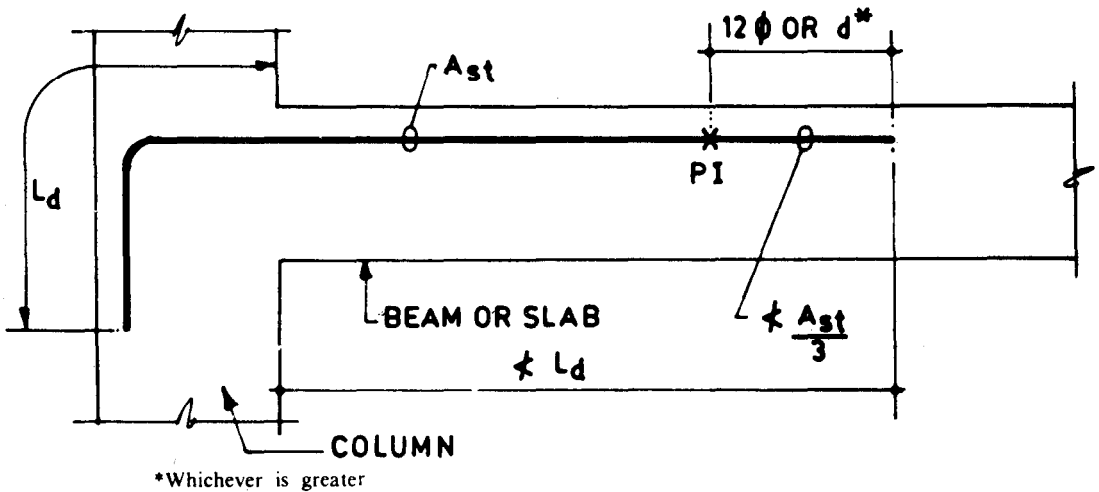

*Whichever is greater

FIG. 4.21 TENSILE DEVELOPMENT LENGTHS FOR POSITIVE MOMENT STEEL AT DISCONTINUOUS ENDS

be treated as a single bar of diameter derived from the total equivalent area (see Table 4.6). However, the cover provided should be measured from the actual outside contour of the bundle.

NOTE 1 — Unless patented splices are used, the bundling of bars in columns is not recommended, as all joints have to be staggered. However, even when patented splices are used the necessary staggering of splices makes assembly difficult and prefabrication cumbersome.

NOTE 2 — It is recommended to limit the bundle only to two bars or three bars as four bars many times do not tie into a stable bundle.

4.8.2 *Development Length* — L_d of each bar of bundled bars shall be that for the individual bar, increased by 10 percent for two bars in contact, 20 percent for three bars in contact and 33 percent for four bars in contact. The

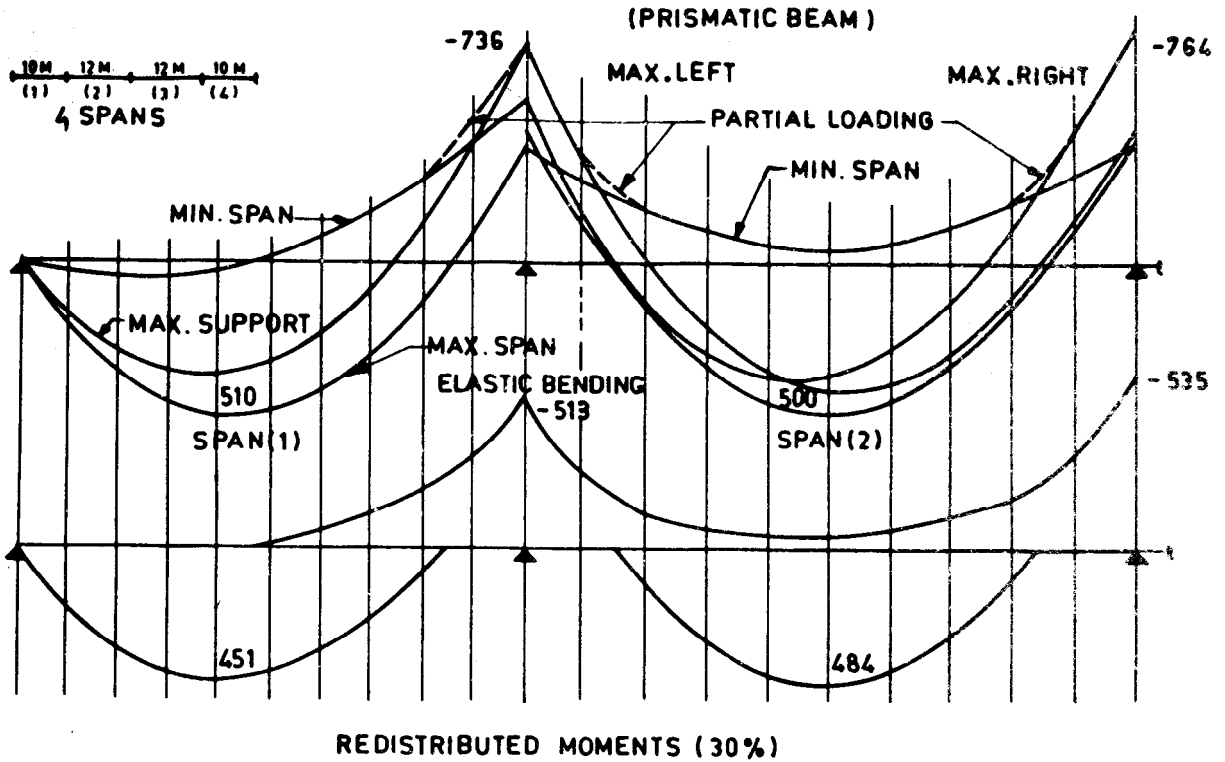

FIG. 4.22 A TYPICAL BENDING MOMENT ENVELOPE

TABLE 4.6 EQUIVALENT BAR SIZE FOR BARS IN GROUPS

(Clause 4.8.1)

| BAR SIZE (ϕ) | BUNDLED BARS | | | | | |
|------------------------|-----------------|-----------------|-----------------|-----------------|-----------------|-----------------|
| | 2 BARS | | 3 BARS | | 4 BARS | |
| | Area | Equivalent Size | Area | Equivalent size | Area | Equivalent size |
| (1) | (2) | (3) | (4) | (5) | (6) | (7) |
| mm | mm ² | mm | mm ² | mm | mm ² | mm |
| 10 | 157 | 14 | 236 | 17 | 314 | 20 |
| 12 | 226 | 17 | 339 | 21 | 453 | 24 |
| 16 | 402 | 23 | 603 | 28 | 804 | 32 |
| 18 | 509 | 25 | 763 | 31 | 1 017 | 36 |
| 20 | 628 | 28 | 942 | 35 | 1 257 | 40 |
| 22 | 760 | 31 | 1 140 | 38 | 1 520 | 44 |
| 25 | 982 | 35 | 1 473 | 43 | 1 963 | 50 |
| 28 | 1 231 | 40 | 1 847 | 50 | 2 463 | 56 |
| 32 | 1 608 | 45 | 2 412 | 55 | 3 216 | 64 |

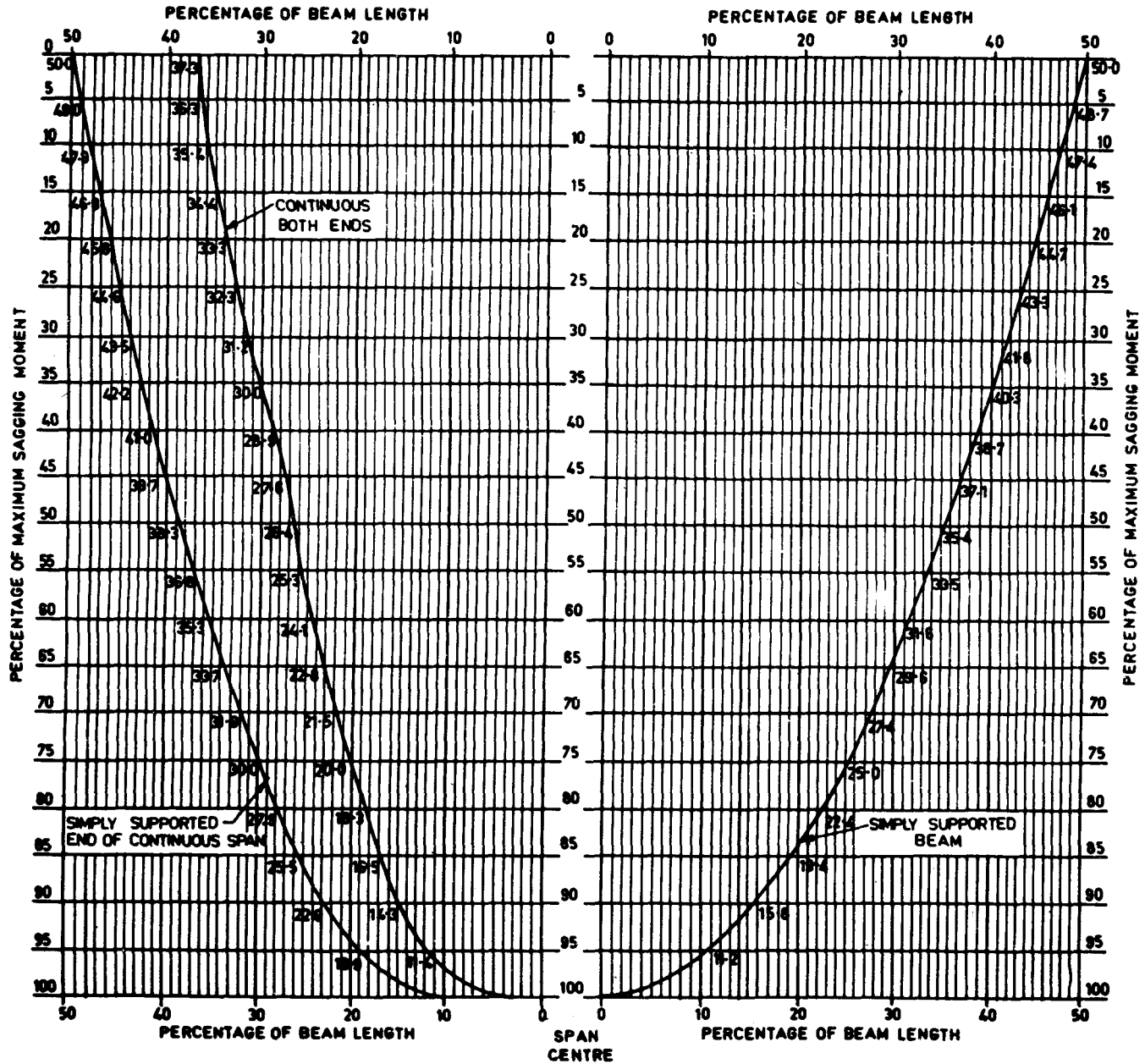

FIG. 4.23 STANDARD BENDING MOMENT DIAGRAMS (BASED ON UDL)

anchorages of the bars of a bundle can only be straight anchorages.

4.8.3 *Curtailment* — Bars in a bundle shall terminate at different points spaced apart by not less than 40 times the bar diameter except for bundles stopping at a support (see Fig. 4.24).

4.8.4 *Splicing* — In case of bundled bars, lapped splices of bundled bars shall be made by splicing one bar at a time, such individual splices within a bundle shall be staggered. For bundles of 2, 3 or 4 bars, the staggering distance should be 1.2, 1.3 and 1.4 times the anchorage length of the individual bars respectively.

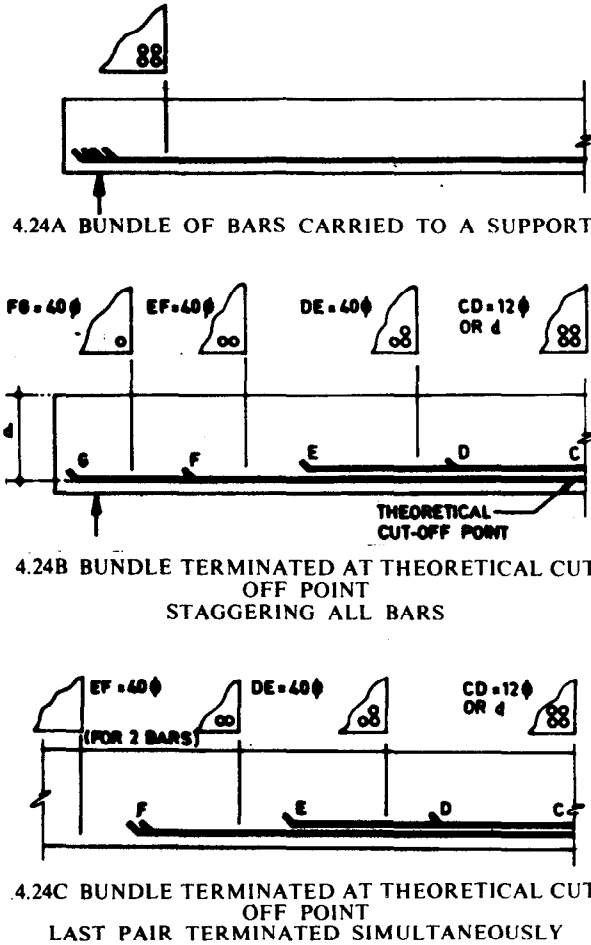

FIG. 4.24 CURTAILMENT OF BUNDLED BARS

SECTION 5
Bar Bending Schedule
(Including Do's and Dont's in Detailing)

SECTION 5

BAR BENDING SCHEDULE (INCLUDING DO'S AND DONT'S IN DETAILING)

5.1 Bar bending schedules are very important out of detailing and should give the following information:

- a) Identification of the structural member(s),
- b) Position of the bars in the structure,
- c) The bar mark,
- d) The diameter or size of bar,
- e) The number of bars of one type in each structural member,
- f) The total number of bars of each type,
- g) The total straight length of the bar,
- h) The shape and bending dimensions of the bar,
- j) The details of bar chairs can also be included, and
- k) Remarks, if any.

5.2 Schedules

5.2.1 The reinforcement of slabs, beams and other parts of structures may be effectively shown on working drawings in a tabular form, known as a schedule. The schedule is a compact summary of the dimensions of the concerned structural part, all the bars complete with the number of pieces, shape and size, lengths and bending details from which fabrication details may be easily worked out. The dimensioning procedure for different bar shapes as shown in Tables 5.1 to 5.7 may be followed.

NOTE— The value of length is the length of straight bar from which the actual shape will be bent or for a straight bar, the length of that bar. This length will be equal to the sum of individual overall lengths of the straight portions of each shape

5.2.2 A schedule shall be supplemented with diagrams and sketches wherever necessary. Where bars of different dimensions are used, the exact arrangement of the reinforcement shall be shown by means of clear diagrams. No abbreviation or symbol shall be used in a schedule without proper explanation.

5.2.3 For small structures detailed on a single sheet, the schedule may be placed in the upper left corner of the drawing. For larger structures requiring more than one drawing, the complete schedule may appear on the last sheet of the details, or if the size of the structure warrants,

separate schedules may be prepared for each unit (foundation, abutments, piers, etc) on the drawing covering that specific unit of the structure.

5.3 Beams, Girders and Joists — Details of reinforcement for beams, girders and joists are usually shown in schedules. The schedules should show the number, mark and location of member; number, size, position and length of straight bars; number, size, position, bending details and total length of bent bars and stirrups; size, shape and spacing of bar supports; and any other special information necessary for proper fabrication and placement of the reinforcement (*see* Table 5.8). Care shall be taken not to omit any controlling dimension such as overall length of the bar, height of the bent bar and location of bar with respect to supporting members where the bar is not placed symmetrically. The schedule should also include special notes on bending and any special information, such as the requirements of laps, two layers of steel, etc.

5.4 Slabs — The reinforcement for slabs is generally indicated on the plan, with details for the various types of bent bars shown in a schedule (*see* Table 5.8). The schedule shall be similar to that for bars in beams, except that the number of bars may also be obtained from the plan. Panels exactly alike shall be given an identifying mark or so specified in the schedule.

5.4.1 In skewed panels, bars shall be fanned to maintain given spacing in the mid span. Additional bars for reinforcing the openings shall be as shown on plan (*see* Section 9).





5.4.2 In case of welded wire fabric sheet in slab panels, a schedule may also be included in the structural drawing indicating the mesh sizes (length and width) and fitting details for welded wire fabric sheets for different slab panels. A typical schedule is given in Table 5.9.

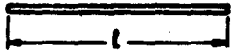
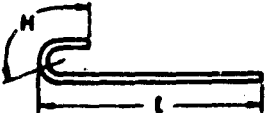
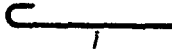
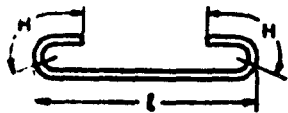

5.5 Walls — The reinforcement for walls shall be indicated on the plan, elevation and section with the details for various types of bent bars shown in schedule in a manner similar to that for beams and slabs.

5.6 Columns — The reinforcement for columns may be shown in a column schedule. Piles and pile caps should be treated as separate units and separate details or schedule or both may be provided. The main schedule may be supplemented with a smaller schedule for ties and

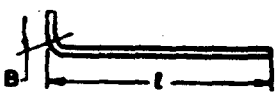
TABLE 5.1 MEASUREMENT OF BENDING DIMENSIONS OF BARS FOR REINFORCED CONCRETE

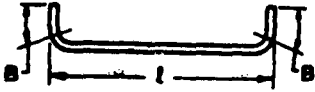
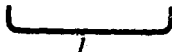
(Clause 5.2.1)

| REF NO. | METHOD OF MEASUREMENT OF BENDING DIMENSIONS | APPROX TOTAL LENGTH OF BAR (L) MEASURED ALONG CENTRE LINE | SKETCH AND DIMENSIONS TO BE GIVEN IN SCHEDULE |
|---------|---|---|--|
| A |  | l | STRAIGHT |
| B |  | $l + H$ |  |
| C |  | $l + 2H$ |  |
| D |  | $l + B$ |  |
| E |  | $l + 2B$ |  |

NOTE 1 Where a hook/bend is to be formed at right angles to the plane in which the bending sketch of the bar is drawn in the schedule, the hook/bend shall be indicated as below and marked either 'hook/bend up' or 'hook/bend down':
 Bend Hook up  Bend/ Hook down 

NOTE 2 H and B refer to hook allowance and bend allowance respectively.

TABLE 5.2 MEASUREMENT OF BENDING DIMENSIONS OF BARS FOR REINFORCED CONCRETE

(Clause 5.2.1)

| REF No. | METHOD OF MEASUREMENT OF BENDING DIMENSIONS | APPROX TOTAL LENGTH OF BAR (L) MEASURED ALONG CENTRE LINE | SKETCH AND DIMENSIONS TO BE GIVEN IN SCHEDULE |
|---------|---|---|---|
| A | | <p>Where C is more than 3D</p> $A + C + E$ | |
| B | | <p>If angle with horizontal is 45° or less, and R is 12d or less</p> $A + C + E + 2H \text{ or } l + 2H + C - \sqrt{C^2 - D^2}$ <p>(If l is specified, A or E is omitted)</p> | <p>(see Note 2)</p> |
| C | | <p>If angle with horizontal is 45° or less, and R is 12d or less</p> $A + C_1 + C_2 + E + F + 2H \text{ or } l + C_1 + C_2 + 2H - \sqrt{C_1^2 - D_1^2} - \sqrt{C_2^2 - D_2^2}$ <p>(If l is specified, A, E or F is omitted)</p> | <p>(see Note 2)</p> |

NOTE 1 -- Where a hook/bend is to be formed at right angles to the plane in which the bending sketch of the bar is drawn in the schedule, the hook/bend shall be indicated as below and marked either 'hook/bend up' or 'hook/bend down'



Bend Hook up Bend/ Hook down

NOTE 2 -- The internal radius R shall be specified if it is other than standard hook and bend.

NOTE 3 -- H and B refer to hook allowance and bend allowance respectively.

TABLE 5.3 MEASUREMENT OF BENDING DIMENSIONS OF BARS FOR REINFORCED CONCRETE

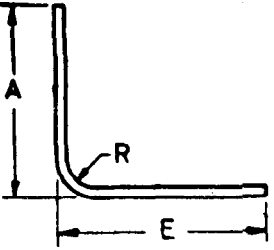
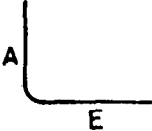
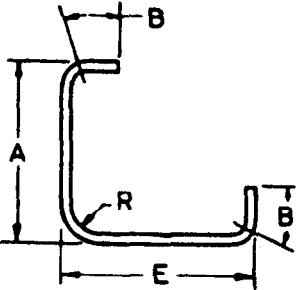
(Clause 5.2.1)

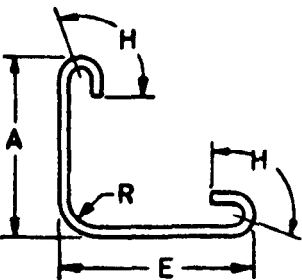
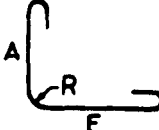
| REF NO. | METHOD OF MEASUREMENT OF BENDING DIMENSIONS | APPROX TOTAL LENGTH OF BAR (L) MEASURED ALONG CENTRE LINE | SKETCH AND DIMENSIONS TO BE GIVEN IN SCHEDULE |
|---------|---|---|--|
| A |  | $A + E - \frac{1}{2}R - d$ |  (See Notes 2 and 3) |
| B |  | $A + E - \frac{1}{2}R - d + 2B$ |  (See Notes 2 and 3) |
| C |  | $A + E - \frac{1}{2}R - d + 2H$ |  (See Notes 2 and 3) |



NOTE 1 - Where a hook/bend is to be formed at right angles to the plane in which the bending sketch of the bar is drawn in the schedule, the hook/bend shall be indicated as below and marked either 'hook/bend up' or 'hook/bend down':
 Bend Hook up ← Bend Hook down ←

NOTE 2 - The internal radius R shall be specified if it is other than standard hook and bend.

NOTE 3 - H , B and d refer to hook allowance, bend allowance and nominal size of bar respectively.

TABLE 5.4 MEASUREMENT OF BENDING DIMENSIONS OF BARS FOR REINFORCED CONCRETE

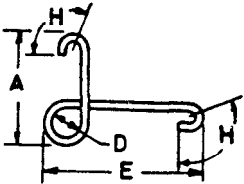
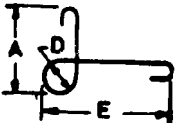
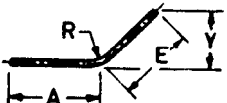
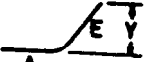
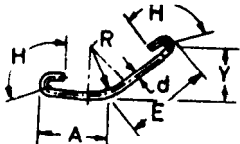
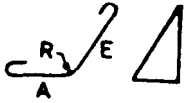
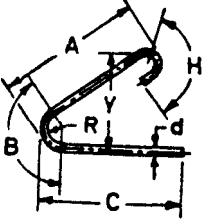
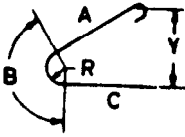
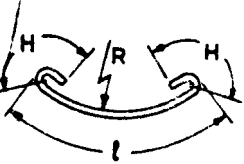
(Clause 5.2.1)

| REF No. | METHOD OF MEASUREMENT OF BENDING DIMENSIONS | APPROX TOTAL LENGTH OF BAR (L) MEASURED ALONG CENTRE LINE | SKETCH AND DIMENSIONS TO BE GIVEN IN SCHEDULE |
|---------|---|--|--|
| A |  | $A + E + 1\frac{1}{3}D + 2H$ |  |
| B |  | <p>If angle with horizontal is 45° or less</p> $A + E$ |  <p>(See Note 2)</p> |
| C |  | <p>If angle with horizontal is 45° or less and R is 12d or less</p> $A + E + 2H$ <p>If angle is greater than 45° and R exceeds 12d, L to be calculated</p> |  <p>(See Note 2)</p> |
| D |  | <p>If angle with horizontal is 45° or less</p> $A + B + C + H - 2(R + d)$ <p>If angle is greater than 45° and R exceeds 12d, L to be calculated</p> |  <p>(See Note 2)</p> |
| E |  | $l + 2H$ |  <p>(See Note 2)</p> |

NOTE 1 Where a hook bend is to be formed at right angles to the plane in which the bending sketch of bar is drawn in the schedule, the hook bend shall be indicated as below and marked either 'hook/bend up' or 'hook/bend down':

Bend Hook up  Bend Hook down 



NOTE 2 The internal radius R shall be specified if it is other than standard hook and bend.

NOTE 3 H and B refer to hook allowance and bend allowance respectively.

NOTE 4 Dimensions A and Y should be practical dimensions to enable the angle of the bend to be determined.

TABLE 5.5 MEASUREMENT OF BENDING DIMENSIONS OF BARS FOR REINFORCED CONCRETE

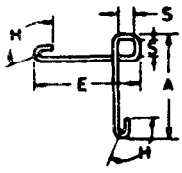
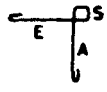
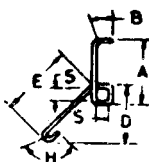

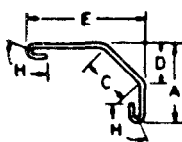
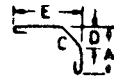
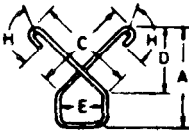
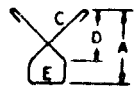
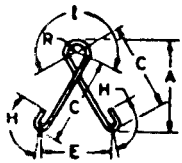
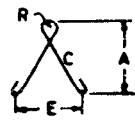
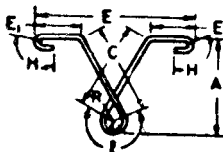
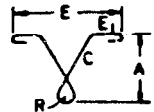



(Clause 5.2.1)

| REF. No. | METHOD OF MEASUREMENT OF BENDING DIMENSIONS | APPROX TOTAL LENGTH OF BAR (<i>L</i>) MEASURED ALONG CENTRE LINE | SKETCH AND DIMENSIONS TO BE GIVEN IN SCHEDULE |
|----------|---|--|--|
| A |  | $A + E + 2S + 2H + d$ |  (See Notes 1 and 2) |
| B |  | $A + E + 3S + 2d + B + H$ |  (See Notes 1 and 2) |
| C |  | $A + E + C + 2H - \sqrt{C^2 - D^2} - D$ |  (See Note 1) |
| D |  | $E + 2(A - D + C + H)$ |  (See Note 1) |
| E |  | $l + 2C + 2H$ |  (See Note 1) |
| F |  | $2C + 2E_1 + l + 2H$ |  (See Note 1) |

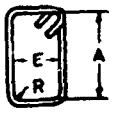
NOTE 1 The internal radius *R* shall be specified if it is other than standard hook and bend.
 NOTE 2 *H*, *B* and *d* refer to hook allowance, bend allowance and a nominal size of bar respectively.

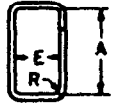
TABLE 5.6 MEASUREMENT OF BENDING DIMENSIONS FOR BINDERS, STIRRUPS, LINKS AND THE LIKE FOR REINFORCED CONCRETE

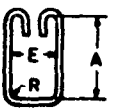
(Clause 5.2.1)

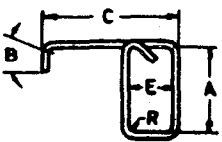
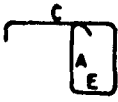
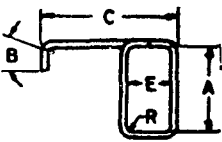
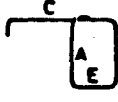
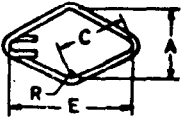
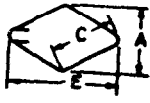
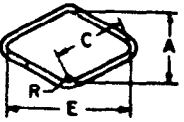
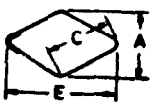
| REF NO. | METHOD OF MEASUREMENT OF BENDING DIMENSIONS | APPROX TOTAL LENGTH OF BAR (L) MEASURED ALONG CENTRE LINE | SKETCH AND DIMENSIONS TO BE GIVEN IN SCHEDULE |
|---------|---|---|---|
| A |  | $2(A+E)+4d$ |  (See Notes 1 and 3) |
| B |  | $2(A+E)+20d$ |  (See Notes 1 and 3) |
| C |  | $2(A+E)+28d$ |  (See Notes 1 and 3) |
| D |  | $2A+E+C+12d+B$ |  (See Notes 1 and 2) |
| E |  | $2A+E+C+9d+B$ |  (See Notes 1 and 3) |
| F |  | $4C+24d$ |  (See Notes 1 and 3) |
| G |  | $4C+20d$ |  (See Notes 1 and 3) |

NOTE 1 The internal radius *R* of the corners of binders, stirrups, etc, shall be specified if it is other than standard hook and bend.

NOTE 2 If the form of the bar is such that there may be doubt as to which is the inside of the bar, arrows should be shown on the bending schedule and the dimension stated with the suffix OD or ID (outside or inside dimension).

NOTE 3 *B* and *d* refer to bend allowance and nominal size of bar respectively.

TABLE 5.7 MEASUREMENT OF BENDING DIMENSIONS FOR BINDERS, STIRRUPS, LINKS AND THE LIKE FOR REINFORCED CONCRETE

(Clause 5.2.1)

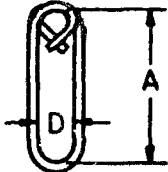
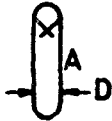
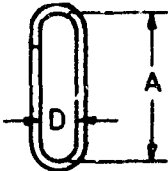
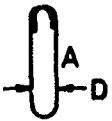
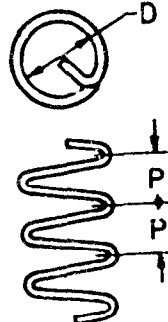
| REF NO. | METHOD OF MEASUREMENT OF BENDING DIMENSIONS | APPROX TOTAL LENGTHS OF BAR (<i>L</i>) MEASURED ALONG CENTRE LINE | SKETCH AND DIMENSIONS TO BE GIVEN IN SCHEDULE |
|---------|--|---|---|
| A |  | $2A + 3D + 22d$ |  (See Note) |
| B |  | $2A + 3D + 22d$ |  (See Note) |
| |  | <p>Where <i>P</i> is not greater than $D/5$</p> $N \pi (D + d) + 8d$ <p><i>N</i> = number of complete and fractional turns <i>D</i> = internal dia <i>P</i> = pitch of helix <i>d</i> = size of bar</p> | — |

NOTE — *d* refers to nominal size of bar.

bent bars, diagrams showing the arrangement and bending of the ties, and any special feature of the construction pertinent to the fabrication and placing of the column reinforcement. In case of rectangular column the reinforcement details may be indicated with reference to framing plan. In case of square columns designed for bending and axial load with unequal reinforcement in two directions, detailed plan should be given showing the reinforcement, the beams framing into the column, and other salient reference lines so that the bars are placed in correct places.

In addition to showing size and normal spacing of column ties, the designer shall also show any additional ties required for special conditions such as splices, offset bends, etc.

5.7 Dowels and Bar Supports — Dowels and bar supports, spacer bars, bar chairs, etc, should be specifically listed on the structural drawing and should be scheduled in that portion of the structure in which they are first required so that they can be delivered with the reinforcement and are available for placement at proper time. Footings dowels shall be scheduled with footings rather than in column schedules.

5.8 Other Structures — On some types of structures, such as bridges, tanks, sewers and conduits, and certain components of buildings such as stairs, special procedure may be used and adopted to the particular structure. The principal object is to show the reinforcement in a simple, clear and easy manner. This may be accomplished

TABLE 5.8 TYPICAL BAR BENDING SCHEDULE FOR BEAMS, SLABS AND COLUMNS

(Clause 5.3)

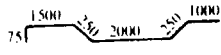
| MARK AND LOCATION OF MEMBER (see Key Plan) (1) | DRAWING REFERENCE (2) | NO. OF MEMBER (3) | BAR TYPE (4) | BAR NO. (5) | BAR SIZE (6) | CUTTING BAR LENGTH (7) | NO. OF BARS PER MEMBER (8) | TOTAL NO. OF BARS (9) | TOTAL WEIGHT OF BARS (10) | DETAILED (DIMENSIONED) SKETCH (11) | REMARKS (12) |
|--|--------------------------|----------------------|-----------------|----------------|-----------------|---------------------------|-------------------------------|--------------------------|------------------------------|---|-----------------|
| S_b 4 Floor 1 and S_b 6 | Drg No. Stc... | 2 | $S_1 \phi$ | 43 | 25 | 40 cm | 10 | 20 | |  | |
| B_m 6 Floor 1 B_m 7 B_m 8 and B_m 10 | Drg No. Stc... | 4 | $B_1 \#$ | 75 | 16 | 200 cm | 8 | 32 | | | |

S_1 = straight bars without hooks.
 B_1 = Bent bar with hooks at both ends.

TABLE 5.9 TYPICAL SCHEDULE FOR SLAB USING WELDED WIRE FABRIC AS REINFORCEMENT

(Clause 5.4.2)

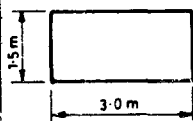
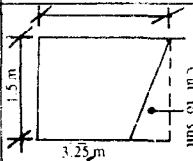
| MARK AND LOCATION OF MEMBER (1) | DRAWING REFERENCE (2) | NO. OF MEMBERS/PANELS (3) | FABRIC DESIGNATION NO. AS PER IS: (4) | FABRIC REFERENCE (5) | NUMBER IN EACH MEMBER/PANEL (6) | TOTAL NO. (7) | WIDTH (8) | LENGTH (9) | CUTTING (10) | REMARKS (11) |
|---|--------------------------|------------------------------|--|-------------------------|------------------------------------|------------------|--------------|---------------|---|--|
| Mark S_b 7, S_b 8 Location Floor 2 | Drg No. Stc... | 2 | 42 | J_1 | 4 | 8 | 1.5 m | 3 m |  | Hard-drawn steel wire fabric conforming to IS: 1566-1982 |
| S_b 10 Floor 2 | Drg No. Stc... | 1 | 42 | J_5 | 1 | 1 | 1.5 m | 3.25 m |  | |

by a small detailed sketch of each bar or type of bar with a table of dimensions.

5.9 Schedule Layout— A typical form of schedule for beams, slabs and columns is shown in Table 5.8 and Table 5.9 shows another typical form schedule for slab using welded wire fabric as reinforcement. Also an example of typical bar bending schedule is given in Table 5.10.

5.9.1 International Standard 'ISO : 4066-1977 'Building and civil engineering drawings— Bar scheduling' establishes a system of scheduling of reinforcing bars comprising the following aspects:

- a) the method of indicating dimensions;
- b) a code system of bar shapes;
- c) a list of preferred shapes; and
- d) the bar schedule form.

This standard is reproduced in Appendix B as a supplement to the information contained in this Section.

5.10 Do's and Dont's for Detailing

5.10.1 Do's—General

- a) Prepare drawings properly and accurately. If possible label each bar and show its shape for clarity.
- b) Prepare bar-bending schedule, if necessary.
- c) Indicate proper cover to reinforcement.
- d) Decide location of openings/hole and supply adequate details for reinforcement around openings.
- e) Commonly available size of bars and spirals shall be used for reinforcement. For a single structural member the number of different sizes of reinforcement bar should be minimum.
- f) The grade of reinforcement bars shall be clearly mentioned in the structural drawing.
- g) For mild steel plain bars U-type hooks and for deformed bars L-type hooks may be adopted. Deformed bars need not have hook at their ends.
- h) Bars shall have smooth curved edges at the point of bend.
- j) In case of bundled bars, lapped splice of bundled bars shall be made by splicing one bar at a time; such individual splices within a bundle shall be staggered.
- k) When reinforcement is left exposed for future construction, it should be adequately protected from corrosion and weathering action.
- m) Congestion of steel should be avoided at points where members intersect and make

certain that all reinforcement shown can be properly placed.

- n) Make sure that hooked and bent bars can be placed and have adequate concrete protection.
- p) Make sure that bent bars are not so large and unwieldy that they cannot be transported.
- q) Indicate all expansion, contraction and construction joints on framing plans and provide details for such joints.
- r) Where a section is not on the same sheet as the plan from which it is taken, use a clearly defined system of cross-reference for locations of sections and details.
- s) Show enlarged details at corners, intersections of walls, beam and column joint, and at similar special situations.

5.10.2 Do's—Beams and Slabs

- a) Where splices are provided in reinforcing bars, they shall be, as far as possible, away from the sections of maximum stress and shall be staggered.
- b) Where the depth of a beam exceeds 750 mm in case of beams without torsion and 450 mm with torsion, side face reinforcement shall be provided.
- c) In two-way slab, reinforcement parallel to the short span of the slab shall be placed in the bottom layer at mid-span and in the top layer at support.
- d) All spacing shall be centre-to-centre spacing of bars.
- e) Deflection in slabs/beams may be reduced by providing compression reinforcement.
- f) Only closed stirrups shall be used for transverse reinforcement for members subject to torsion and for members likely to be subjected to reversal of stress.
- g) At beam-column intersections ensure that the main beam bars avoid the main column bars.
- h) At beam-beam intersections, main reinforcement may be so arranged that layers in mutually perpendicular beams are at different levels.
- j) To accommodate bottom bars, it is good practice to make secondary beams shallower than main beams, at least by 50 mm.
- k) If it is required the beam cages may be pre-assembled with splice bars.

5.10.3 Do's—Columns

- a) A reinforced column shall have at least six bars of longitudinal reinforcement for using in transverse helical reinforcement.

TABLE 5.10 TYPICAL EXAMPLE OF A BAR BENDING SCHEDULE

(Clause 5.9)

| MEMBER | MARK | NO. OF BARS | DIAMETER IN mm | LENGTH IN m/PIECE | TOTAL LENGTH IN m | | | | | | | | BAR DETAILS | REMARKS | | |
|-----------------------------|------|-------------|----------------|-------------------|-------------------|-------|-------|-------|-------|-------|-------|-------|-------------|---------|--|--|
| | | | | | #8 | #6 | #20 | #14 | #10 | #8 | #16 | | | | | |
| SLAB a | 1 | 12 | 8 | 2.90 | 34.80 | | | | | | | | | | | |
| | 2 | 12 | 8 | 3.62 | 43.44 | | | | | | | | | | | |
| | 3 | 12 | 8 | 0.90 | 10.80 | | | | | | | | | | | |
| | 4 | 11 | 8 | 5.50 | 60.50 | | | | | | | | | | | |
| | 5 | 11 | 8 | 0.85 | 9.35 | | | | | | | | | | | |
| | 6 | 11 | 8 | 1.70 | 18.70 | | | | | | | | | | | |
| | 7 | 5 | 6 | 1.45 | 7.25 | | | | | | | | | | | |
| | 8 | 5 | 6 | 4.00 | 20.00 | | | | | | | | | | | |
| SLAB b | 9 | 12 | 8 | 2.80 | 33.60 | | | | | | | | | | | |
| | 10 | 12 | 8 | 4.27 | 51.24 | | | | | | | | | | | |
| | 11 | 4 | 8 | 2.80 | 11.20 | | | | | | | | | | | |
| | 12 | 4 | 8 | 3.52 | 14.08 | | | | | | | | | | | |
| BEAM 11 | 13 | 2 | 20 | 6.25 | | | 12.50 | | | | | | | | | |
| | 14 | 1 | 20 | 8.83 | | | 8.83 | | | | | | | | | |
| | 15 | 1 | 20 | 8.46 | | | 8.46 | | | | | | | | | |
| | 16 | 1 | 20 | 8.83 | | | 8.83 | | | | | | | | | |
| | 17 | 2 | 14 | 1.90 | | | | 3.80 | | | | | | | | |
| | 18 | 2 | 10 | 2.80 | | | | | 5.60 | | | | | | | |
| | 19 | 2 | 8 | 5.80 | 11.60 | | | | | | | | | | | |
| | 20 | 24 | 8 | 1.59 | | | | | | | 38.16 | | | | | |
| COLUMN B ₁ | 21 | 3 | 16 | 4.00 | | | | | | | | 12.00 | | | | |
| | 22 | 3 | 16 | 4.00 | | | | | | | | 12.00 | | | | |
| | 23 | 2 | 20 | 2.20 | | | 4.40 | | | | | | | | | |
| | 24 | 2 | 20 | 2.20 | | | 4.40 | | | | | | | | | |
| | 25 | 12 | 8 | 1.31 | | | | | | | | 15.72 | | | | |
| | 26 | 2 | 8 | 1.29 | | | | | | | | 2.58 | | | | |
| TOTAL LENGTH IN m/DIAMETER | | | | | 299.31 | 27.25 | 47.42 | 3.80 | 5.60 | 56.46 | 24.00 | | | | | |
| WEIGHT IN kg/m | | | | | 0.395 | 0.222 | 2.464 | 1.208 | 0.617 | 0.395 | 1.578 | | | | | |
| TOTAL WEIGHT IN kg/DIAMETER | | | | | 118 | 6 | 117 | 5 | 3 | 22 | 38 | | | | | |

- b) Spacing of longitudinal bars in column shall be along the periphery of the column, as far as practicable.
- c) Column bars of diameters larger than 36 mm in compression can be spliced with dowels at the footing with bars of smaller sizes and of necessary area.
- d) A dowel shall extend into a column, a distance equal to the development length of the column bar and into footing a distance equal to development length of the dowel.
- e) Keep outer dimensions of column constant, as far as possible, for re-use of forms.
- f) Preferably avoid use of two grades of vertical bars in the same element.

5.10.4 *Don't's—General*

- a) Reinforcement shall not extend across an expansion joint and the break between the sections shall be complete.
- b) Flexural reinforcement, preferably, shall not be terminated in a tension zone. If such case is essential, the condition as given in Section 4 shall be satisfied.
- c) Lap splices shall not be used for bars larger than 36 mm diameter except where welded.
- d) Bars larger than 36 mm diameter shall not be bundled.
- e) Where dowels are provided their diameter shall not exceed the diameter of the column bars by more than 3 mm.
- f) Where bent bars are provided, their contribution towards shear resistance shall not be more than half that of the total shear reinforcement.
- g) Different types of reinforcing bars such as deformed bars and plain bars and various grades like 415 N/mm² and 215 N/mm² should not be used side by side as this practice would lead to confusion at site. However, secondary reinforcement such as links ties and stirrups may be of mild steel throughout, even though the main steel may be of high strength deformed bars.
- h) Under no circumstances should the bending of bars at welds be permitted.

SECTION 6
Foundations

SECTION 6

FOUNDATIONS

6.1 Types of Foundations — The following are types of reinforced concrete foundations, the particular type being chosen depending on the magnitude and disposition of the structural loads, and the bearing capacity of the ground.

- a) *Individual Column Footing* — Generally square in plan but some times rectangular or circular.
- b) *Combined Footing* — Combined footing is a common footing to two or more columns in a line. The placing of reinforcement depends on the shape of the bending moment and shear force diagrams considering the soil pressure and the column loads on the footing.
- c) *Strip Footings* — Under columns or walls.
- d) *Raft Foundation* — Covering the whole plan area of structure, detailing being similar to 2-way reinforced solid floor slabs or flat slabs.
- e) *Pile Foundations* — This includes detailing of pile cap and pile portion.

6.2 Cover — The minimum thickness of cover to main reinforcement shall not be less than 50 mm for surfaces in contact with earth face and not less than 40 mm for external exposed face. However, where the concrete is in direct contact with the soil, for example, when a levelling course of lean concrete is not used at the bottom of footing, it is usual to specify a cover of 75 mm. This allows for the uneven surface of the excavation. In case of raft foundation, whether resting directly on soil or on lean concrete, the cover for the reinforcement shall not be less than 75 mm.

6.3 Minimum Reinforcement and Bar Diameter — The minimum reinforcement according to slab and beam elements as appropriate should be followed, unless otherwise specified. The diameter of main reinforcing bars should be not less than 10 mm.

6.4 Detailing Methods — Foundations should normally be detailed diagrammatically in plan and elevation.

6.4.1 In case of plan, show diagrammatically the location of foundation reinforcement (similar to slabs) as well as starter bars and stirrups (as for columns). It is preferable for column and wall dowels (starter bars), and the foundation reinforcement to be shown on the same drawing.

6.4.2 In case of elevation, show diagrammatically the location of reinforcement as for beams.

In case of pile foundation, detailing of pile is similar to that of columns and detailing of the pile cap supporting on piles is similar to that of footing.

An indication of the type of soil and its assumed bearing capacity may be specified in the drawing.

6.5 Individual Footings — Individual footings (see Fig. 6.1) are generally square and support a central column. Rectangular footings can be used when the space is restricted in one direction. Individual footings of circular and other shapes can also be used. Figure 6.1 gives typical details of a column footing.

6.5.1 Reinforcement Requirements — Total tensile reinforcement shall be distributed across the corresponding resisting section as given below:

- a) In one-way reinforced footing, the reinforcement shall be distributed uniformly across the full width of the footing.
- b) In two-way reinforced square footing, the reinforcement extending in each direction shall be distributed uniformly across the full width of the footing.
- c) In two-way reinforced rectangular footing, the reinforcement in the long direction shall be distributed uniformly across the full width of the footing. For reinforcement in the short direction, a central band equal to the width of the footing shall be marked along the length of the footing and portion of the reinforcement determined in accordance with the equation given below shall be uniformly distributed across the central band:

$$\frac{\text{Reinforcement in central band}}{\text{Total reinforcement in short direction}} = \frac{2}{(y/x) + 1}$$

where y is the long side and x is the short side of the footing.

The remainder of the reinforcement shall be uniformly distributed in the outer portions of the footing.

Figure 6.2 illustrates placing of transverse reinforcement for a rectangular footing.

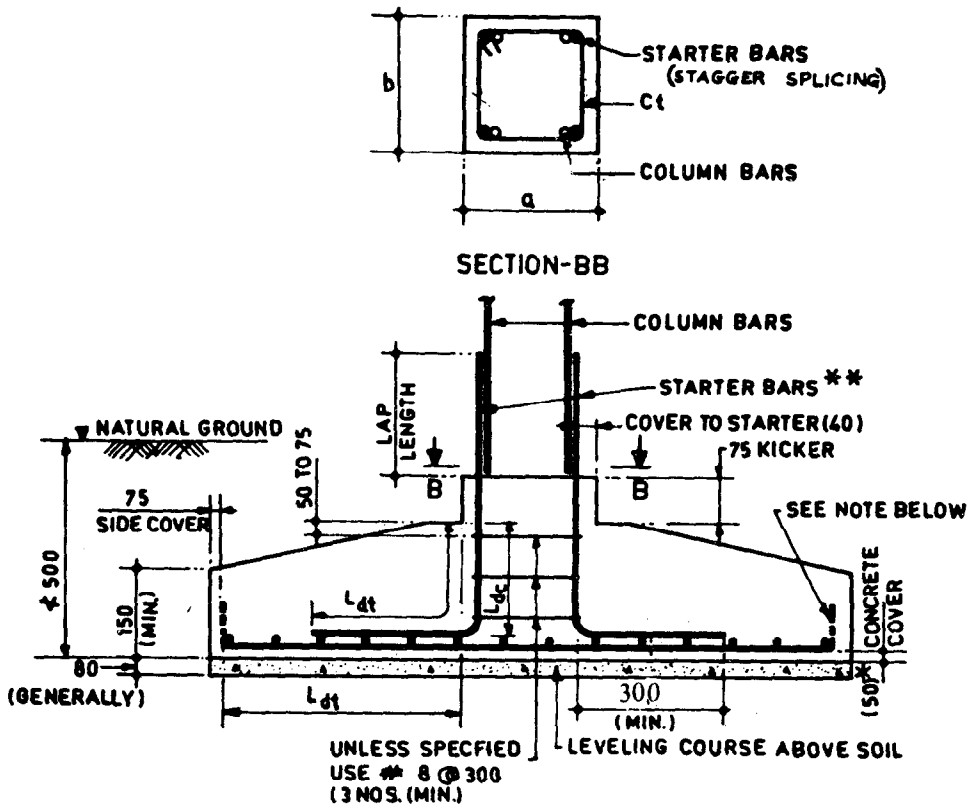

SECTION-AA

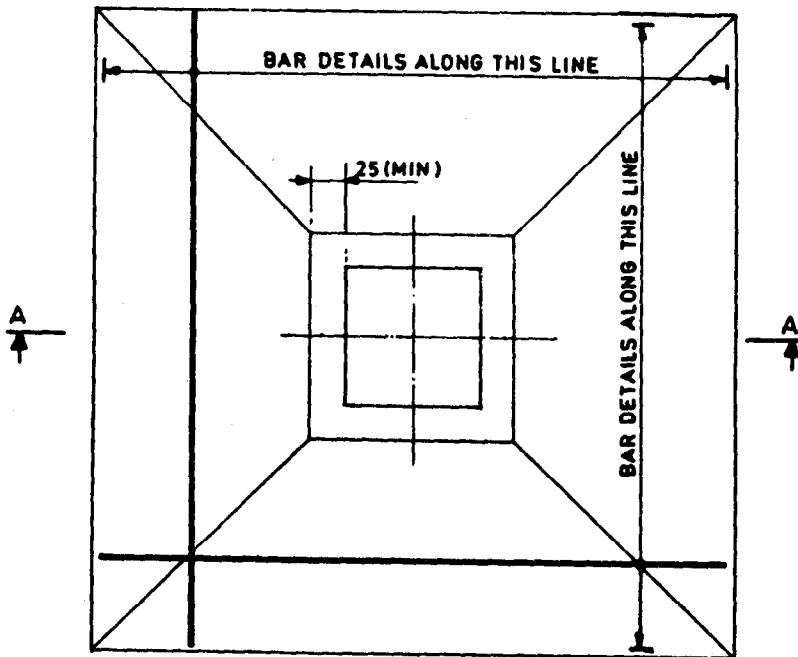

PLAN

L_{dt} = Effective development length considering tension
 L_{dc} = Effective development length considering compression

*Use of starter bars or continuous bars depends upon the distance between the first floor level and the level of foundation.
 NOTE 1 — Provide standard 90° bend, if the bar is required to be bent upwards to get the required development length.
 NOTE 2 — In case a pedestal is provided, the development length is to be considered from the top level of pedestal.

FIG. 6.1 TYPICAL DETAILS OF A COLUMN FOOTING

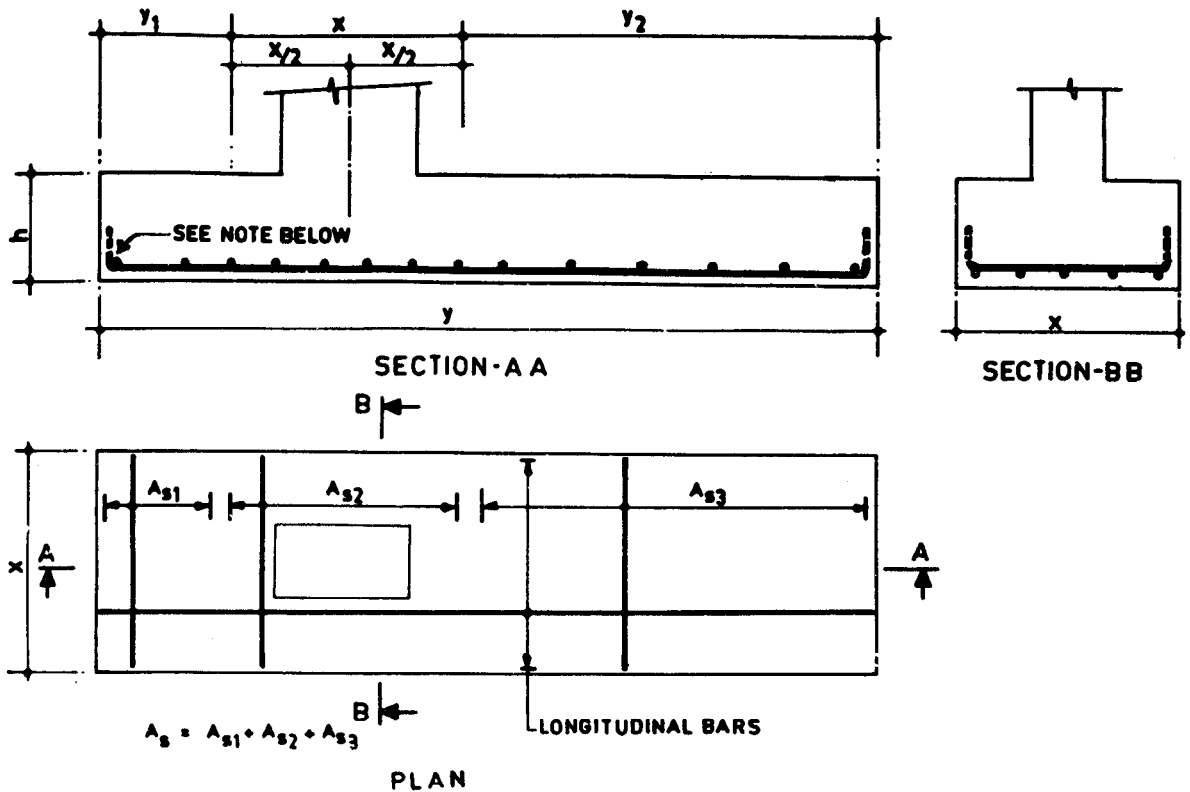

NOTE — Provide standard 90° bend, if the bar is required to be bent upwards to get required development length.

FIG. 6.2 PLACING OF TRANSVERSE REINFORCEMENT FOR A RECTANGULAR FOOTING

6.5.1.1 Vertical reinforcement or dowels — Extended vertical reinforcement or dowels of at least 0.5 percent of the cross-sectional area of the supported column or pedestal with a minimum of 4 bars of 12 mm diameter shall be provided. Where dowels are used, their diameter shall not exceed the diameter of column bars by more than 3 mm.

Column bars of diameter larger than 36 mm in compression can be dowelled at the footings with bars of smaller size of the necessary area. The dowel shall extend into the column a distance equal to the development length of the column bar, and into the footing a distance equal to the development length of the dowel. The development length shall be calculated in accordance with 4.4.2.

For method of detailing see Fig. 6.1.

NOTE — Where the depth of the footing or footing and pedestal combined is less than the minimum development length in compression required for dowels (starter bars) of a certain size, the size of dowels (starter bars) may be suitably decreased and the number of dowels increased to satisfy the required area and development length.

6.5.1.2 To achieve economy, the footings are sloped or stepped towards the edge satisfying the requirements for bending and punching shear. In sloped footing, the slope is generally restricted such that top formwork is not called for in

construction. The thickness at the edges shall not be less than 15 cm for footings on soils, nor less than 30 cm above tops of piles in case of footing on piles.

6.6 Combined Footings

6.6.1 Combined footings become necessary where the external columns of the structure are close to the boundary of an existing structure and also where the footings of individual columns overlap one another. Such foundations (supporting more than one column/pedestal or a continuous wall) shall be proportioned to resist the design loads and individual reactions, in accordance with appropriate design requirements. The detailing requirements as specified in Section 4 for slabs and beams shall be followed as appropriate.

6.6.2 Detailing — For combined footing, detailing of longitudinal and transverse bars is similar to that of beams.

6.6.2.1 Column on edges of footing — To prevent shear failure along the inclined plane (corbel type of failure) in footing, where a column is located on the edge, it is advisable to provide horizontal U-type bars around the vertical starter bars. These bars shall be designed for every such column (see Fig. 6.3).

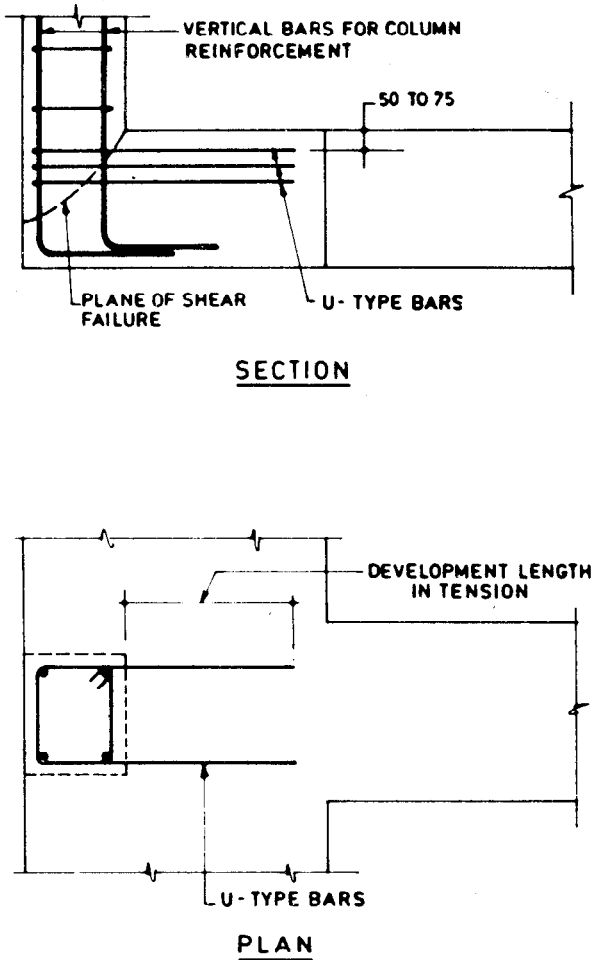

FIG. 6.3 COLUMN ON EDGE OF A FOOTING

6.6.2.2 Figure 6.4 (A, B and C) shows typical arrangement of bars in combined footings.

6.7 Continuous Footing Under Walls— In continuous wall foundations, transverse reinforcement should be provided when the projection of the footing beyond the wall exceeds the thickness of the footing (see Fig. 6.5). It is also recommended that longitudinal reinforcement be provided wherever an abrupt change in the magnitude of the load or variation in ground support or local loose pockets may occur along the footing.

6.8 Raft Foundations— A raft is a foundation unit continuous in two directions, covering an area equal to or greater than the base area of the building. If the raft consists of several parts with varying loads and heights, it is advisable to design the raft with expansion joints between these parts. Joints shall also be provided wherever there is a change in the direction of the raft and should be detailed on the drawing. The detailing

requirements as specified in Section 4 for beams and columns may be followed as appropriate.

6.8.1 Minimum reinforcement in either direction shall not be less than 0.15 percent of the gross sectional area for mild steel reinforcement and 0.12 percent in case of high strength deformed bars.

6.8.2 Detailing— For raft foundation, detail both the longitudinal and transverse bars generally in accordance with the rules for slabs and beams except cover and bar supports. While detailing reinforcement in raft foundation, construction method and sequence of construction are to be specified which should include the following:

- a) Position of construction joints,
- b) Position of movement joints, and
- c) Position of water bar joints.

The location of lap splices in raft should be detailed with care as the direction of bending will differ from suspended members.

6.8.3 Placing of Bar Supports— Where top reinforcement is required, consideration should be given to the method of supporting this with chairs and edge U-bars. This must be carried out in accordance with the specification for the job and should take into account construction sequence, weight of top steel and depth of foundation. The suggested spacing of supports is 30 times the diameter of supporting bars using chairs having diameter of at least 12 mm. The diameter of chairs should be such that they do not bend or buckle under the weight of reinforcement and other incidental loads during construction.

6.8.4 Ducts and Trenches— Where ducts and trenches occur in rafts, special attention should be given to detailing continuity of top reinforcement, specially where moment transfer is required (see Fig. 6.6).

6.9 Pile Foundation

6.9.1 Driven Precast Concrete Pile

- a) The longitudinal reinforcement shall be provided in precast reinforced concrete piles for the entire length. All the main longitudinal bars shall be of the same length with lap welded at joints and should fit tightly into the pile shoe if there is one. Shorter rods to resist local bending moments may be added but the same should be carefully detailed to avoid any sudden discontinuity of the steel which may lead to cracks during heavy driving. The area of main longitudinal reinforcement shall not be less than the following percentages of the cross-sectional area of the piles:

- 1) For piles with length less than 30 times the least width—1.25 percent.

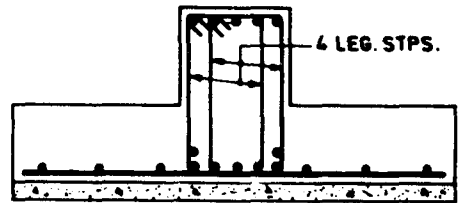
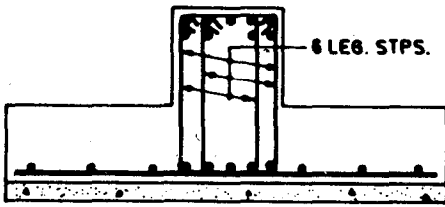
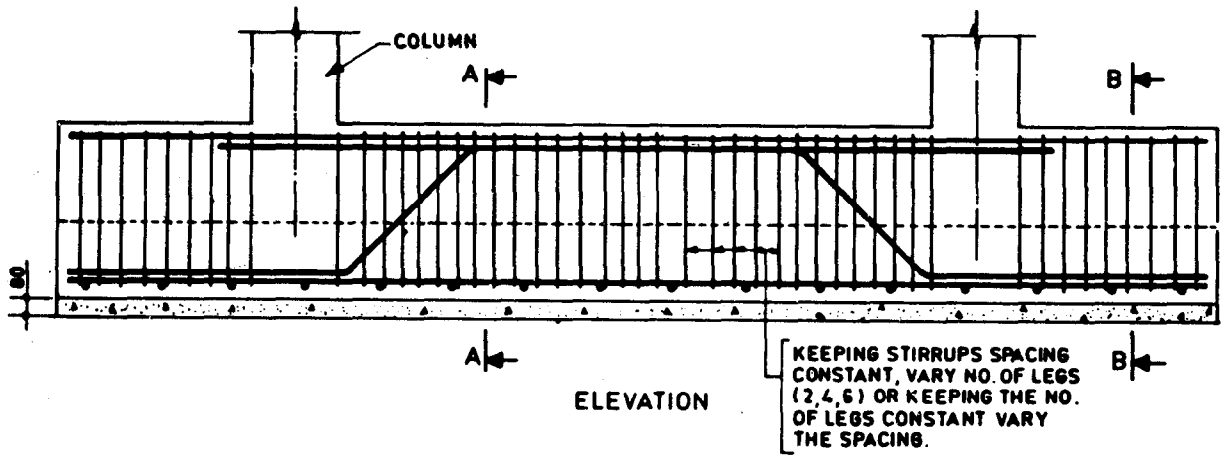

6.4A COMBINED COLUMN FOOTING

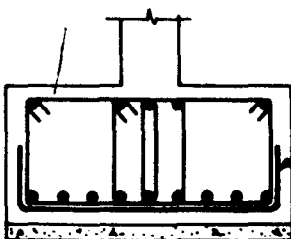
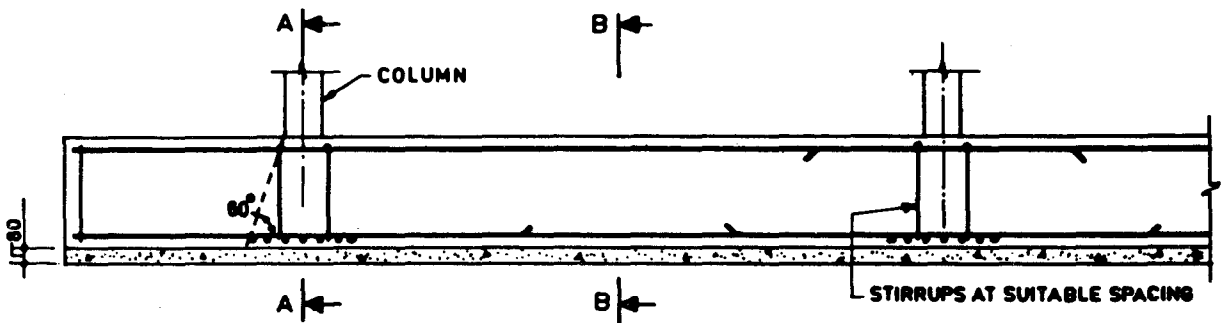

TRANSVERSE BENDING REINFT. AT COLUMNS ONLY.

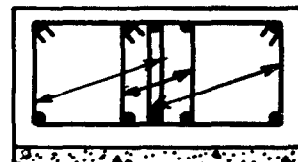

6.4B STRIP FOOTING UNDER COLUMNS

Fig. 6.4 TYPICAL DETAILS OF COMBINED FOOTING (Continued)

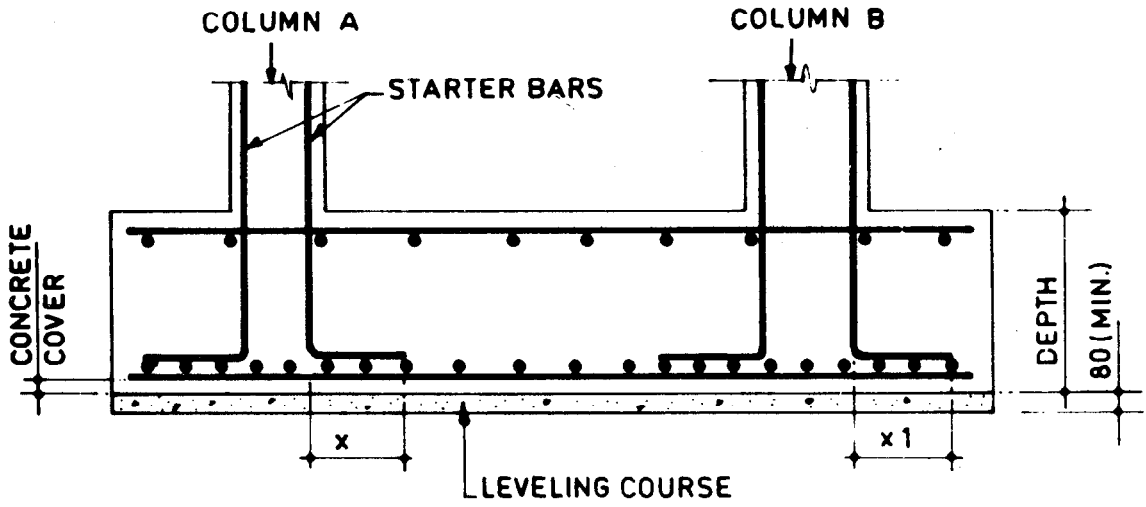

SECTION-BB

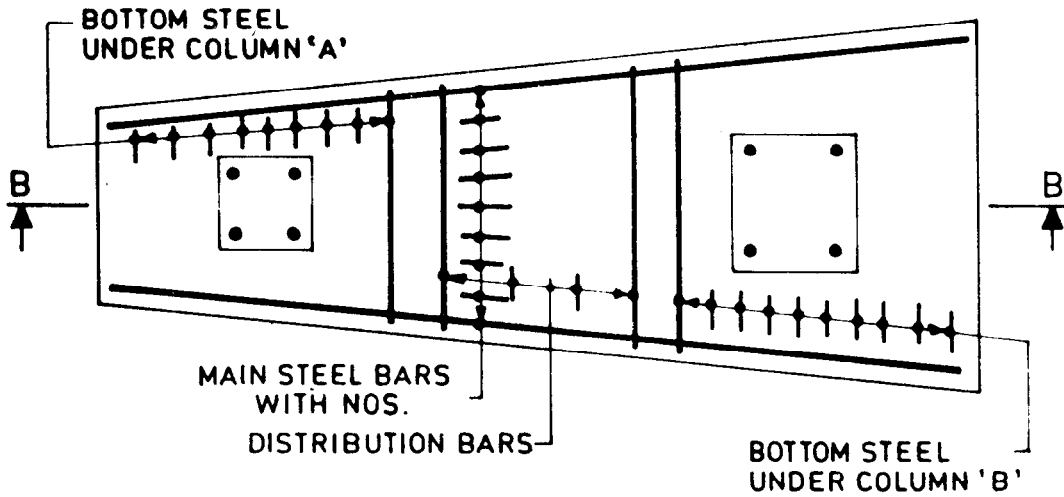

PLAN-BOTTOM STEEL

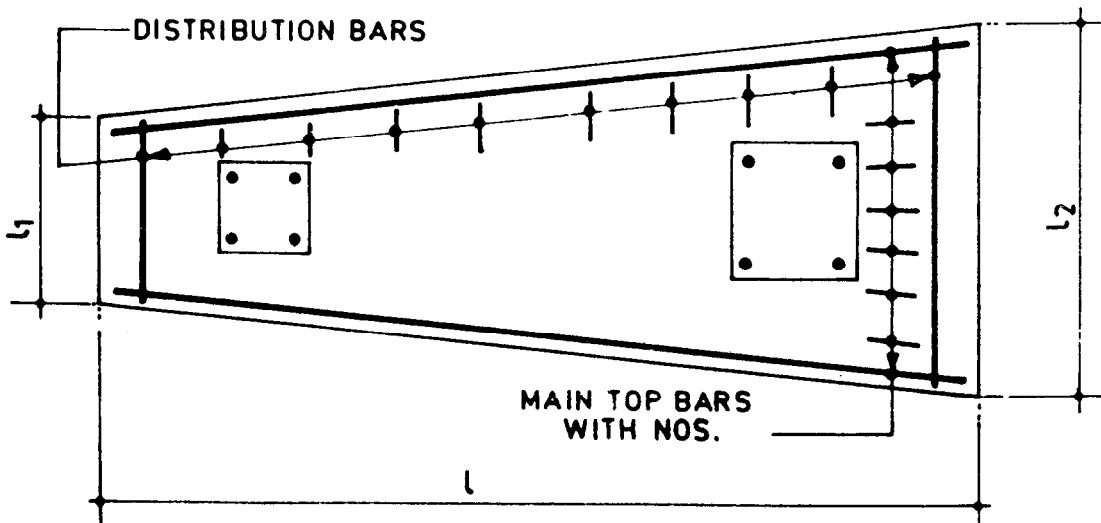

PLAN-TOP STEEL

6.4C TAPERED COMBINED FOOTING STIRRUPS (NOT SHOWN)

FIG. 6.4 TYPICAL DETAILS OF COMBINED FOOTINGS

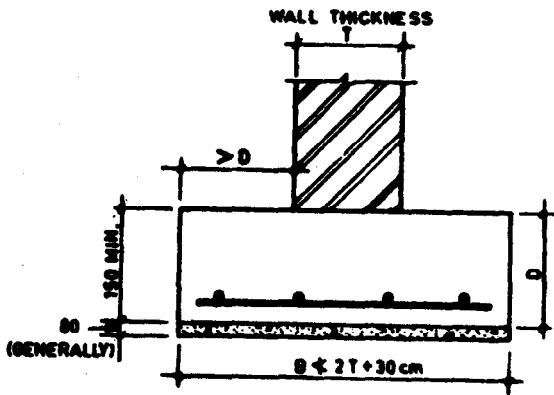

FIG. 6.5 STRIP FOOTING UNDER WALLS

- 2) For piles with length 30 to 40 times the least width—1.5 percent.
 - 3) For piles with length greater than 40 times the least width—2 percent.
- b) The lateral reinforcement is of particular importance in resisting the driving stresses induced in the piles and should be in the form of hoops or links and of diameter not less than 6 mm. The volume of lateral reinforcement shall not be less than the following (see Fig. 6.7):
- 1) At each end of the pile for a distance of about 3 times the least width—not less than 0.6 percent of the gross volume of that part of the pile; and
 - 2) In the body of the pile—not less than 0.2 percent of the gross volume of pile.

The spacing shall be such as to permit free flow of concrete around it. The transition between the close spacing of lateral reinforcement near the ends and the maximum spacing shall be gradually over a length of 3 times the least width of the pile.

The cover of concrete over all the reinforcement including ties should not be less than 40 mm. But where the piles are exposed to sea water or water having other corrosive content, the cover should be nowhere less than 50 mm.

Piles should be provided with flat or pointed co-axial shoes if they are driven into or through ground, such as rock, coarse gravel, clay with cobbles and other soils liable to damage the concrete at the tip of the pile. The shoe may be of steel or cast iron. Shapes and details of shoes depend on the nature of ground in which the pile is driven. In uniform clay or sand the shoe may be omitted.

Where jetting is necessary for concrete piles, a jet tube may be cast into the pile, the tube being connected to the pile shoe which is provided with jet holes. Generally, a central jet is inadvisable, as it is liable to become choked. At least two jet holes will be necessary on opposite sides of the shoe, four holes give best results. Alternatively, two or more jet pipes may be attached to the sides of the pile.

6.9.1.1 Reinforcement requirement—A pile shall be reinforced in the same way as the column, with the main bars on the periphery and secondary bars (binders or links) around main bars. In addition the main bars shall be bent inwards at the lower end and welded to the shoe made of chilled cast iron or steel.

6.9.1.2 Spacer bars—To ensure the rigidity, pile spacer bars shall be used as shown in Fig. 6.8. The spacer bars or forks can be of cast iron, pressed steel or a length of steel pipe with slotted ends to fit the main reinforcing bars. They can be detailed on the drawing, at 1.5 m centres along the full length of the pile. The fork may be placed diagonally at each position across the section as shown in Fig. 6.8.

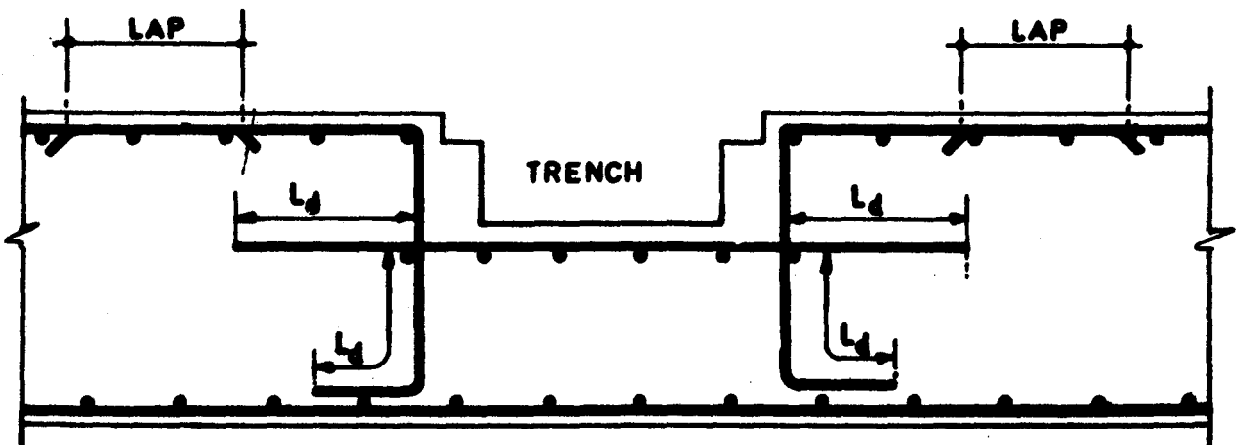

FIG. 6.6 TYPICAL DETAILS AROUND A TRENCH IN RAFT FOUNDATION

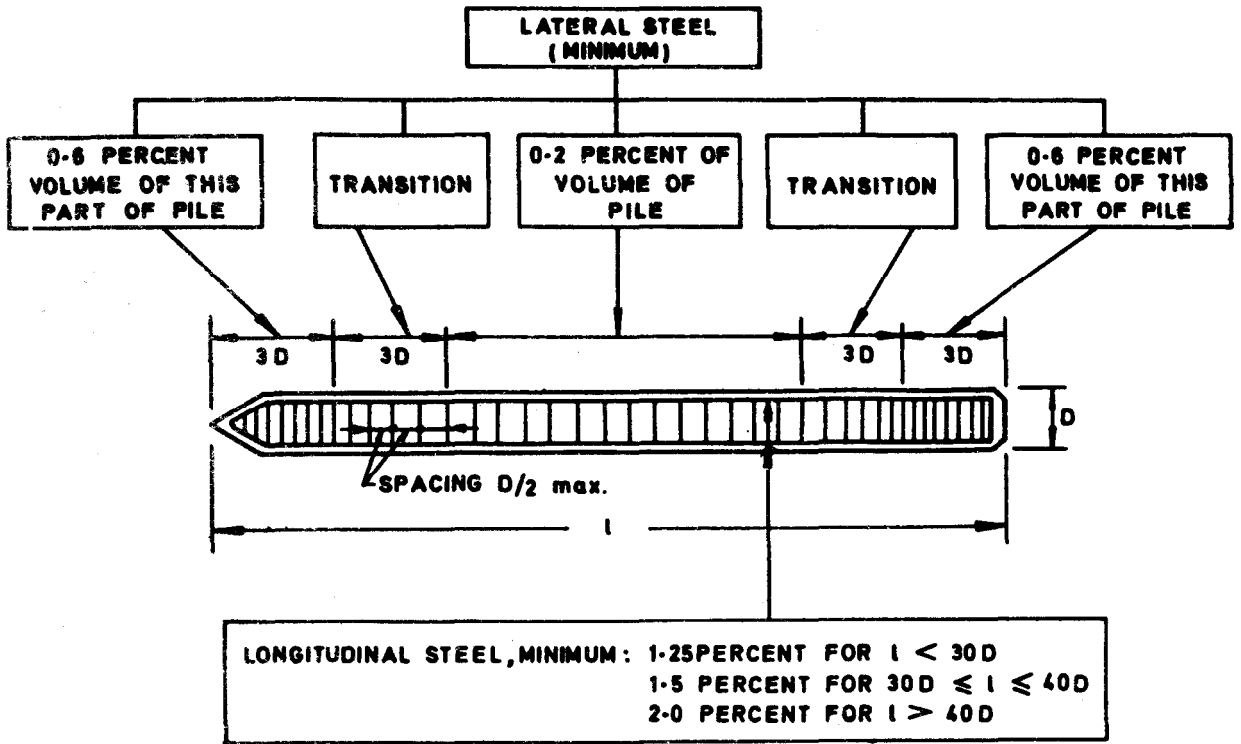

FIG. 6.7 MINIMUM STEEL REQUIREMENTS OF PRECAST CONCRETE PILE

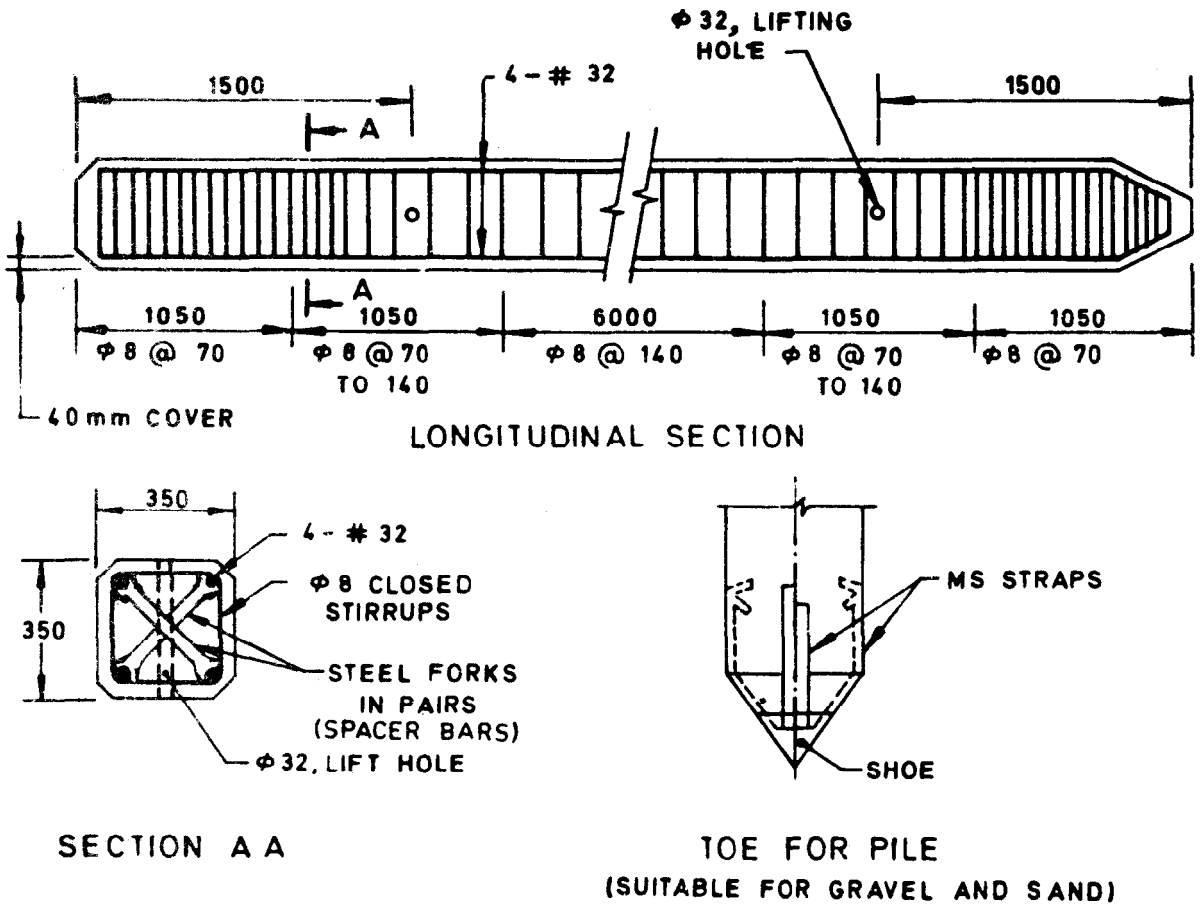

FIG. 6.8 TYPICAL DETAILS OF A PRECAST CONCRETE PILE

6.9.2 Cast-in-situ Piles or Bored Piles

6.9.2.1 Reinforcement requirement — The design of the reinforcing cage vary depending upon the driving and installation conditions, the nature of the subsoil and the nature of load to be transmitted by the shaft, that is, axial or otherwise. The minimum area of longitudinal reinforcement (mild steel or deformed bars) within the pile shaft shall be 0.4 percent of the sectional area calculated on the basis of outside area of casing of the shaft.

The curtailment of reinforcement along the depth of the pile, in general, depends on the type of loading and subsoil strata. In case of piles subject to compressive load only, the designed quantity of reinforcement may be curtailed at appropriate level according to the design requirements. For piles subjected to uplift load, lateral load and moments, separately or with compressive loads, it may be necessary to provide reinforcement for the full depth-of pile. In soft clays or loose sands, or where there is likelihood of danger to green concrete due to driving of adjacent piles, the reinforcement should be provided up to the full pile depth with lap welds at joints regardless of whether or not it is required from uplift and lateral load considerations. However, in all cases, the minimum reinforcement should be provided in the full length of the pile.

Piles shall always be reinforced with a minimum amount of reinforcement as dowels, keeping the minimum bond length into the pile shaft and with adequate projection into the pile cap.

Clear cover to all main reinforcement in pile shaft shall be not less than 50 mm. The laterals of a reinforcing cage may be in the form of links or spirals. The diameter and spacing of the same is chosen to impart adequate rigidity to the reinforcing cage during its handling and installations. The minimum diameter of the links or spirals shall be 6 mm and the spacing of the links or spirals shall be not less than 150 mm.

6.9.3 Under-reamed Piles — The minimum area of longitudinal reinforcement in stem should be 0.4 percent. Reinforcement is to be provided in full length. Transverse reinforcement shall not be less than 6 mm diameter at a spacing of not more than the stem diameter or 300 mm, whichever is less. In under-reamed compaction piles, a minimum number of four 12-mm diameter bars shall be provided. For piles of lengths exceeding 5 m and of 375 mm diameter, a minimum number of six 12-mm bars shall be provided. For piles exceeding 400 mm diameter, a minimum number of six 12-mm bars shall be provided. The circular stirrups for piles of lengths exceeding 5 m and diameter exceeding 375 mm shall be minimum 8-mm diameter bars.

The minimum clear cover over the longitudinal reinforcement shall be 40 mm. In aggressive

environment of sulphates, etc, it may be increased to 75 mm.

Figure 6.9 gives typical details of a bored cast-in-situ under-reamed pile foundation.

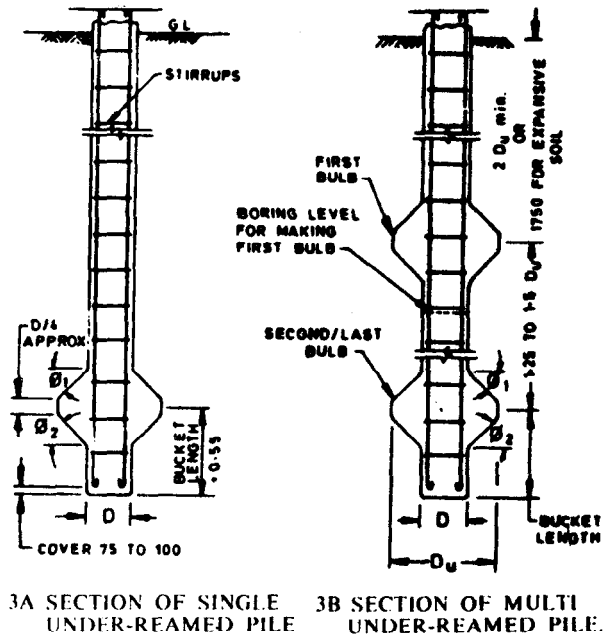

3A SECTION OF SINGLE UNDER-REAMED PILE 3B SECTION OF MULTI UNDER-REAMED PILE.
 $\phi_1 = 45^\circ$ (approx), $\phi_2 = 30^\circ-45^\circ$ (Approx)
 $D_u =$ normally $2.5D$

FIG. 6.9 TYPICAL DETAILS OF BORED CAST *in-situ* UNDER-REAMED PILE FOUNDATION

6.9.4 Pile Caps

6.9.4.1 The pile cap usually supports column and this is positioned at the centre of gravity of the pile group, so the pile cap incorporates column dowel bars in exactly the same way as provided in column bases. Allowance shall be made in length and width of the cap to allow for piles being slightly out of true position after being driven.

6.9.4.2 General consideration — The pile cap alongwith the column pedestal shall be deep enough to allow for the necessary anchorage of the column and pile reinforcement. Although they are assumed to act as a simply supported beam and are designed for the usual conditions of bending moment and shear force, there is a tendency to fail in bursting due to high principal tension. This should be resisted by reinforcement going around outer piles in the group (usually # 12 @ 150).

Generally adopted configuration for pile caps alongwith plan arrangement of reinforcement details are shown in Fig. 6.10.

6.9.4.3 The clear overhang of the pile cap beyond the outermost pile in the group shall normally be 100 to 150 mm, depending upon the pile size.

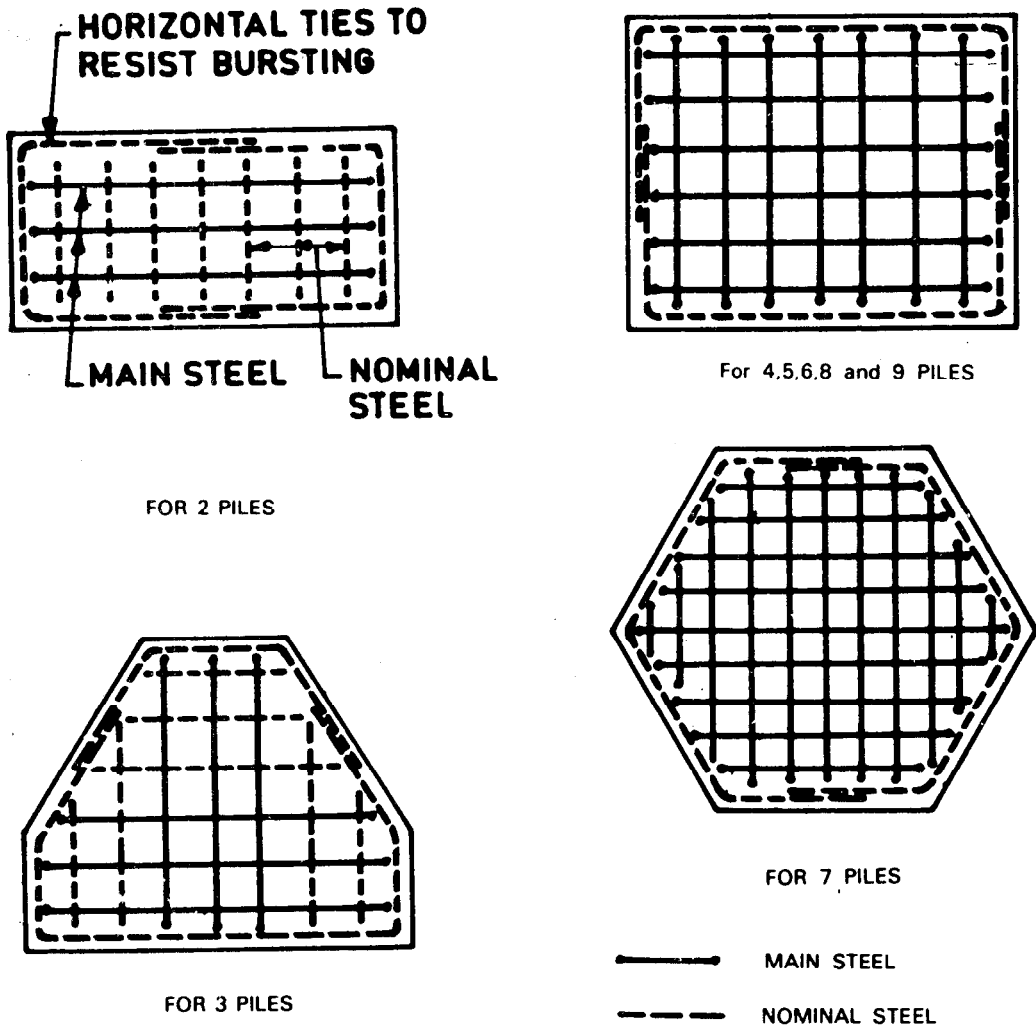

FIG. 6.10 GENERALLY ADOPTED CONFIGURATION FOR PILE CAPS (ALONG WITH PLAN ARRANGEMENT OF REINFORCEMENT)

6.9.4.4 A levelling course of plain concrete of about 80 mm thickness may be provided under the pile caps, as required.

6.9.4.5 The clear cover for the main reinforcement for the bottom of cap shall not be less than 60 mm.

6.9.4.6 The reinforcement from the pile should be properly tied to the pile cap.

6.9.4.7 A typical arrangement of bars in a pile cap supporting a column between two piles is illustrated in Fig. 6.11 and typical details of a pile cap resting on 3 piles is illustrated in Fig. 6.12.

6.9.5 Grade Beams

6.9.5.1 The grade beams supporting the walls shall be designed taking due account of arching effect due to masonry above the beam. The beam with masonry behaves as a deep beam due to composite action.

6.9.5.2 The minimum overall depth of grade beams shall be 150 mm. The reinforcement at the bottom should be kept continuous and an equal amount may be provided at top to a distance of quarter span both ways from pile or footing centres as the case may be. The longitudinal reinforcement both at top and bottom should not be less than three bars of 10 mm diameter (mild steel) and stirrups of 6 mm diameter bars spaced at a maximum spacing of 300 mm (see Fig. 6.13).

6.9.5.3 In expansive soils, the grade beams shall be kept a minimum of 80 mm clear off the ground. In other soils, beams may rest on ground over a levelling concrete course of about 80 mm (see Fig. 6.14).

6.9.5.4 In case of exterior beams over piles in expansive soils, a ledge projection of 75 mm thickness and extending 80 mm into ground (see Fig. 6.14), shall be provided on outer side of beams.

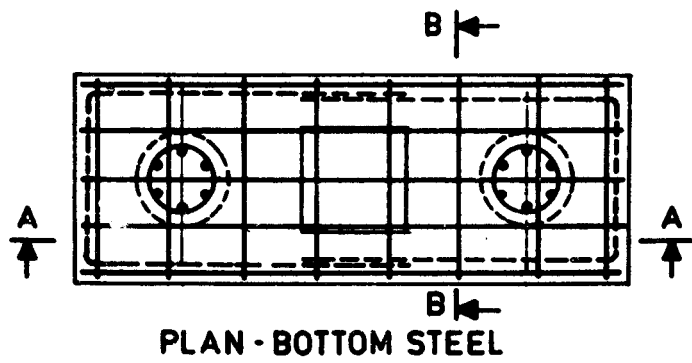
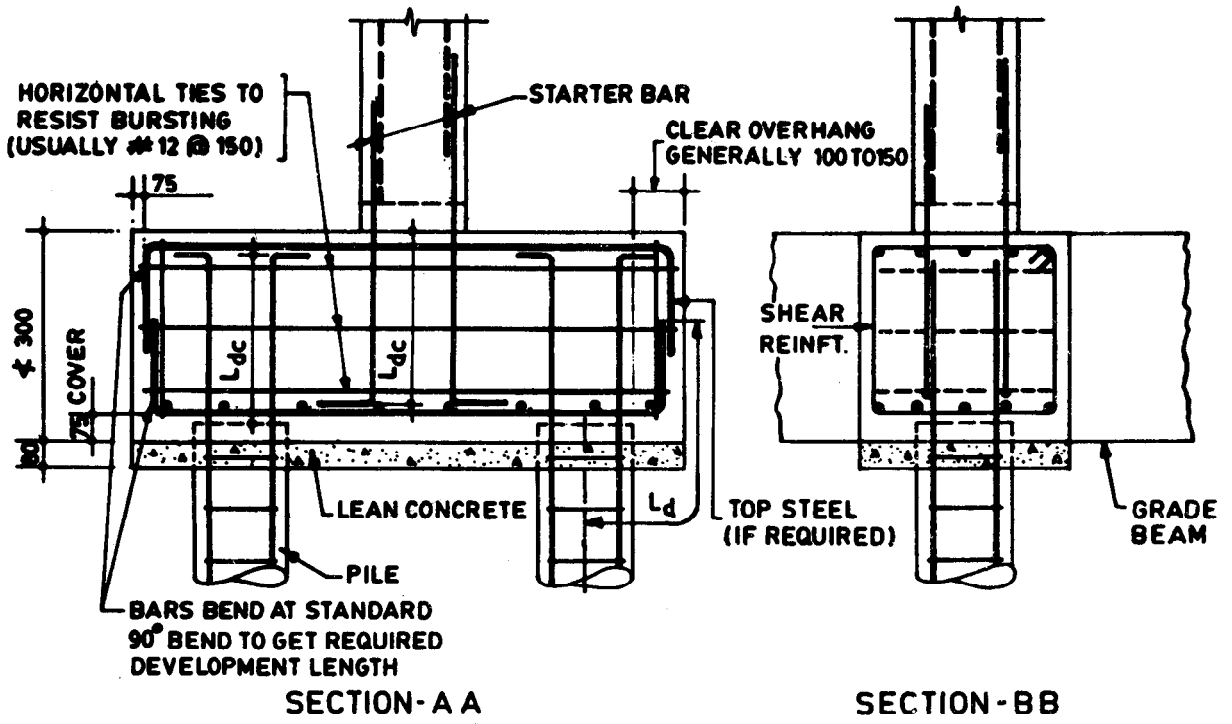

NOTE — In a 2-pile system, sufficient care should be taken to transfer bending in the transverse direction.
 FIG. 6.11 TYPICAL DETAILS OF A 2-PILE CAP

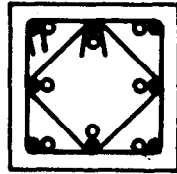

SECTION-BB

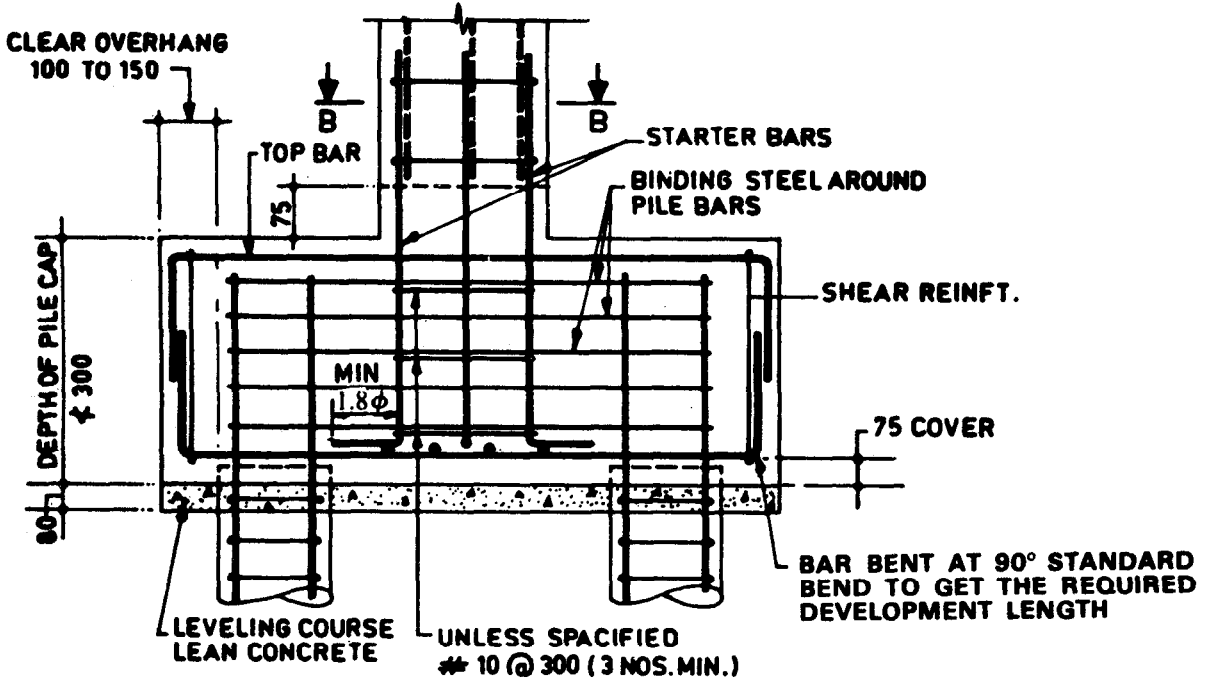

SECTION-A A

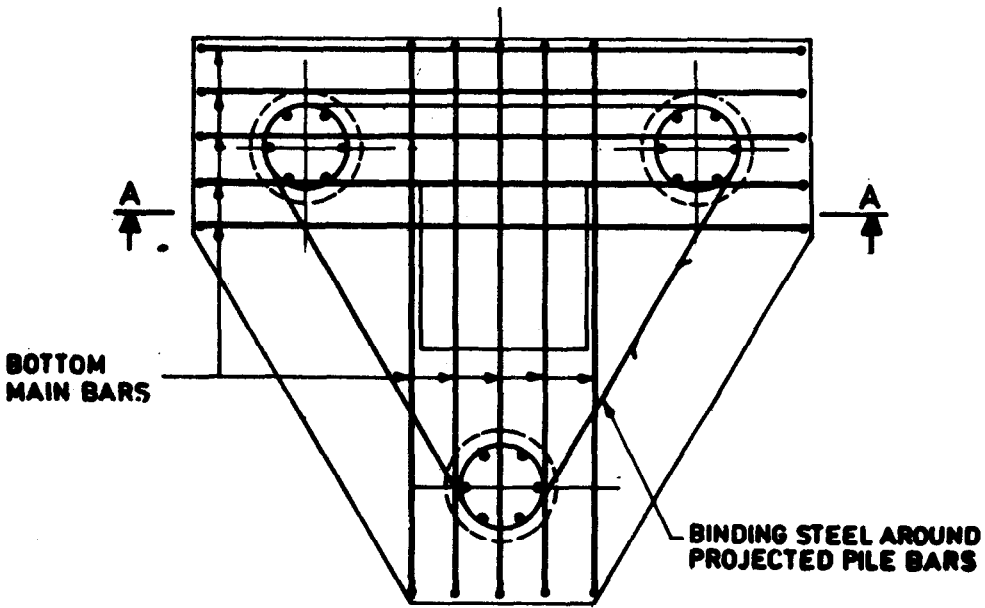

PLAN

FIG. 6.12 TYPICAL DETAILS OF A 3-PILE CAP

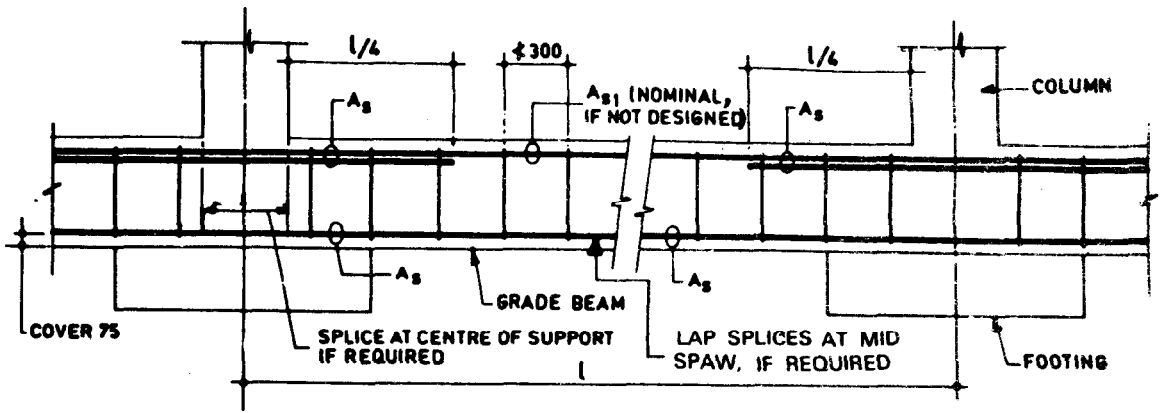
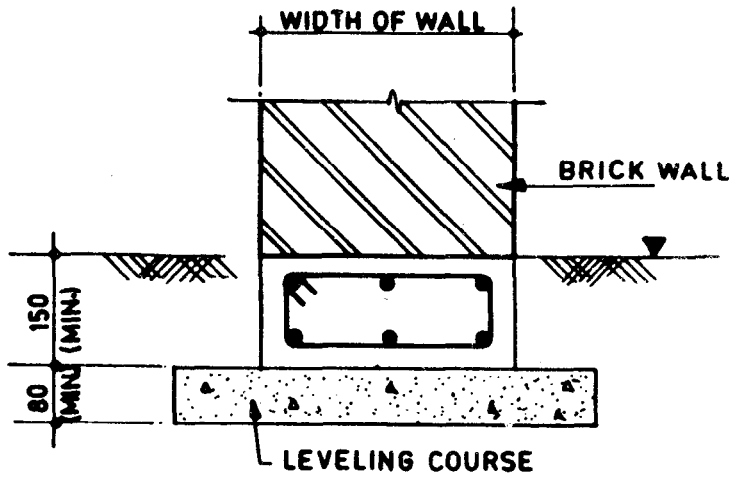
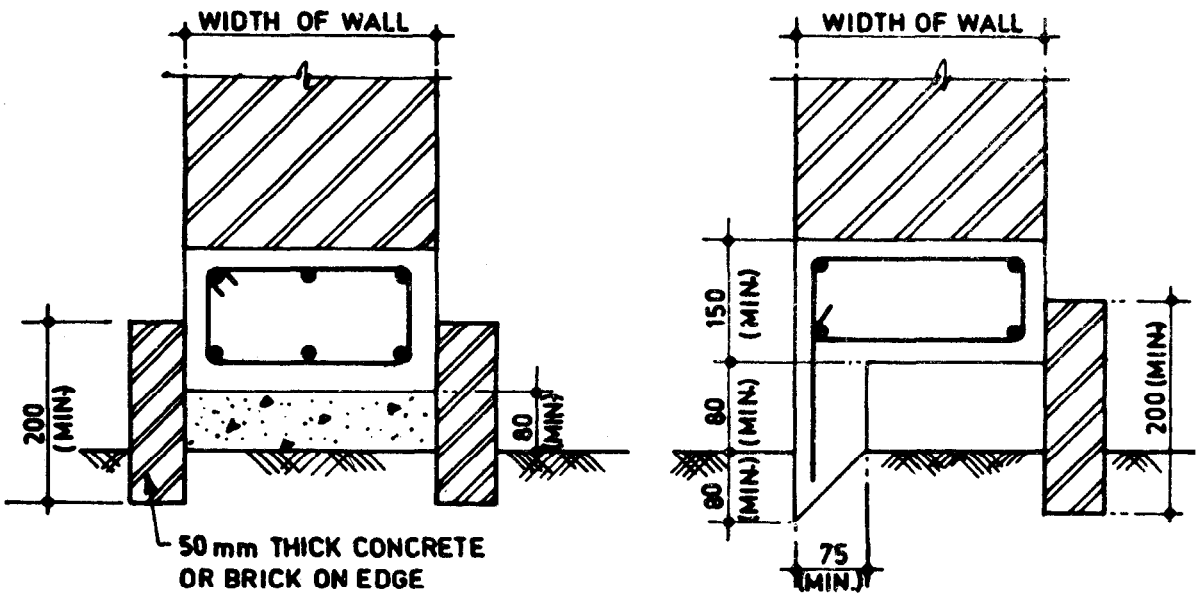

FIG. 6.13 TYPICAL LONGITUDINAL SECTION OF A GRADE BEAM



6.14A BEAMS IN NON-EXPANSIVE SOILS



6.14B BEAMS IN EXPANSIVE SOILS

FIG. 6.14 TYPICAL SECTIONS OF GRADE BEAMS

SECTION 7
Columns

SECTION 7

COLUMNS

7.0 General— Reinforced concrete columns are used to transfer the load of the structure to its foundations. These are reinforced by means of main longitudinal bars to resist compression and/or bending; and transverse steel (ties) to resist bursting force.

The column or strut is a vertical compression member, the effective length of which exceeds three times its least lateral dimension.

7.1 Longitudinal Reinforcement

7.1.1 In a reinforced column, the area of longitudinal reinforcement shall not be less than 0.8 percent nor more than 6 percent of the gross cross-sectional area of the column.

The area of longitudinal reinforcement should normally not exceed 4 percent of the gross cross-sectional area of the column. This percentage can be considered as the maximum from practical considerations.

However where bars from one column have to be lapped with those of another column above, the total maximum percentage of 6 percent may be allowed at the lapping. Proper placing and compacting of concrete should be ensured at the place of lapping.

7.1.2 A minimum number of 4 bars shall be provided in a column and six bars in a circular column with helical reinforcement.

7.1.3 The bars shall be not less than 12 mm in diameter and spacing of the bars along the periphery of the column shall not exceed 300 mm.

7.1.4 In the case of pedestals in which the longitudinal reinforcement is not taken into account in strength calculations, nominal longitudinal reinforcement of not less than 0.15 percent of the gross cross-sectional area shall be provided.

NOTE— Pedestal is a compression member, the effective length of which does not exceed 3 times the least lateral dimension.

7.1.5 Dowels and Bar Supports— Dowels and bar supports, spacer bars, bar chairs, etc. should be specifically listed on the structural drawing and should be scheduled in that portion of the structure in which they are first required so that they can be delivered with reinforcement and are available for placement in time. Footing dowels shall be scheduled with footings rather than in column schedules (see Section 6 for requirements of dowels in footing).

7.2 Transverse Reinforcement

7.2.1 A reinforcement concrete compression member shall have transverse or helical reinforcement so disposed that every longitudinal bar nearest to the compression face has effective lateral support against buckling. The effective lateral support is given by transverse reinforcement either in the form of circular rings capable of taking up circumferential tension or by polygonal links (lateral ties) with internal angle not exceeding 135° .

7.2.2 Arrangement of Transverse Reinforcement— Where the longitudinal bars are not spaced more than 75 mm on either side, transverse reinforcement need only to go round corner and alternate bars for the purpose of providing effective supports (see Fig. 7.1).

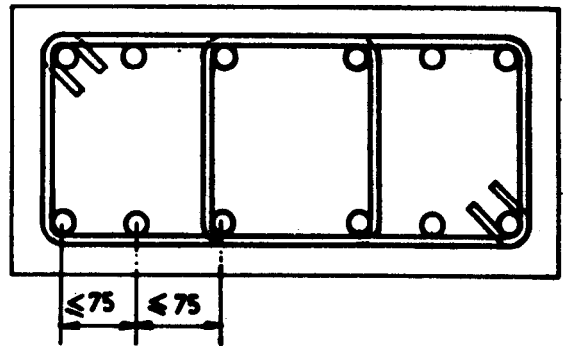

FIG. 7.1

7.2.3 If the longitudinal bars spaced at a distance not exceeding 48 times the diameter of the tie are effectively tied in two directions, additional longitudinal bars in between these bars should be tied in one direction by open ties (see Fig. 7.2).

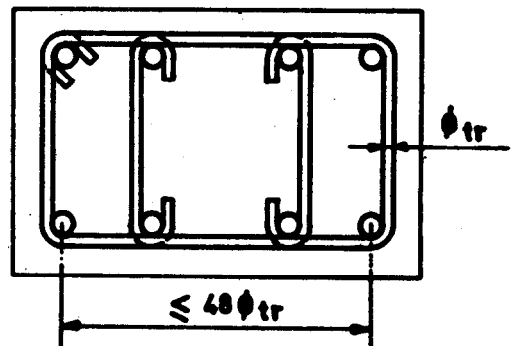
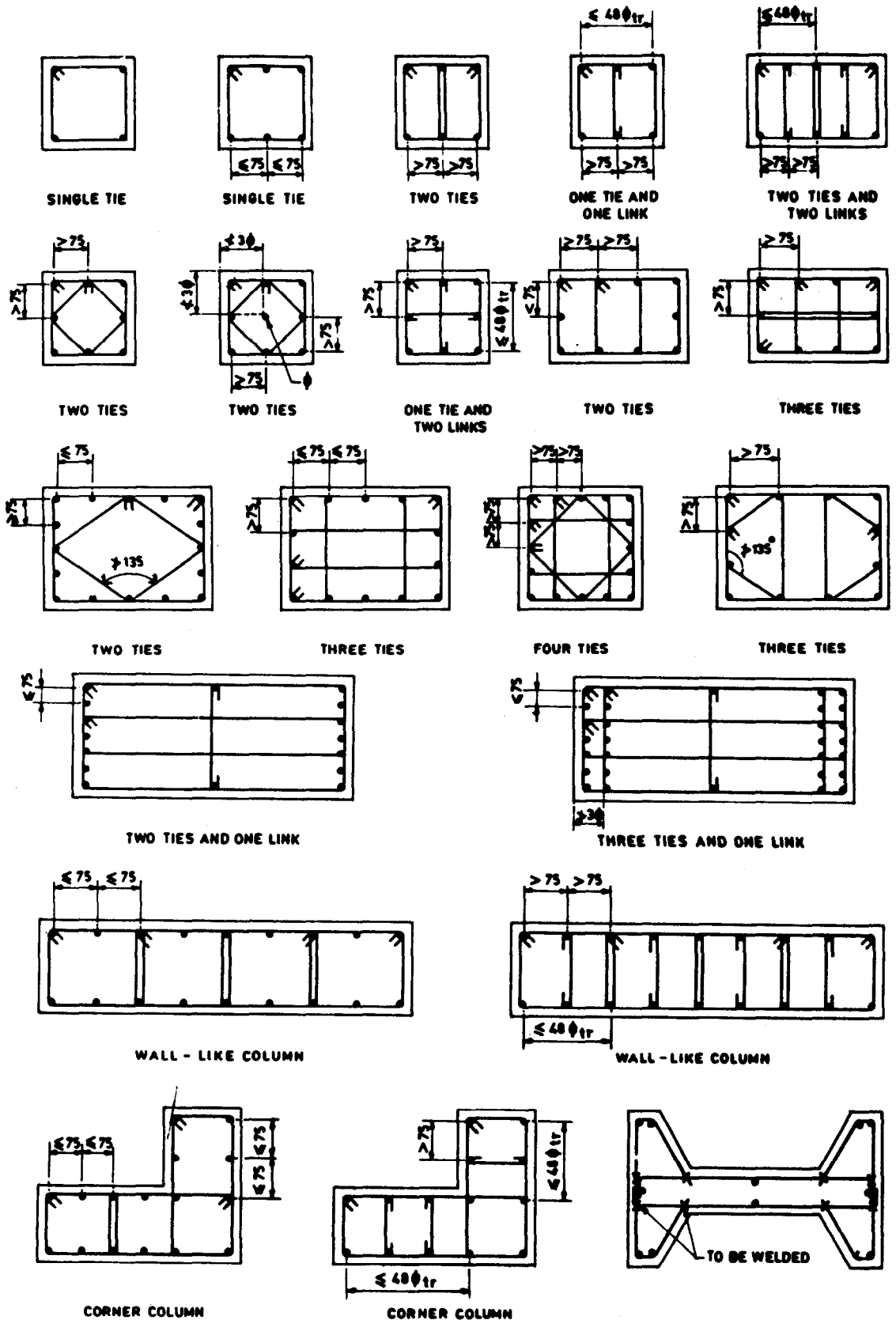
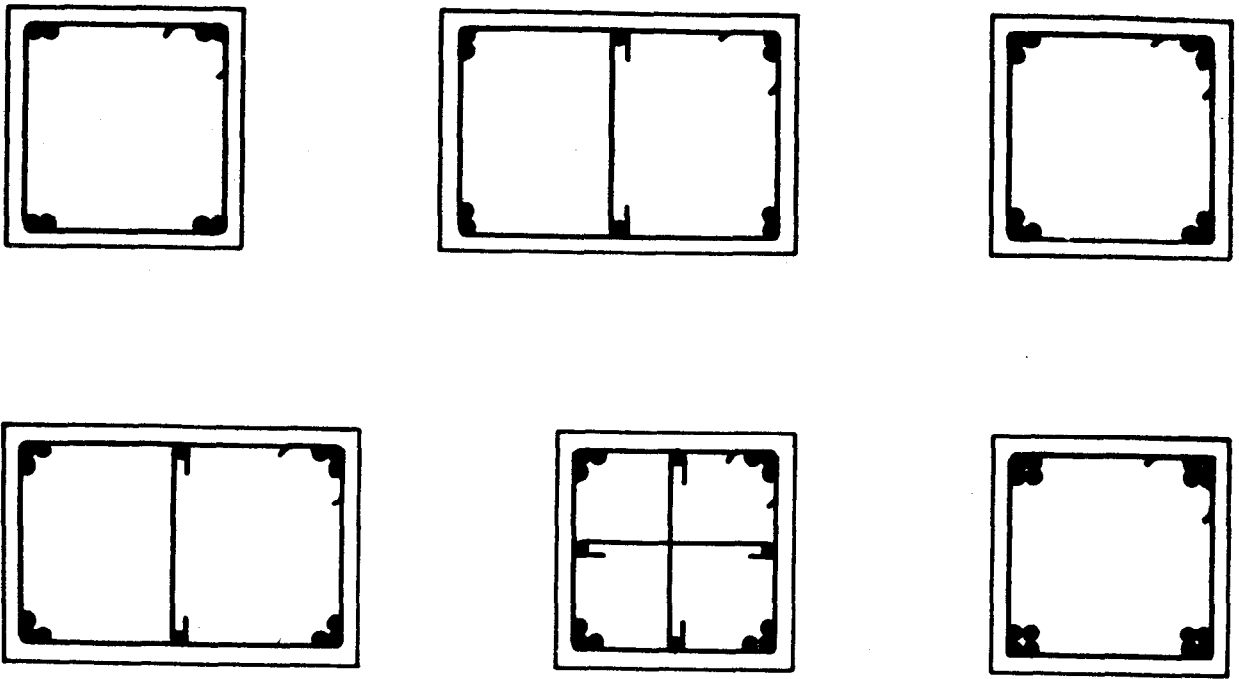

FIG. 7.2



7.5A LATERAL TIES AND LINKS

FIG. 7.5 TYPICAL ARRANGEMENT OF COLUMN TIES (Continued)



7.5B EXAMPLES OF ARRANGING BUNDLE BARS IN COLUMNS

FIG. 7.5 TYPICAL ARRANGEMENT OF COLUMN TIES

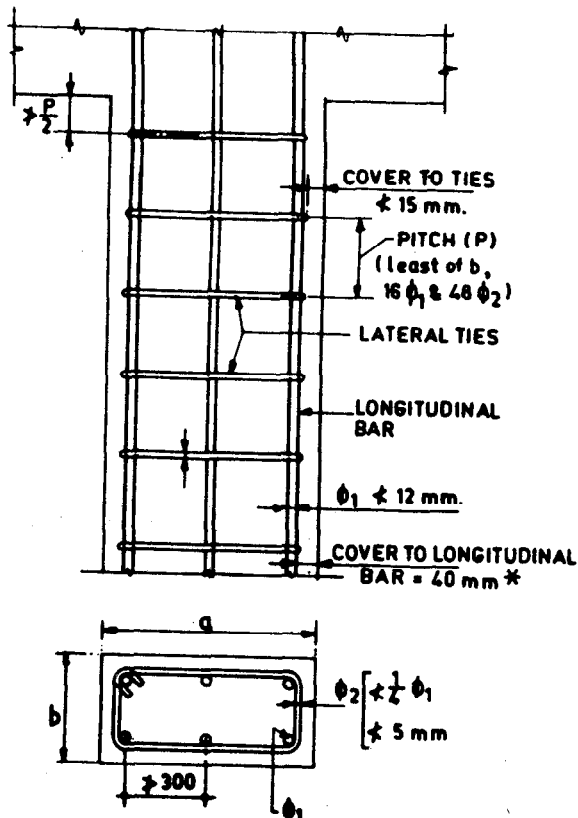

7.6A RECTANGULAR COLUMN

*Cover can be reduced to 25mm when $a \nless 200$, $b \nless 200$ and $\phi = 12$.

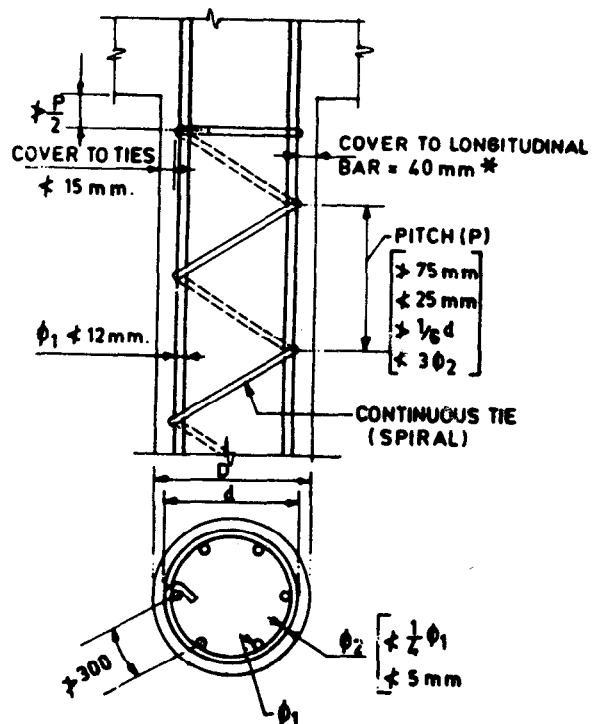

7.6B CIRCULAR COLUMN

*Cover can be reduced to 25 mm when $D \nless 200$ and $\phi = 12$

FIG. 7.6 BAR SPACING REQUIREMENTS IN COLUMNS

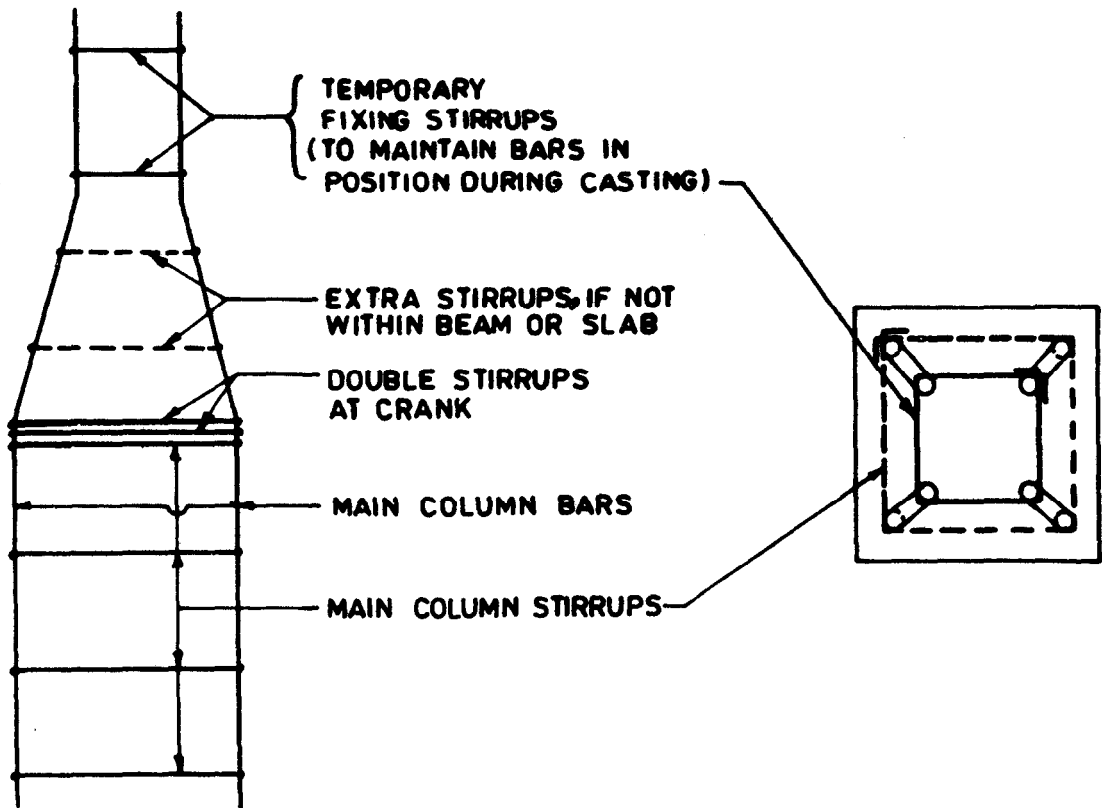

FIG. 7.7 TEMPORARY FIXING OF STIRRUPS

7.2.9 Large Columns — Where reinforcement for very wide columns is to be fabricated in separate cages and erected in sections, they should be held together by at least 12 mm diameter bars spaced at double the stirrup spacing (see Fig. 7.8). Special requirements, if any, should be indicated by the designer.

7.3 Splicing of Column Reinforcement

7.3.1 General — Splicing is normally effected by the lapping of bars. The lengths of laps in the main bars shall conform to the values given in Section 4 (Tables 4.2 to 4.4). The bottom of the bars are normally at floor level. In exceptional cases, the bars may extend over more than one storey, provided that check is made to ensure that intersecting steel from beams, etc, can be placed through the column without difficulty, that the column reinforcement can be properly supported, and the concrete can be properly placed. Some of the bars terminating below floor level require separate splicing (see also Section 4). Typical splice details are shown in Fig. 7.9 (A to E) for both internal and external columns.

7.3.2 Where a column at a particular floor is smaller (in cross-section) than the column immediately below it, the vertical bars from the

lower column shall be offset to come within the upper column, or dowel shall be used. The slope of the inclined portion shall not exceed 1 in 6. In detailing offset column bars, a bar diameter should be added to the desired offset; and in the corner of the square columns, the bars should be offset along the diagonal.

7.3.3 Longitudinal reinforcement bars in square or rectangular columns should be offset bent into the column above. Longitudinal bars in round columns where the column size is not changed should be offset bent if maximum number of bars are desired in the column above. The general practice is to sketch the offset for the corner bars which should be bent diagonally and make this the typical offset dimension for all the bars in the column.

7.3.4 For offset between column faces up to a maximum of 75 mm, the longitudinal bars should be offset bent. When the offset exceeds 75 mm, the longitudinal bars in the column below should be terminated at the floor slab and separate dowels used (see Fig. 7.9B and 7.9D).

7.3.5 Where adjoining beam is not provided, the height of the column equal to say 75 mm above the floor level should be cast along with the lower column so that a kicker can be formed to place the column shutters (see Fig. 7.9C).

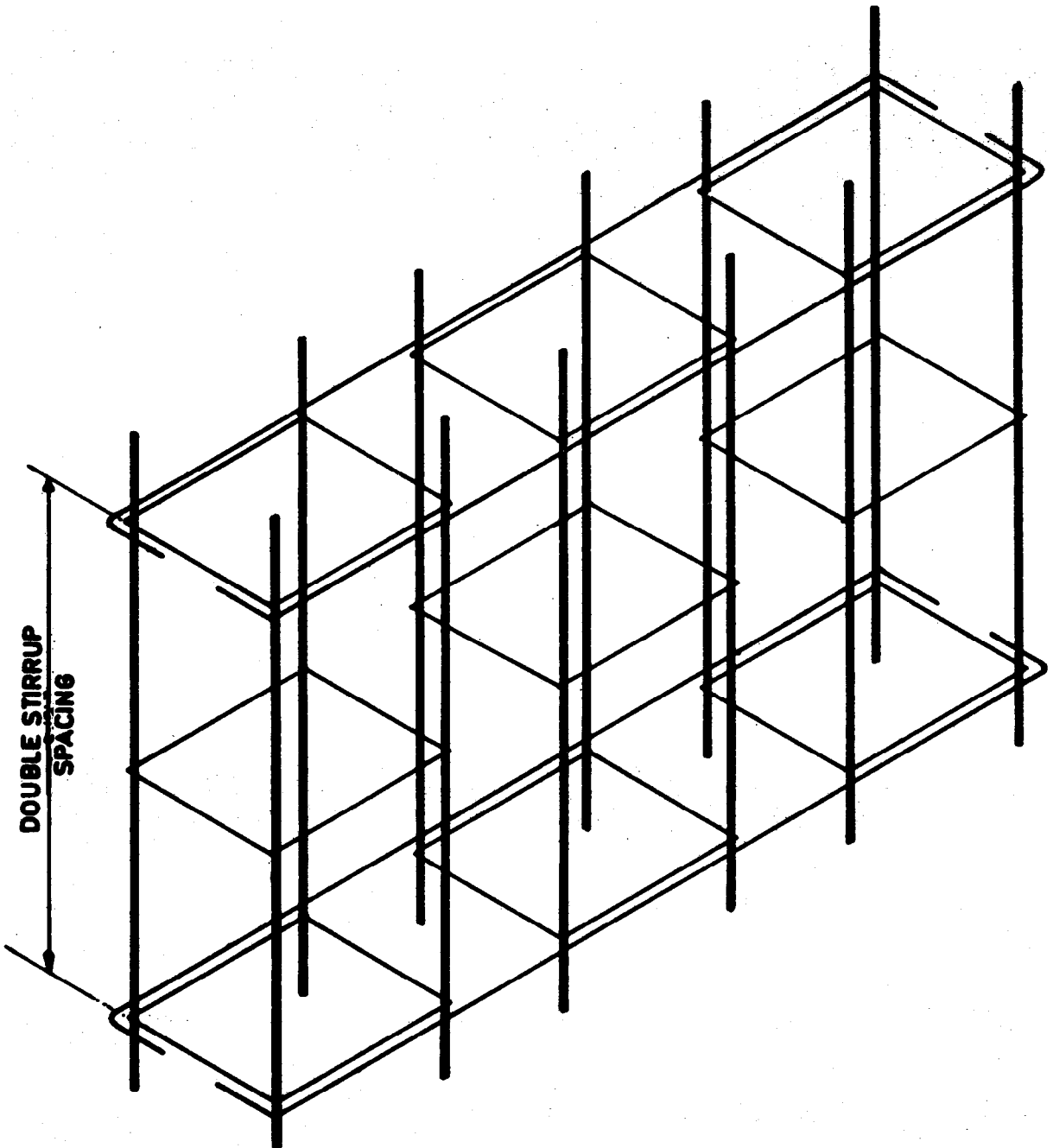
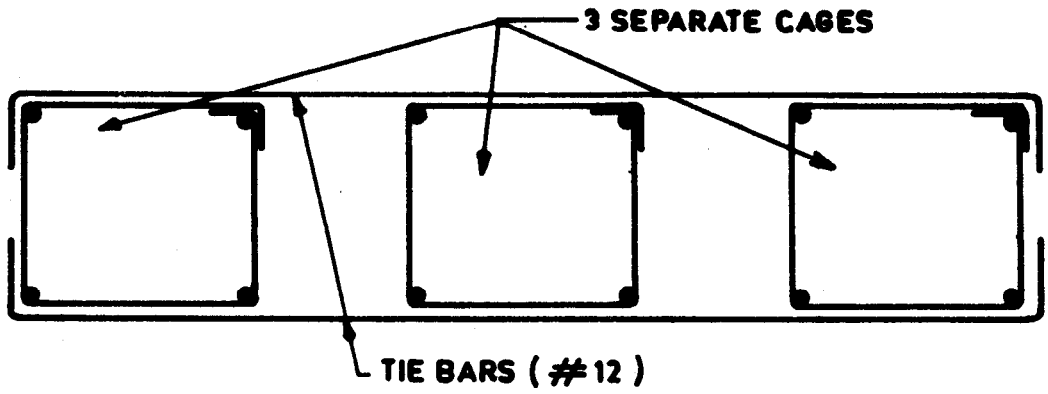
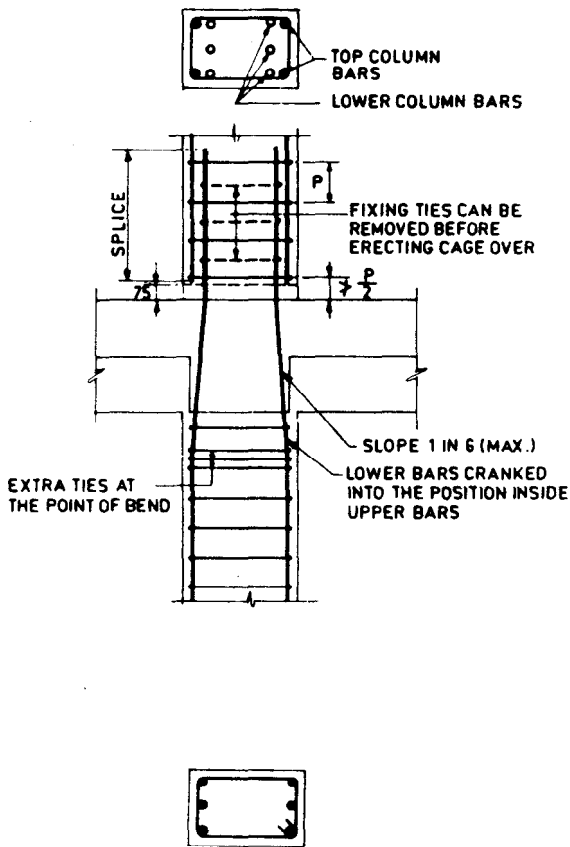
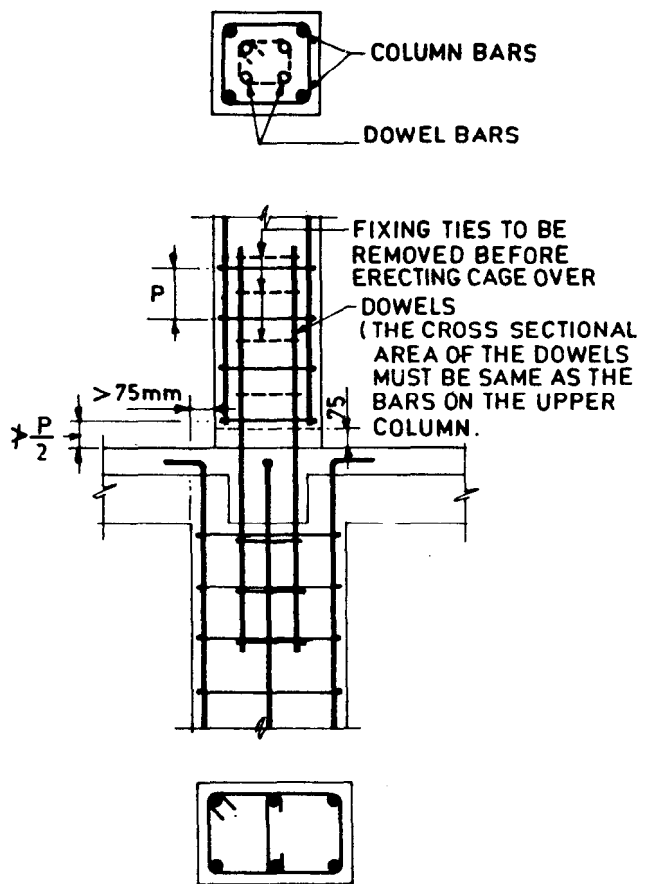

FIG. 7.8 REINFORCEMENT IN CAGES FOR LONG COLUMNS



7.9A SPLICE WITH LOWER BARS CRANKED INTO POSITION INSIDE UPPER BARS (INTERMEDIATE FLOOR)



7.9B SPLICING AT THE FLOOR LEVEL WHEN THE RELATIVE DISPLACEMENT OF COLUMN FACES IS MORE THAN 75 MM

7.3.6 When the bar arrangement changes between floors, bars may extend through, stop off, or require separate dowels (Fig. 7.9B). Each situation requires its own solution. Steel equal to an area and bond capacity to that in the column above shall be extended. Column bars shall be spliced at the top of upstand beams, if available, rather than at floor level.

7.3.7 Where the column verticals are offset bent, additional ties/spirals shall be provided (see Fig. 7.10) and placed at a distance not more than 8 bar diameters from the point of the bend. For practical purpose, 3 closely spaced ties are usually used, one of which may be part of the regularly spaced ties plus two extra ties. The designer shall indicate on the drawing the general arrangement of vertical bars and all tie arrangements.

The number of additional ties/spirals should be designed on the assumption that the horizontal thrust to be resisted shall be 1.5 times the horizontal components of the normal stress in the inclined portion of the bars.

7.3.8 Welded splice or other positive connections may be used as butt splices for

vertical column bars instead of lapped splices. For bars of size 32 mm and above, such splices or connections may be used to avoid overcrowding of the bars due to extremely long laps which would otherwise be required. Special preparation of the ends of the vertical bars is usually required. Where bars are welded, the most common practice is to provide a square-cut end at the top and a double bevelled end on the bottom of the upper bar to rest on the square cut end (see Fig. 7.11). This permits filling the resulting space with weld metal to develop the splice. Where a welded sleeve or a mechanical device is used, both ends of the bar may be either square cut or standard shear cut, depending upon the type of connection used. Since the point of splice is to be staggered between alternate vertical bars and the splice location will depend upon the design requirements, the designer should indicate the types of splice permissible and their location on the drawing.

7.4 Bundled bars shall be tied, wired or otherwise fastened to ensure that they remain in position. End-bearing compression splices should

be held concentric, all bundles of column verticals should be held by additional ties at each end of end-bearing splices, and any short splice bars added for tension should be tied as part of the bundle within the limit of 4 bars in a bundle. A corner of a tie should be provided at each bundle.

7.5 Column in Flat Slabs — Mushroom heads are normally cast with the columns, and the details of reinforcement should be such that the steel can be formed into a separate cage. Therefore, it should be ensured that the column stirrups end below the mushroom head to enable a properly bonded cage to be positioned (see Fig. 7.12).

NOTE — The designer shall determine the amount of steel required in the mushroom to control cracks arising from the out-of-balance moments.

7.6 Column-Beam Junction — Typical details of a column-beam junction are illustrated in Fig. 7.13.

At column-beam intersections, it is better to avoid main beam bars clashing with main column bars.

If splice bars are used (see Fig. 7.13), the beam cages may be prefabricated and splice bars placed in position after the beam reinforcement has been positioned in place. This also provides considerable scope for positioning support bars without resorting to cranking and avoiding intersecting beam and column reinforcement. However, this detail requires extra steel due to the additional laps.

Where the beam does not frame into the column on all four sides to approximately the full width of the column, ensure that the stirrups are provided in the column for the full depth of the beam, or alternately, that special U-bars are detailed with the beam to restrain the column bars from buckling and to strengthen the concrete in compression. This is especially important where

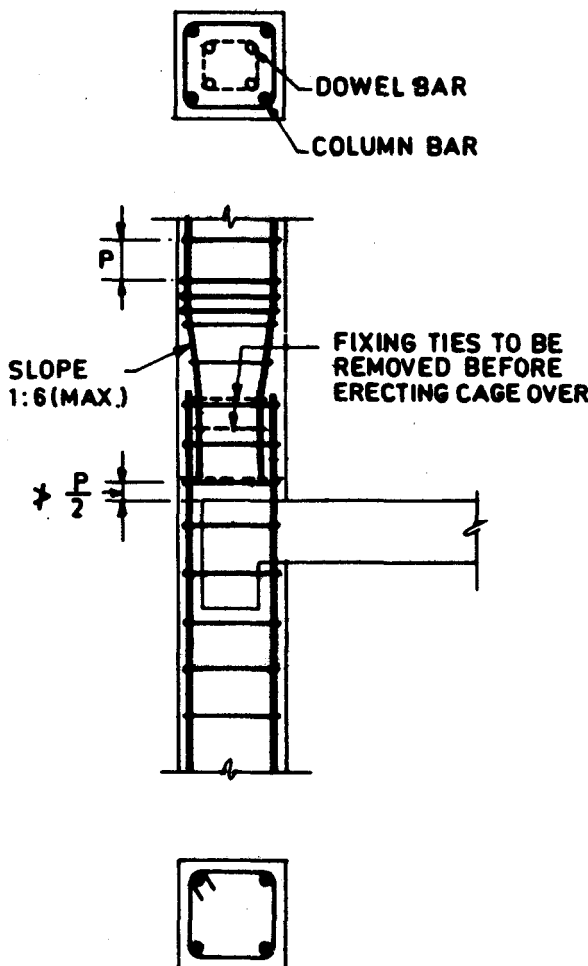

7.9C SPLICE WITH UPPER BARS CRANKED INTO POSITION INSIDE LOWER BARS

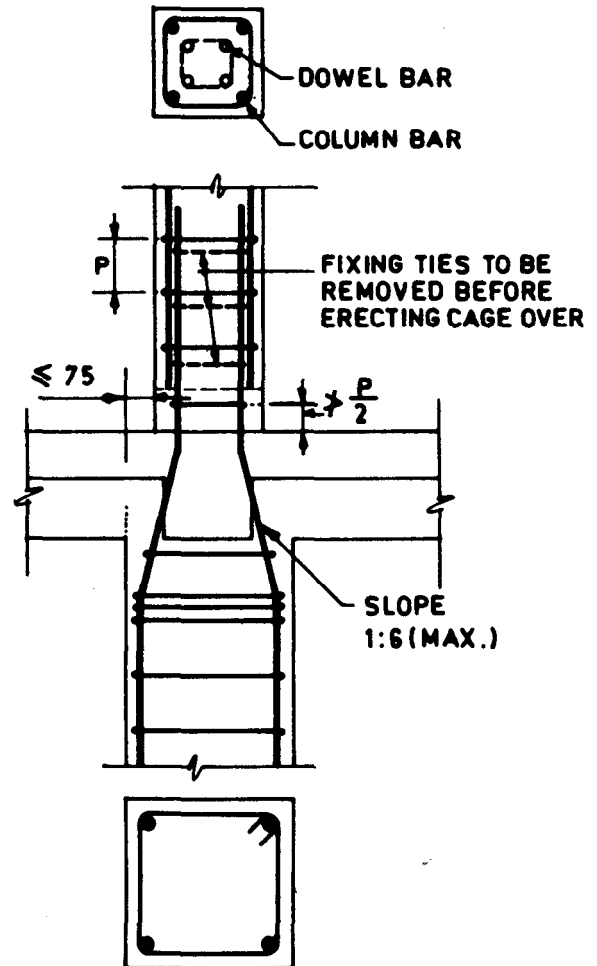

7.9D SPLICE WITH THE LOWER BARS CRANKED INTO A POSITION INSIDE THE UPPER BARS WHEN THE RELATIVE DISPLACEMENT OF COLUMN FACES IS LESS THAN 75 MM

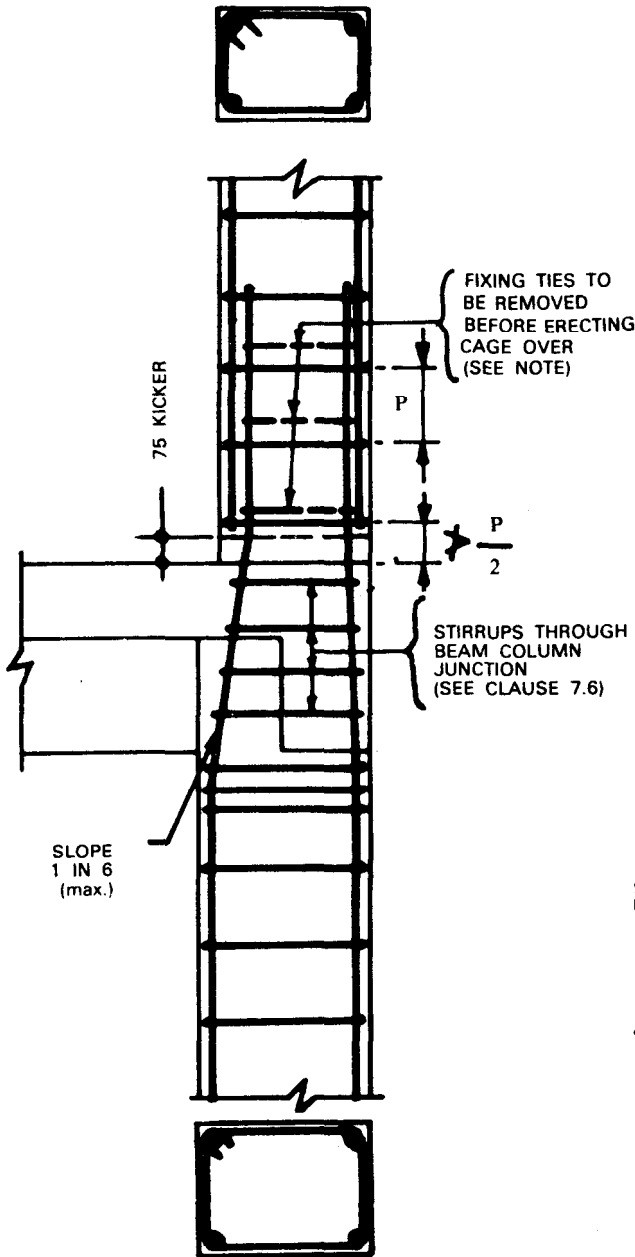

7.9E Splicing when the Lower Bars Cranked into a Position inside the Upper Bars with Stepping of Columns on One Side

NOTE — It is important to note that splices should be staggered within the column

Fig. 7.9 SPlicing OF COLUMN BARS AT INTERMEDIATE FLOORS

the floor concrete is of a weaker grade than the column concrete (see Fig. 7.14 and 7.15).

In general, it is advisable to use U-bars at the non-continuous ends of beams of depth greater than 600 mm.

NOTE — It is important to note that a joint by itself shall have a dependable strength sufficient to resist the most adverse load combinations sustained by the adjoining

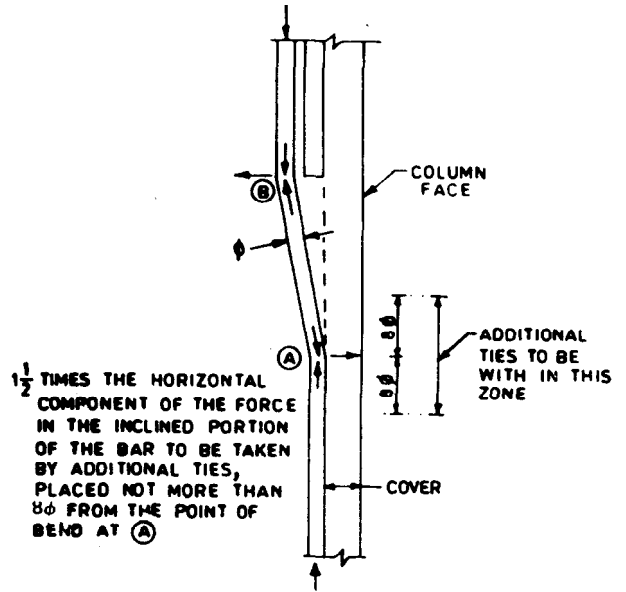

FIG. 7.10 SPLICE WITH OFFSET CRANKED BAR IN A COLUMN

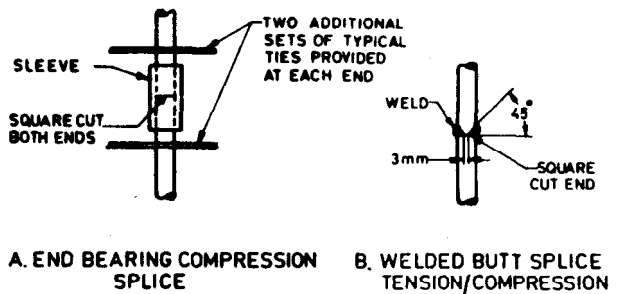

FIG. 7.11 TYPICAL DETAILS OF BUTT SPLICES

members as specified by the appropriate loading code. A higher factor of safety is sometimes necessary for joints. Design and detailing of the joint should be done to satisfy this condition.

7.7 Column with Corbel Joints

7.7.1 Corbels — A corbel is a short cantilever beam (see Fig. 7.16) in which the principal load is applied in such a way that the distance between the line of action of the load and the face of the supporting member is less than $0.6d$ and the depth at the outer face of the bearing is greater than one-half of the effective depth at the face of the supporting member.

7.7.2 Main Reinforcement — The main tension reinforcement in a corbel should be not less than 0.4 percent and not more than 1.3 percent of the section at the face of the supporting member, and should be adequately anchored.

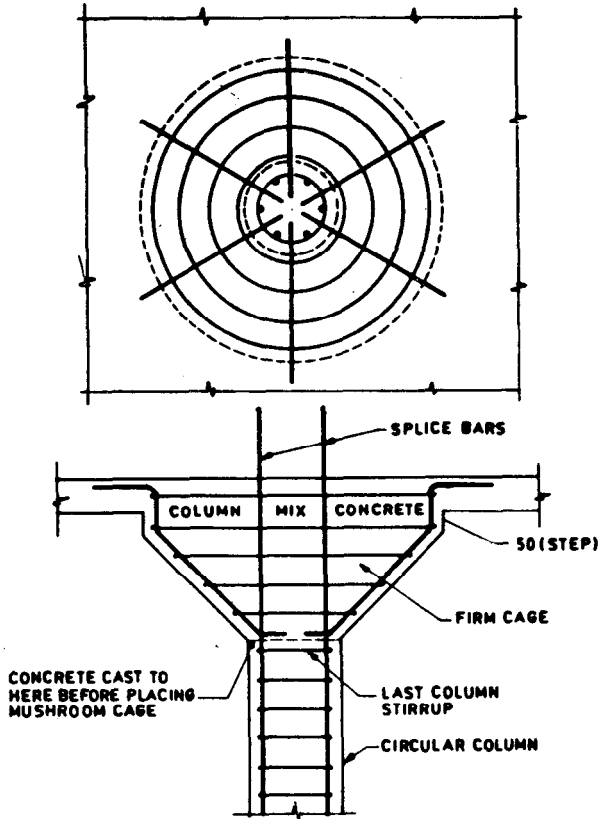

FIG. 7.12 REINFORCEMENT OF MUSHROOM HEADS

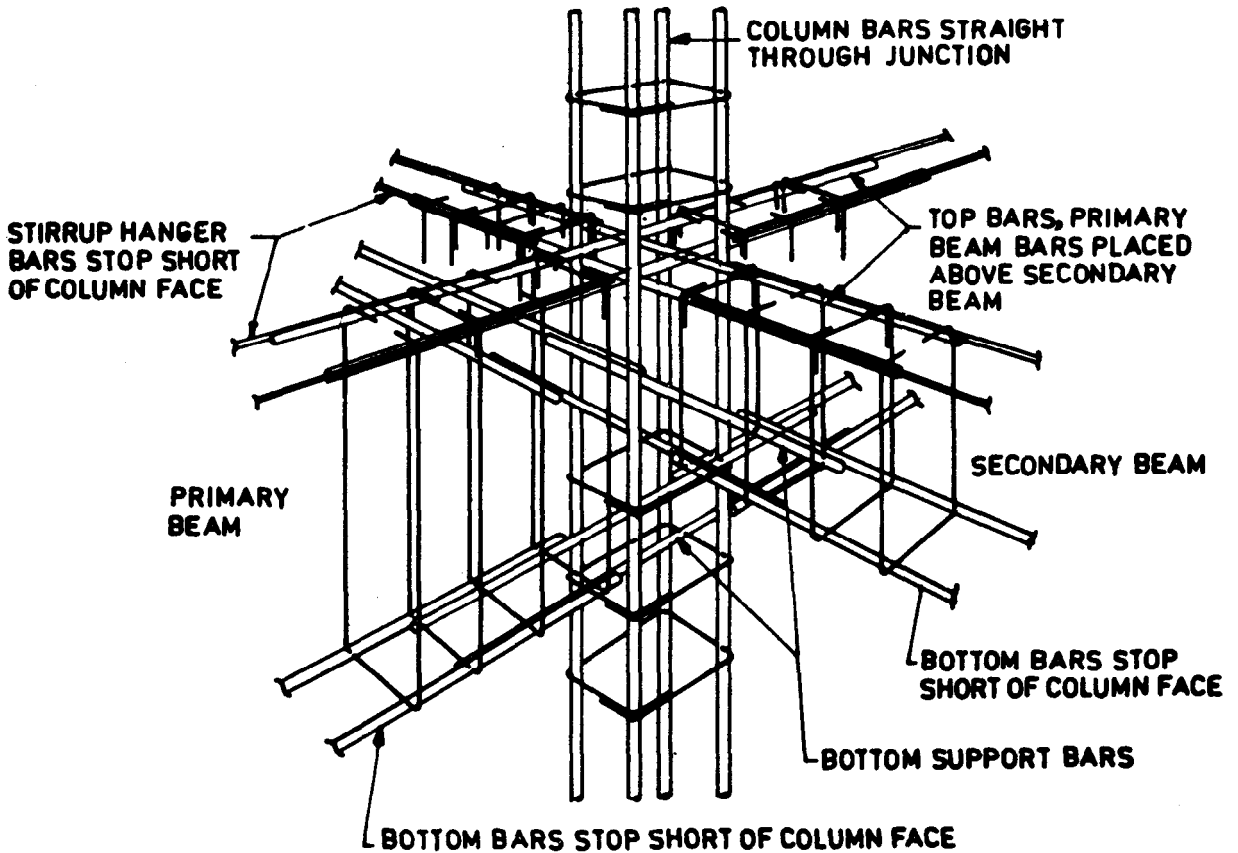
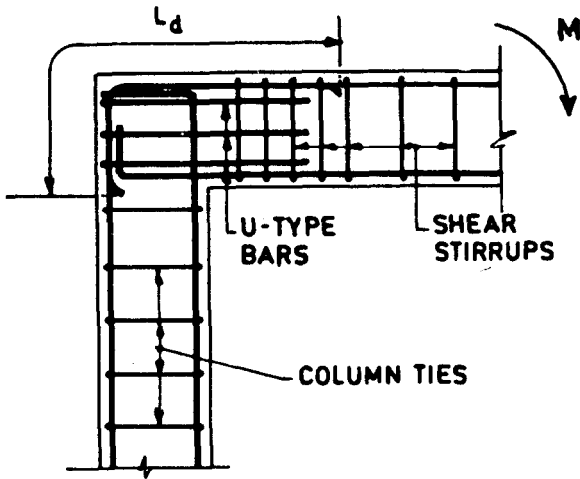

FIG. 7.13 BEAM-COLUMN INTERSECTION



7.14A FIXED END JOINT IN A COLUMN

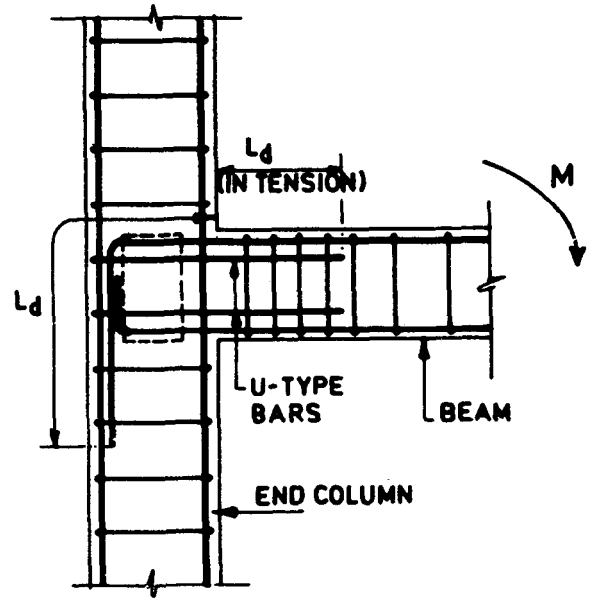
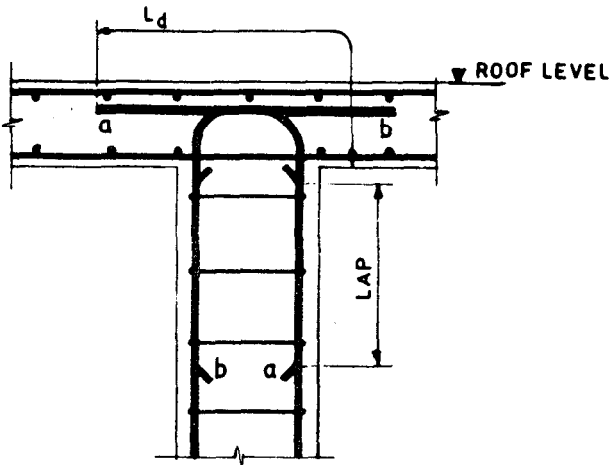

FIG. 7.15 TYPICAL DETAILS OF A BEAM-COLUMN JUNCTION AT EXTERIOR COLUMN



7.14B TERMINATION OF COLUMN BARS INSIDE A SLAB

Fig. 7.14 TYPICAL DETAILS OF END JOINTS IN A COLUMN

Anchor the reinforcement at the front face of the corbel either by welding it to a transverse bar of equal strength or by bending back the bars to form loops; in either case, the bearing area of the load should not project beyond the straight portion of the bars forming the main tension reinforcement (see Fig. 7.17 and 7.18).

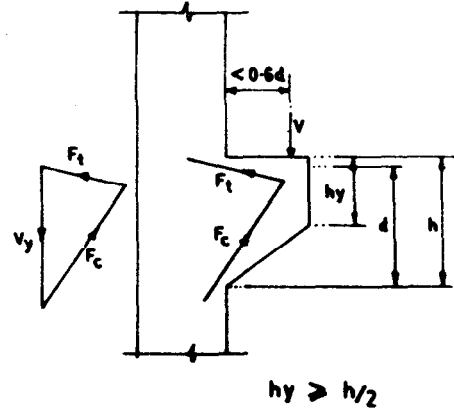

FIG. 7.16 TRUSS ANALOGY FOR CORBEL DESIGN

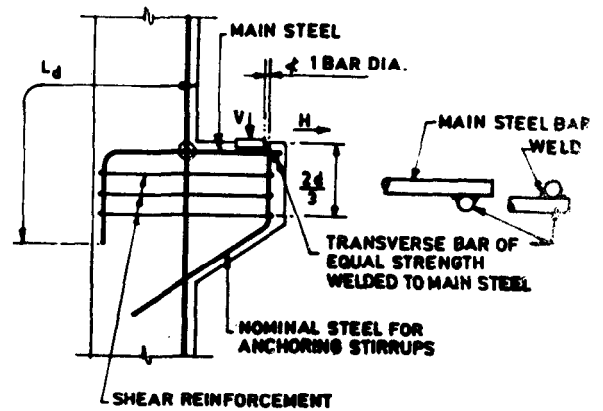

FIG. 7.17

NOTE—The limitation on reinforcement percentages is based on the limited number of tests available.

7.7.3 Horizontal Force—When the corbel is required to resist a horizontal force in direction H applied to the bearing plate (see Fig. 7.19) because of shrinkage or temperature changes, provide additional reinforcement to transmit this force in its entirety. This reinforcement should be welded to the bearing plate and adequately anchored within the supporting member.

7.7.4 Shear Reinforcement—Provide shear reinforcement in the form of horizontal stirrups distributed in the upper two-thirds of the effective depth of the corbel at the column face. This

reinforcement should have an area of at least one-half of the area of the main tension reinforcement and should be adequately anchored (see Fig. 7.19).

7.8 Detailing of Reinforcement—Columns should be detailed by means of enlarged views. Indicate the levels of the bottom (top of bars at floor level) and top of the column (at top of slab or beam or upstand beam) and the floor height, if necessary. Indicate on the schedule the positions of all intermediate beams. Show each bar mark once, and provide adequate sections showing all main bars and the arrangement of stirrups. Keep in view the effect of providing kickers on levels.

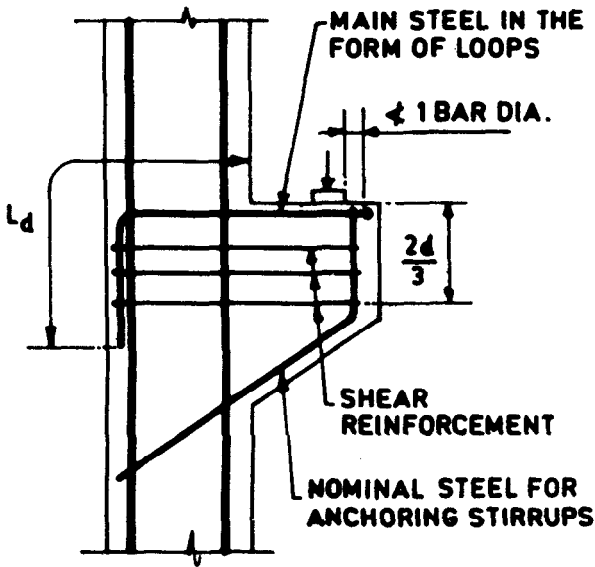

FIG. 7.18

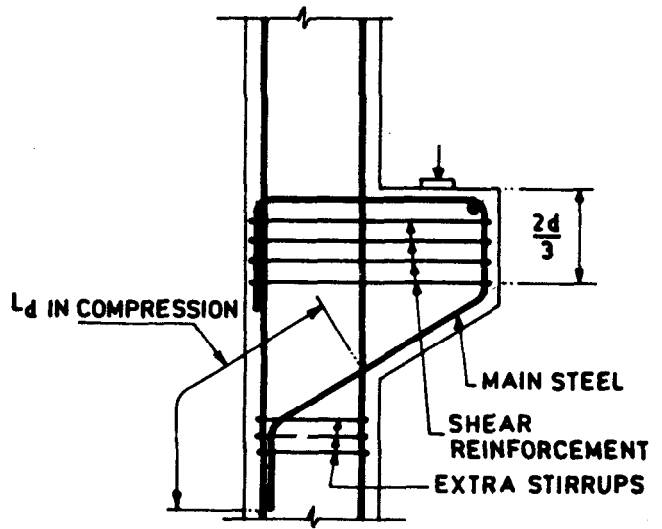

FIG. 7.19

SECTION 8
Beams

SECTION 8

BEAMS

8.1 Arrangement of Bars— The main consideration when arranging bars in beam is to obtain the most economical layout to satisfy the design requirements. It shall also satisfy the relevant rules concerning horizontal and vertical spacing of bars and required bottom and side covers. While fixing the overall dimensions of beams, slenderness limits for beams to ensure lateral stability and span-to-depth ratios to control deflection, shall be kept in view.

The following points shall also be noted in detailing (see Fig. 8.1).

- The bars shall be symmetrically placed about the vertical centre line of the beams.
- Where there are only two bars in a row, these shall be placed at the outer edges.
- Where bars of different diameter are placed in a single bottom row, the larger diameter bars are placed on the outer side.

- Where bars in different horizontal rows have different diameter, the larger diameter bars shall be placed in the bottom row.

8.2 Longitudinal Reinforcement

8.2.1 Minimum Distance Between Individual Bars— The following rule shall apply:

- the horizontal distance between two parallel bars shall be usually not less than the following:
 - diameter of the bar, if the diameters are equal;
 - diameter of the larger bar, if the diameters are unequal; and
 - 5 mm more than the nominal maximum size of coarse aggregate.

NOTE— This does not preclude the use of larger size aggregates beyond the congested reinforcement in the same

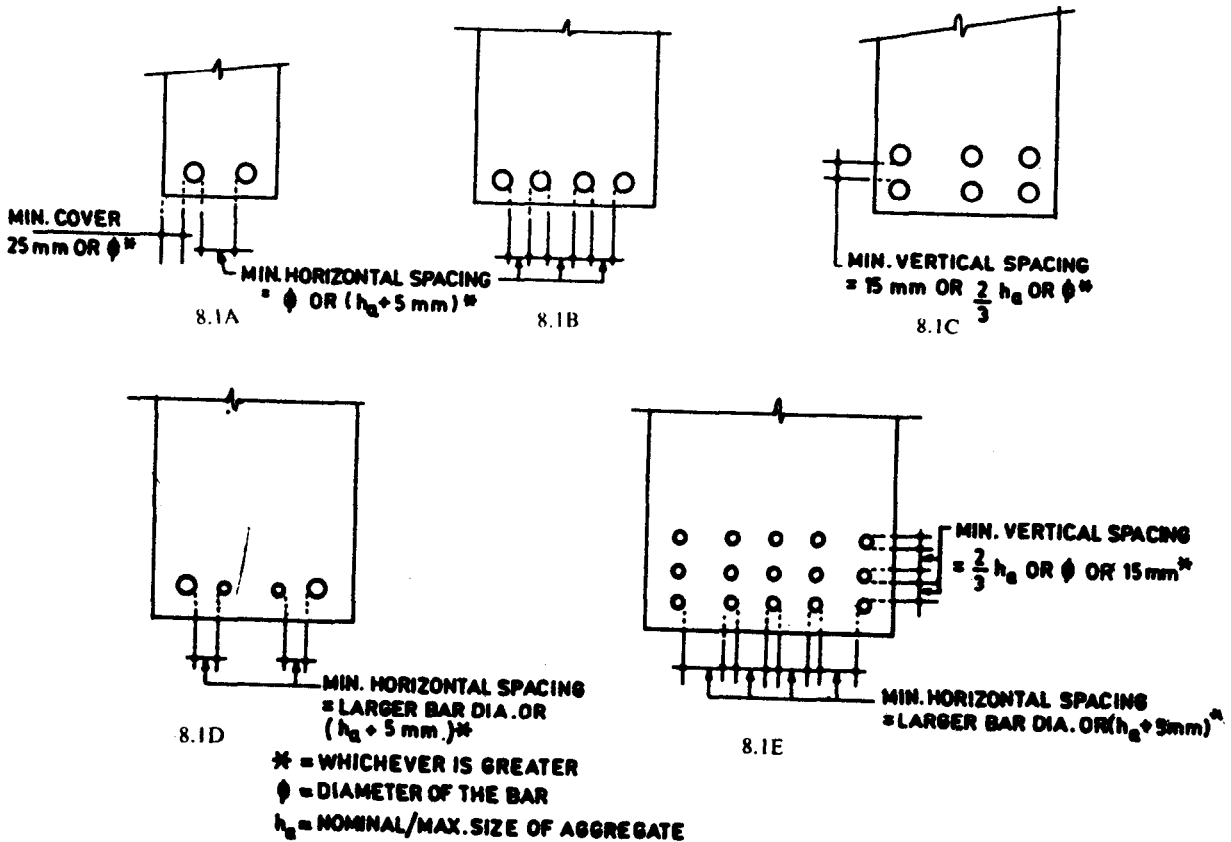

FIG. 8.1 MINIMUM CLEARANCE BETWEEN INDIVIDUAL BARS

member; the size of aggregate may be reduced around congested reinforcement to comply with this provision.

b) Greater horizontal distance than the minimum specified in (a) should be provided, wherever possible. However, when needle vibrators are employed, the horizontal distance between bars of a group may be reduced to two-thirds of the nominal maximum size of aggregate, provided vibrator can be used without difficulty.

c) Where there are two or more rows of bars, the bars shall be vertically in line and the minimum vertical distance between bars shall be 15 mm or two-thirds the nominal maximum size of aggregate or the maximum size of the bar, whichever is the greatest.

The minimum spacing requirements of reinforcing bars in beams is illustrated in Fig. 8.1 and Fig. 8.2.

8.2.2 Tension Reinforcement

8.2.2.1 Minimum reinforcement — The minimum area of tension reinforcement shall not be less than that given by the following:

$$A_s, \text{ Min} = \frac{0.85 \text{ } bd}{f_y}$$

where

- A_s = minimum area of tension reinforcement,
- b = breadth of the beam or the breadth of the web of T-beam,
- d = effective depth, and
- f_y = characteristic strength of reinforcement in N/mm².

8.2.2.2 Maximum reinforcement — The maximum area of tension reinforcement shall not exceed $0.04 \text{ } bD$, where b is the width of the beam rib or web and D is the total depth of the beam.

8.2.2.3 Maximum distance between bars in tension — Unless the calculation of crack widths shows that a greater spacing of bars is acceptable, the following requirement should be fulfilled for control of flexural cracking:

The horizontal distance between parallel reinforcement bars, or groups near tension face of a beam shall not be greater than the value given in Table 8.1 depending on the amount of redistribution carried out in analysis and the characteristic strength of the reinforcement (see Fig. 8.3).

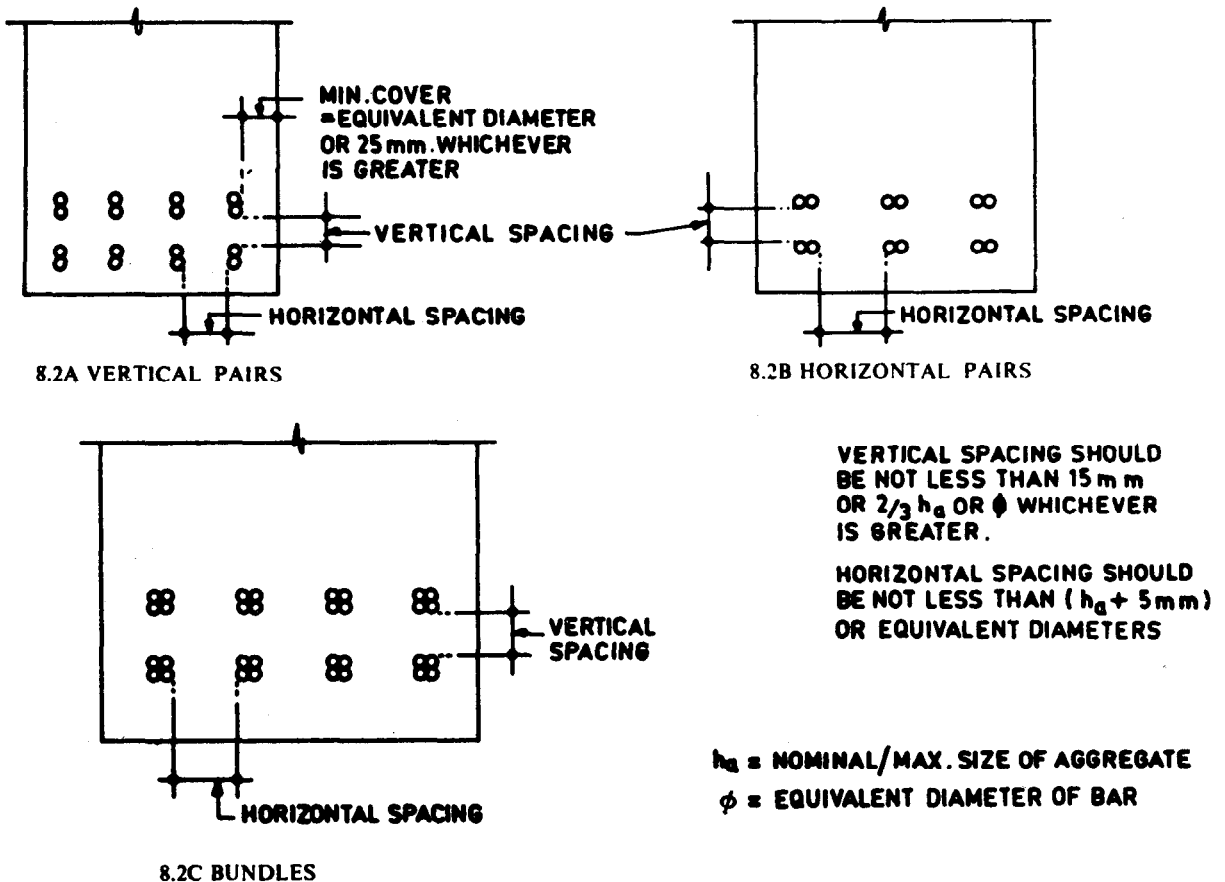

FIG. 8.2 MINIMUM SPACING BETWEEN GROUPS OF BARS

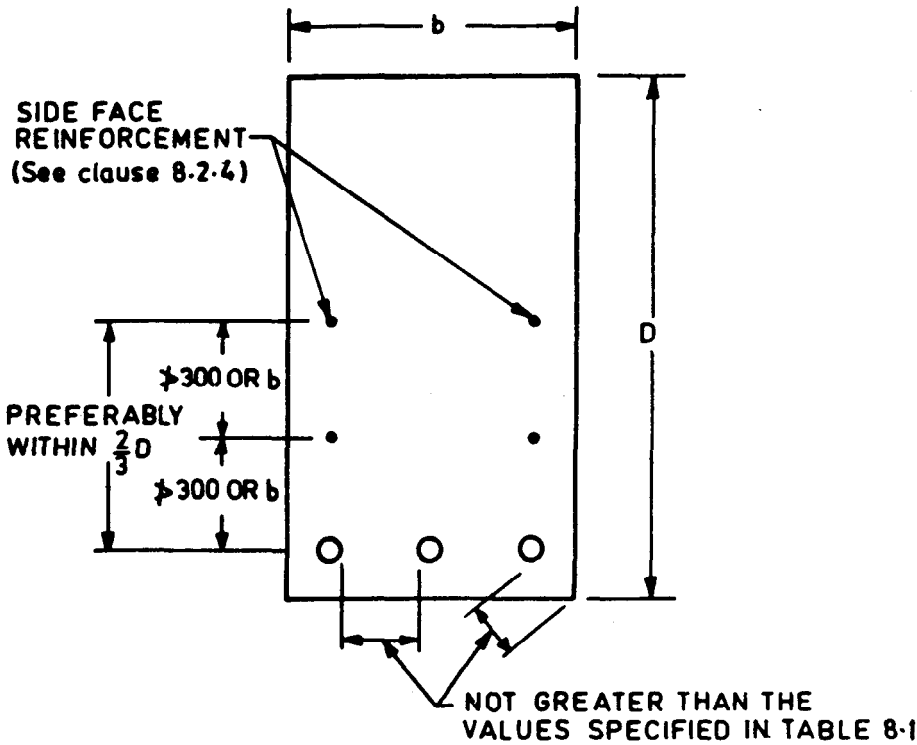

FIG. 8.3 REINFORCEMENT SPACING RULES FOR CRACK CONTROL

TABLE 8.1 MAXIMUM CLEAR DISTANCE BETWEEN TENSION BARS

| f_s | PERCENTAGE REDISTRIBUTION TO OR FROM SECTION CONSIDERED | | | | |
|-------------------|---|-----|-----|-----|-----|
| | -30 | -15 | 0 | +15 | +30 |
| | Clear Distance Between Bars | | | | |
| N/mm ² | mm | mm | mm | mm | mm |
| 250 | 215 | 260 | 300 | 300 | 300 |
| 415 | 125 | 155 | 180 | 210 | 235 |
| 500 | 105 | 130 | 150 | 175 | 195 |

NOTE — The spacings given in the table are not applicable to members subjected to particularly aggressive environments unless in the calculation of the moment of resistance, f_s has been limited to 300 N/mm² in limit state design.

8.2.3 Compression Reinforcement — The maximum area of compression reinforcement shall not exceed $0.04 bD$. Compression reinforcement shall be enclosed by stirrups for effective restraint. The anchorage length of straight bars in compression shall be equal to the development length of bars in compression.

8.2.4 Side Face Reinforcement — Where the depth of the web in a beam exceeds 750 mm side face reinforcement shall be provided along the two faces. The total area of such reinforcement shall be not less than 0.1 percent of the web area and shall be distributed equally on two faces at a

spacing not exceeding 300 mm or web thickness whichever is less (see Fig. 8.4).

8.3 Detailing of Shear Reinforcement

- a) A stirrup in the reinforced concrete beam shall pass around or be otherwise adequately secured to the outer most tension and compression reinforcement, and such stirrups should have both its ends anchored properly in any one of the fashion detailed in Fig. 8.5. In T-beams and I-beams, such reinforcement shall pass around longitudinal bars located close to the outer face of the flange.

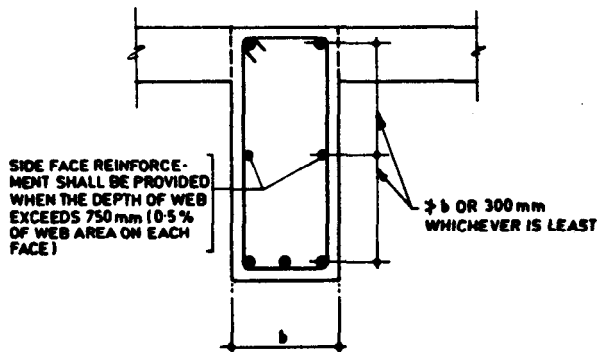
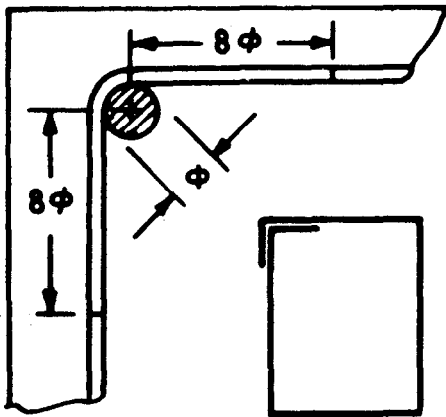
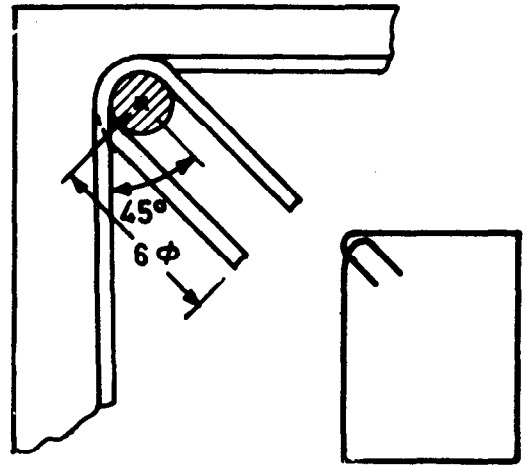

FIG. 8.4 SIDE FACE REINFORCEMENT IN BEAMS



8.5A



8.5B

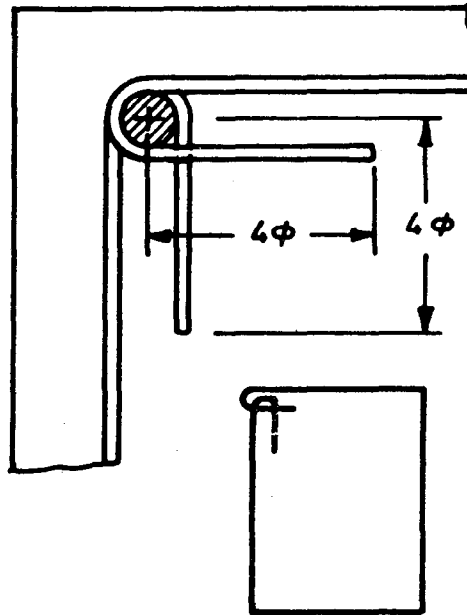

8.5C

FIG. 8.5 DIFFERENT WAYS OF ANCHORING ENDS OF STIRRUPS

While adopting stirrups, different shapes (see Fig. 8.6) may be considered depending on constructional requirements keeping in view the end anchorage requirements. However, while choosing a particular shape for a particular situation, its validity should be considered from structural point of view.

- b) *Bent-up Bars* — Tensile reinforcement which is inclined and carried through the depth of beam can also be considered to act as shear reinforcement provided it is anchored in accordance with 4.3.5 (see Fig. 8.7).

Usually two bars are bent up at a time at an angle 45° to 60° to the longitudinal axis of

the beam but other angles can also be adopted.

It is usual practice to combine bent up bars and vertical stirrups to resist the shear since some of the longitudinal bars are bent up when they are no longer required at the bottom (see Fig. 8.7).

- c) *Maximum Spacing* — The maximum spacing of shear reinforcement measured along the axis of the member shall not exceed $0.75 d$ for vertical stirrups and d for inclined stirrups at 45° , where d is the effective depth of the section under consideration. In no case shall it exceed 450 mm.

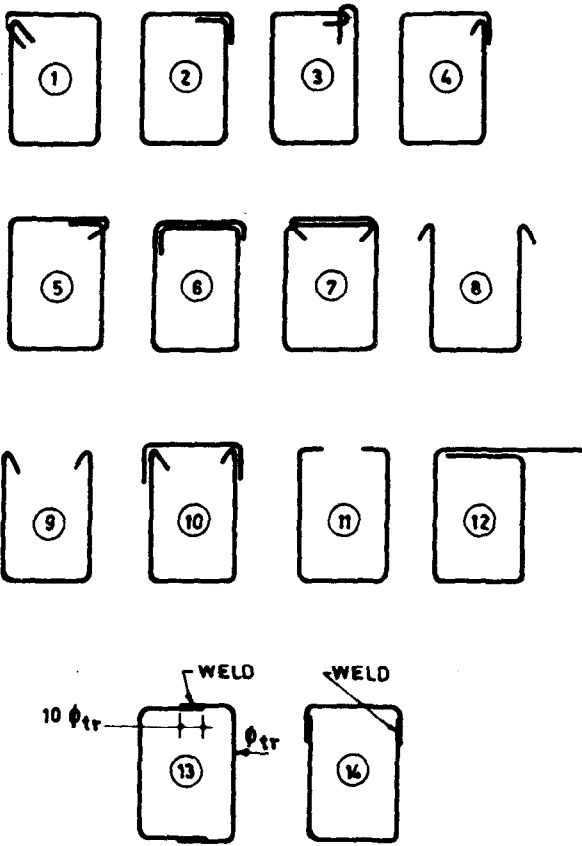

NOTE - Preferred shapes for torsion--1,2,3,4,6,7,13 and 14

FIG. 8.6 DIFFERENT SHAPES OF STIRRUPS

d) *Use of Multi-Legged Stirrups* — Multi-legged stirrups are required from the consideration of shear stresses in the beam, or where restraint against the buckling of bars in compression is needed. The rules for stirrups reinforcing steel in compression are the same as those for columns. The vertical stirrups may be provided as two-legged stirrups, four-legged stirrups or six-legged stirrups at the same section according to actual requirements (see Fig. 8.8). Open type stirrups as shown in Fig. 8.9 may be used for beam-slab construction where the width of rib is more than 450 mm.

e) *Stirrups in Edge Beams* — Where designer shows stirrups in any edge or spandrel beam, these stirrups shall be closed and at least one longitudinal bar shall be located in each corner of the beam section, the size of this bar is to be at least equal to the diameter of the stirrup but not less than 12 mm. These details shall be clearly indicated by the designer. Typical cross-sectional details are shown in Fig. 8.10 for normal and up-turned edge or spandrel beams. For easier placing of the longitudinal bars in the beam, details for two-piece closed stirrups are also shown. For the same reason, 90° stirrup hook is preferred.

f) *Minimum Reinforcement* — The minimum shear reinforcement in the form of stirrups shall not be less than the following (see Fig. 8.11).

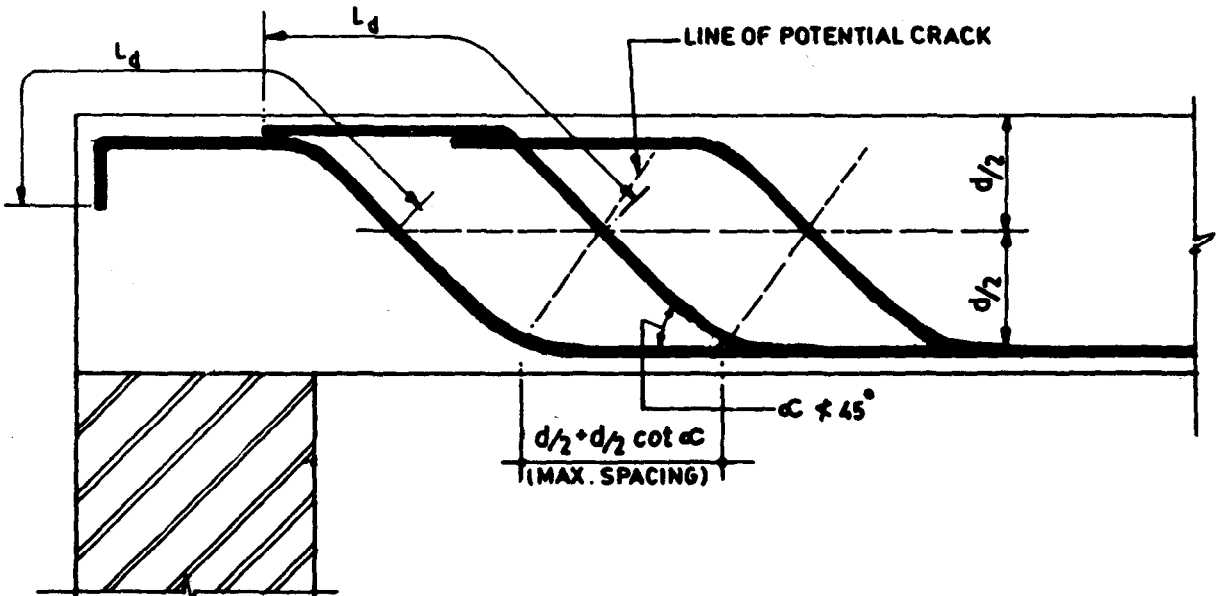

8.7A REQUIREMENTS FOR BENT-UP BARS

FIG. 8.7 BENT-UP BARS (Continued)

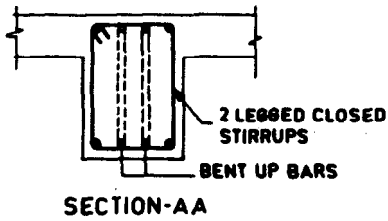
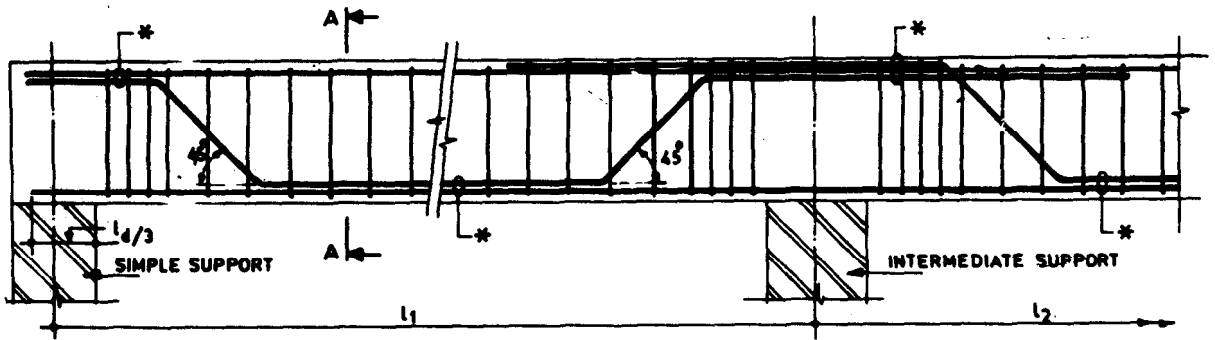

* BARS AT SAME LEVEL

8.7B TYPICAL ARRANGEMENT OF BENT-UP BARS AND VERTICAL STIRRUPS IN A CONTINUOUS BEAM

FIG. 8.7 BENT-UP BARS

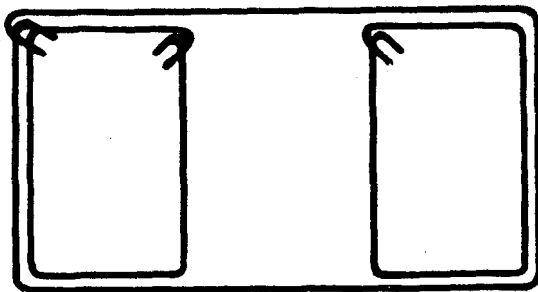

8.8A

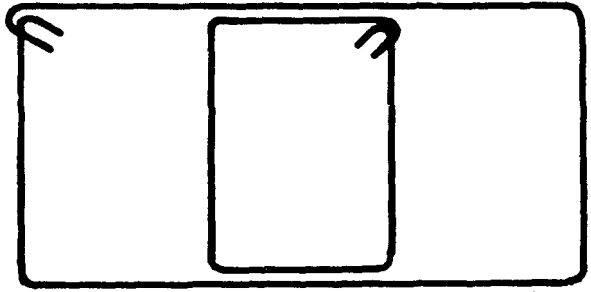

8.8B

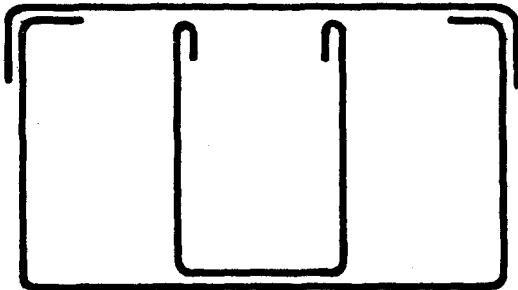

8.8C

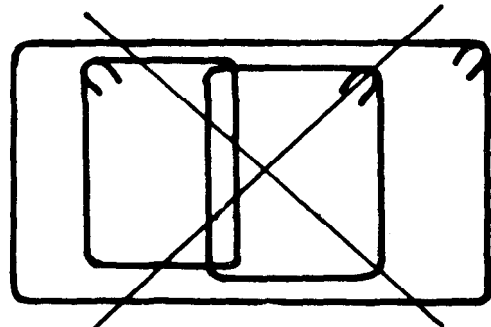

8.8D

THIS ARRANGEMENT IN WHICH LINKS OVERLAPS SHOULD BE AVOIDED

FIG. 8.8 EXAMPLES OF MULTI-LEGGED STIRRUPS

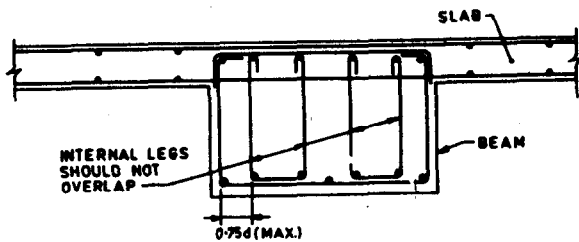

FIG. 8.9 MULTI-LEGGED OPEN TYPE STIRRUPS CROSS-SECTION OF A BROAD SHALLOW BEAM WITH 6-LEGGED STIRRUPS

$$A_{sv}, \text{ Min} = \frac{0.4 b S_v}{f_y}$$

where

A_{sv} = total cross-sectional area of stirrup legs effective in shear;

b = breadth of the beam or breadth of the web of flanged beam; and
 S_v = stirrup spacing along the length of the member;
 f_y = characteristic strength of the stirrup reinforcement in N/mm^2 which shall not be taken greater than $415 N/mm^2$.

However, in members of minor structural importance such as lintels, or where the maximum shear stress calculated is less than the permissible value, this provision need not be complied with.

g) *Beam of Varying Depth* — Detail stirrup sizes individually where beams have varying depth. A range of stirrup sizes has to be detailed (see Fig. 8.12 and also 8.10).

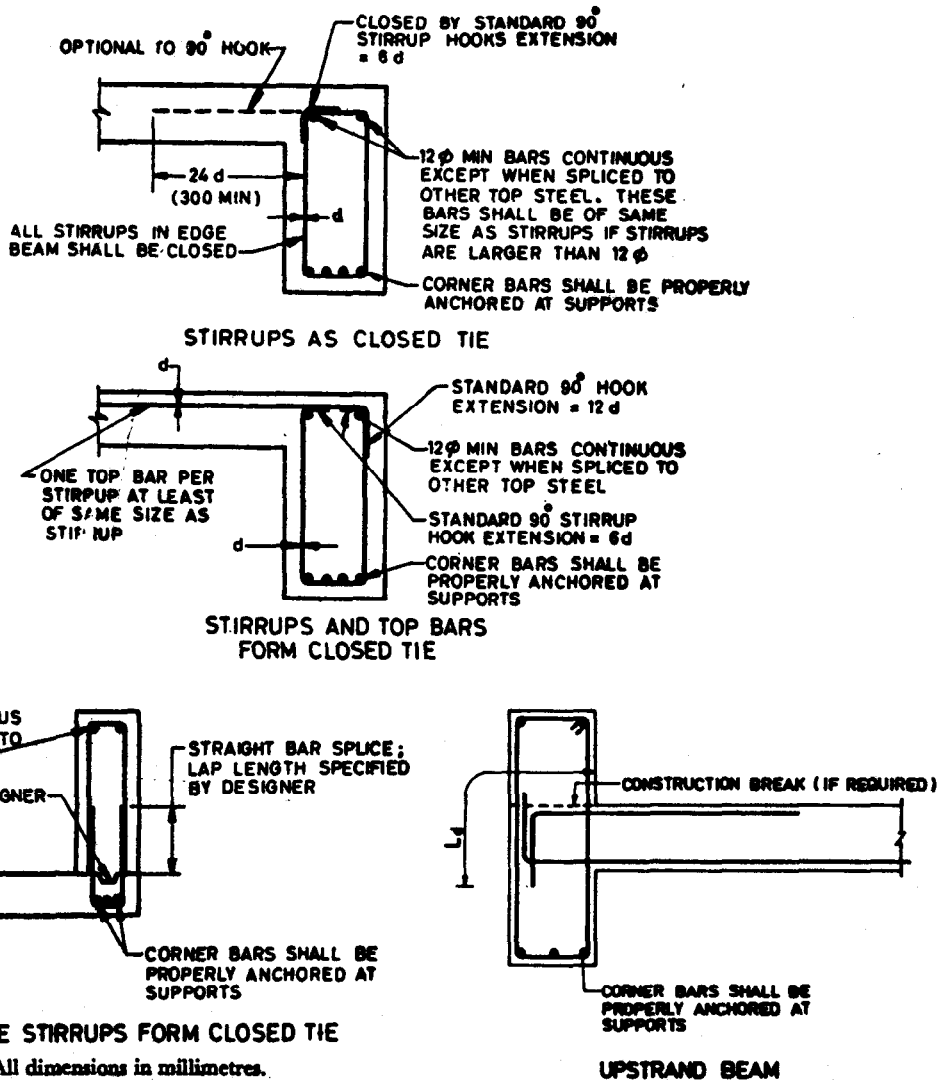

FIG. 8.10 TYPICAL DETAILS OF REINFORCEMENT IN EDGE AND SPANDREL BEAM

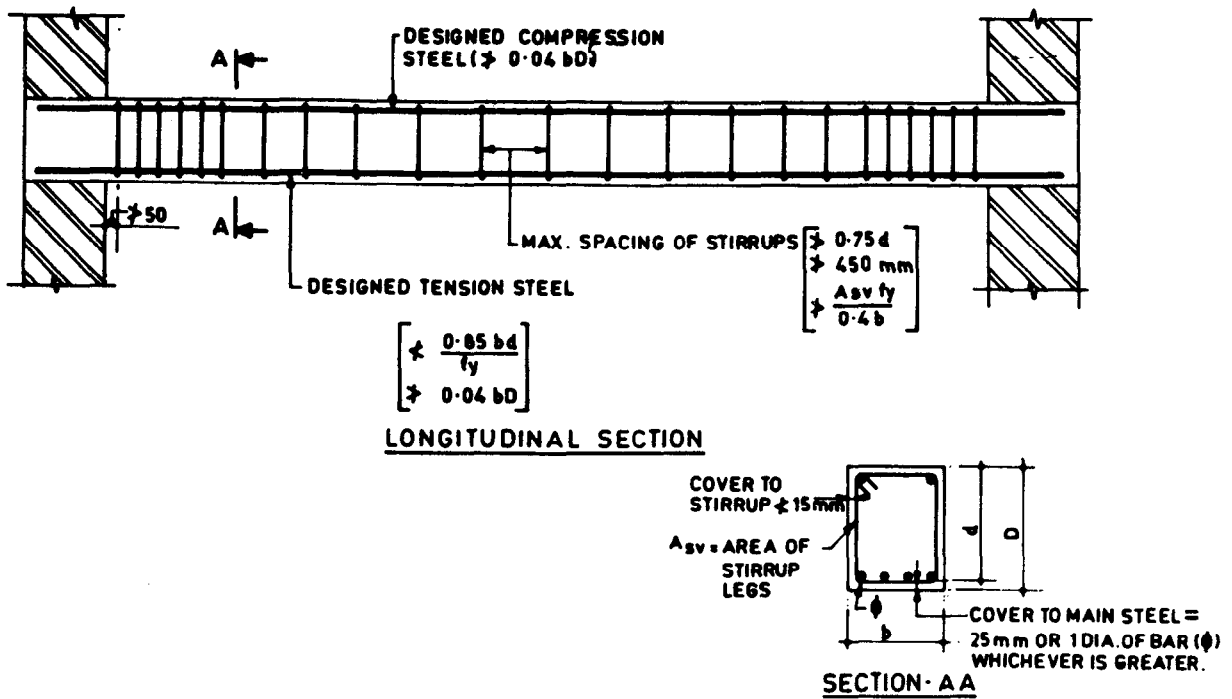

FIG. 8.11 REINFORCEMENT REQUIREMENTS FOR BEAMS

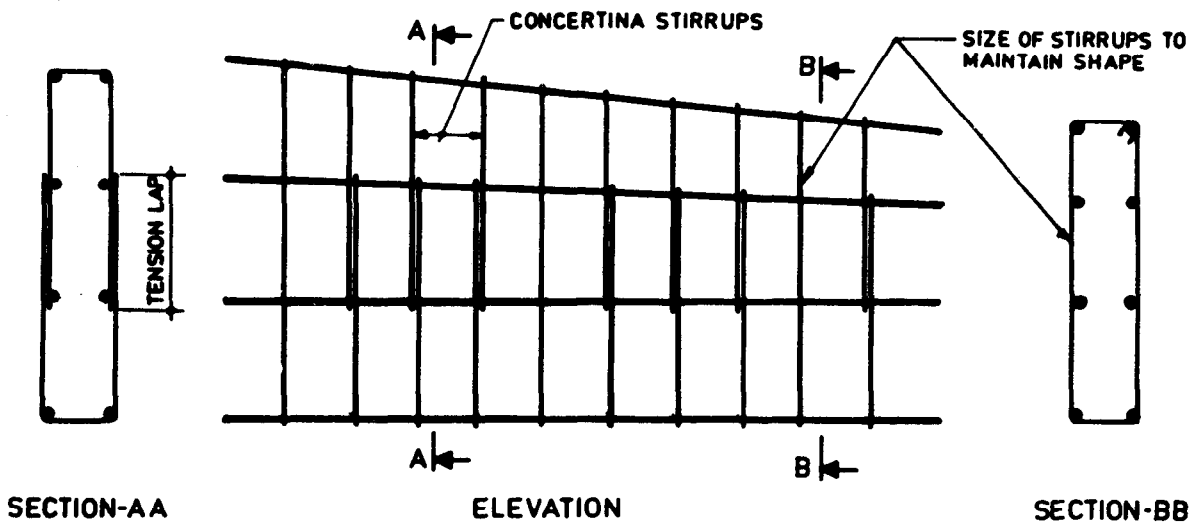

FIG. 8.12 USE OF CONCERTINA STIRRUPS IN BEAMS OF VARYING DEPTH

h) *Force not Applied to Top of Beam* — Where a load transfer is through the bottom or side of a beam (for example, where one beam frames into another), ensure that there is sufficient suspension or hang-up reinforce-

men. at the junction in the main beam in the form of stirrups to transfer the force to the top of the beam. If the load is large, bent-up bars may also be used in addition to stirrups (see Fig. 8.13).

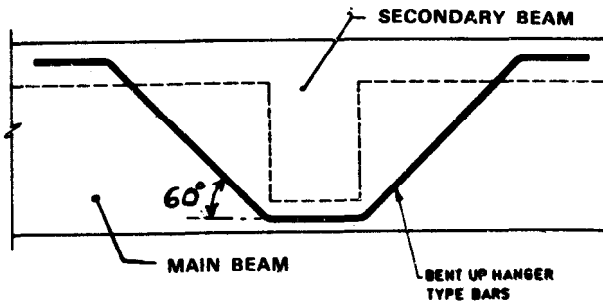
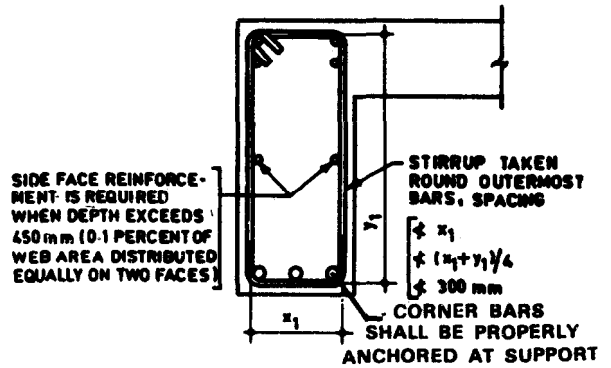

FIG. 8.13



8.14A SHEAR AND TORSION REINFORCEMENT IN BEAMS

8.4 Torsion Reinforcement — When a member is designed for torsion, reinforcement for the same shall be provided as follows (see Fig. 8.14A):

- The transverse reinforcement for torsion shall be rectangular closed stirrups placed perpendicular to the axis of the member. The spacing of the stirrups shall not exceed the least of x_1 , $(x_1 + y_1)/4$ and 300 mm, where x_1 and y_1 are respectively the short and long dimensions of the stirrup. In a beam with multi-legged stirrup, only the stirrup going around the outer face shall be considered to resist torsional force. In members having a complex cross-section (such as I and T-sections), each part (flanges, ribs, webs, etc.) should contain closed stirrups of its own (see Fig. 8.14B and C).
- Longitudinal reinforcement shall be placed as close as is practicable to the corners of the cross-section and in all cases there shall be at least one longitudinal bar in each corner of the ties.
- When the cross-sectional dimensions of the members exceeds 450 mm, additional longitudinal reinforcements shall be provided at the side faces and the total area of such reinforcement shall be not less than 0.1 percent of the web area and shall be distributed equally on two faces at a spacing not exceeding 300 mm or web thickness whichever is lower.

8.5 Curtailment of Reinforcement — The extent of curtailment of main reinforcement in beams should be related to the bending moment diagram subject to the conditions specified in Section 4. However, simplified curtailment rules illustrated in Fig. 8.15, 8.16 and 8.17 may be used for continuous beams, simply supported beams and cantilever beams, respectively under the following circumstances:

- the beams are designed for predominantly uniformly distributed loads; and
- in the case of continuous beams, the spans are approximately equal (which do not differ by more than 15 percent of the longest).

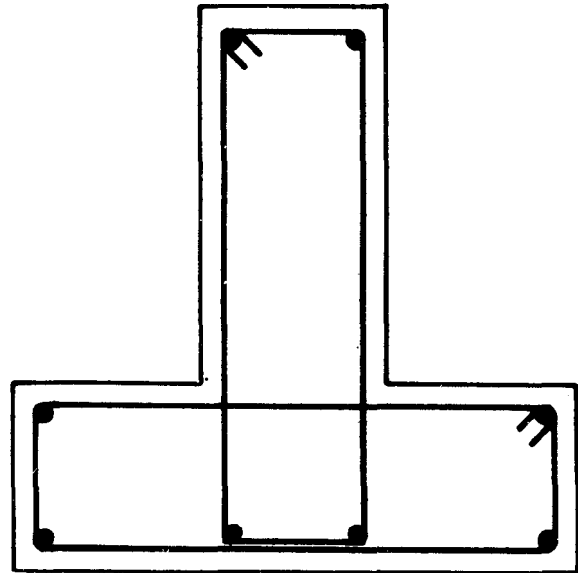

8.14B

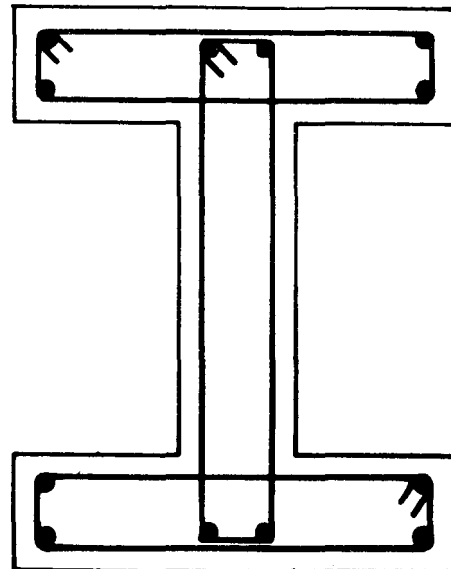

8.14C

FIG. 8.14 SHEAR AND TORSION REINFORCEMENT IN RECTANGULAR AND FLANGED BEAMS

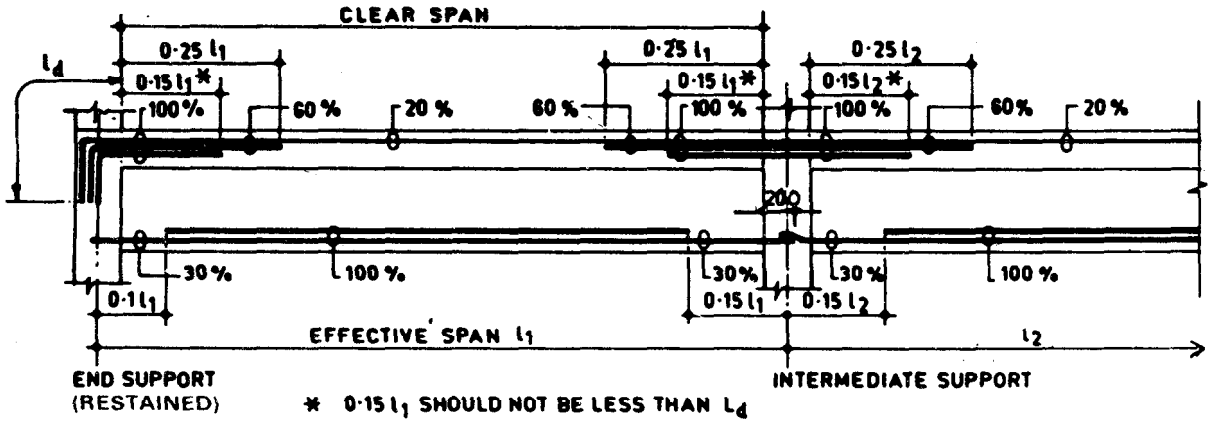

NOTE - Applicable to continuous beams with approximately equal spans (not differing more than 15 percent) and subjected to predominantly U.D.L., and designed without compression steel.

FIG. 8.15 SIMPLIFIED CURTAILMENT RULES FOR CONTINUOUS BEAMS

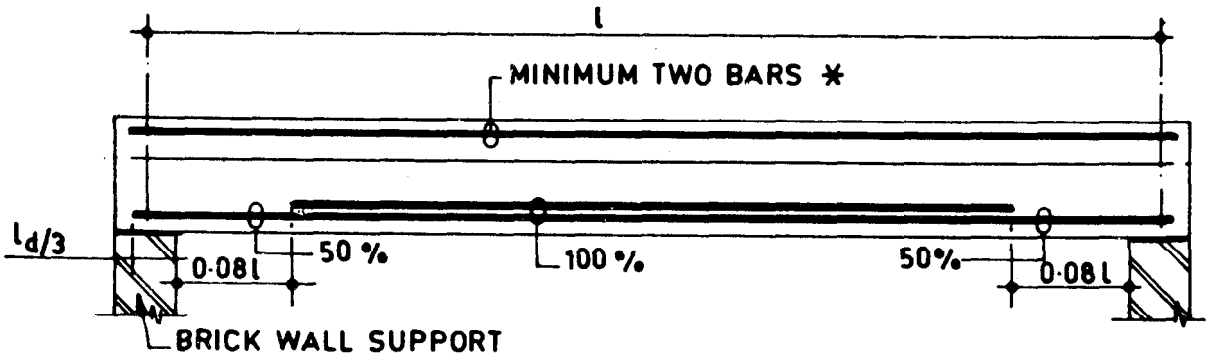

*In case partially restraint members, 35 percent of the reinforcement shall also be provided for negative moment at the support and fully anchored.

FIG. 8.16 SIMPLIFIED CURTAILMENT RULES FOR SIMPLY SUPPORTED BEAM

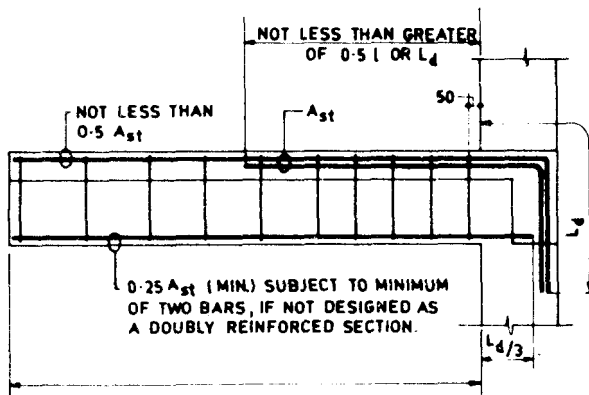

8.17A CANTILEVER BEAM PROJECTING FROM A COLUMN

FIG. 8.17 SIMPLIFIED CURTAILMENT RULES FOR A CANTILEVER BEAM (Continued)

8.6 Edge and Spandrel Beam — T-beams or L-beams are usually designed as internal and external beams supporting a floor slab; where part of the slab form the horizontal portions of the T- or L-beam.

Where the reinforcement of a slab which is considered as the flange of T- or L-beam, is parallel to the beam, transverse reinforcement extending to the lengths indicated in Fig. 8.18 shall be provided. If the quantity of such transverse reinforcement is not specially determined by calculations it shall not be less than 60 percent of main reinforcement in the centre of the span of slab constituting the flange.

8.7 Corners and Cranked Beams — Recommendations for various methods of reinforcing corners are giving herein based on reference 6. It is to be noted that closing corners present no major

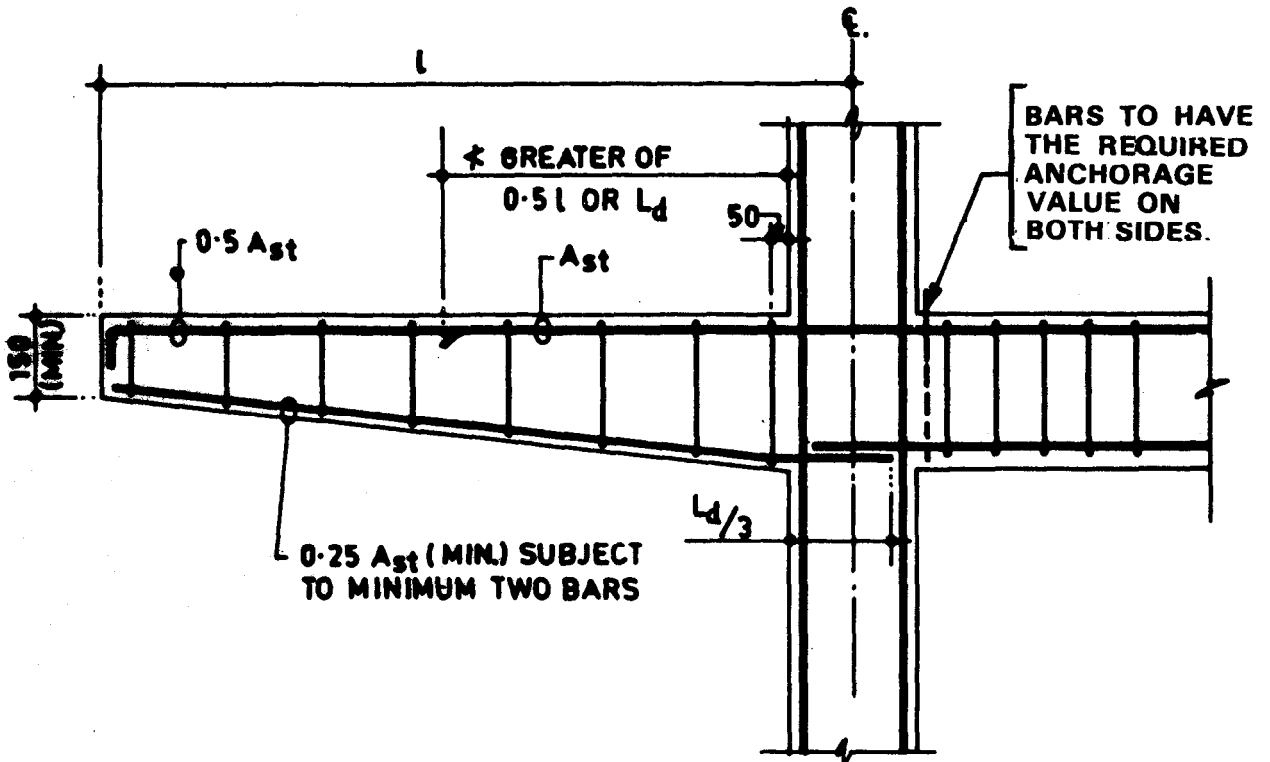

8 17B CANTILEVER BEAM PROJECTING FROM A BEAM OVER A COLUMN

FIG. 8.17 SIMPLIFIED CURTAILMENT RULES FOR A CANTILEVER BEAM

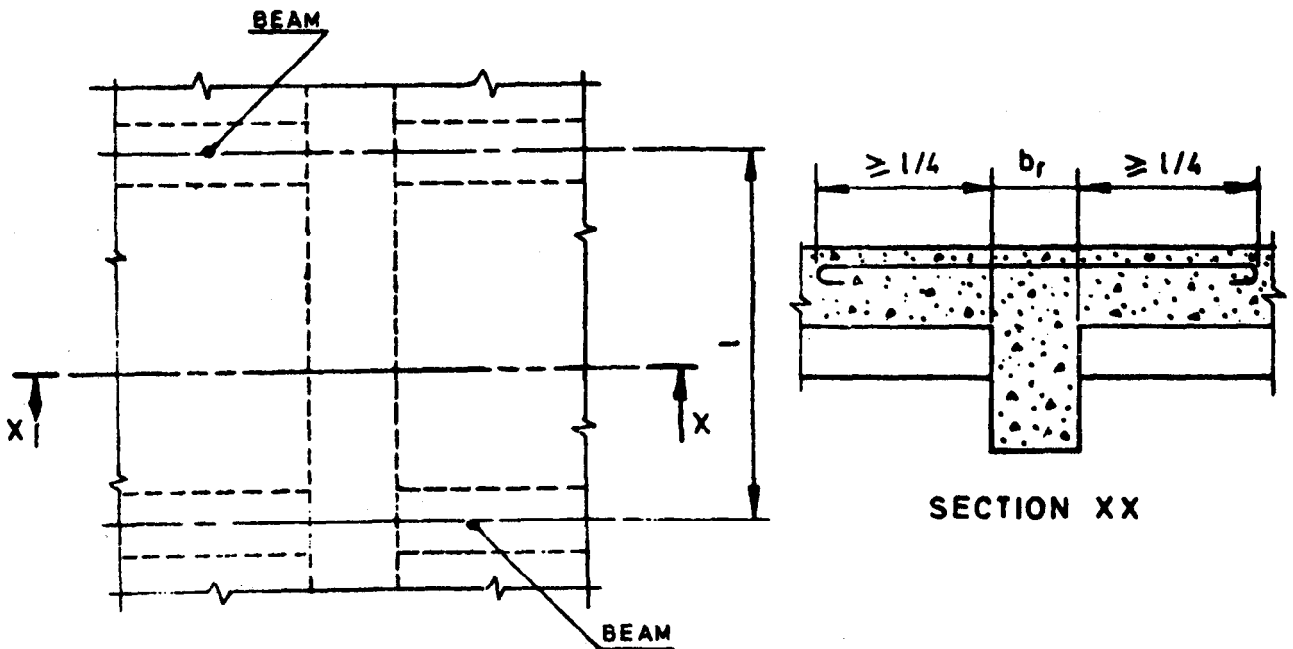

FIG. 8.18 TRANSVERSE REINFORCEMENT IN FLANGE OF T-BEAM WHEN MAIN REINFORCEMENT OF SLAB IS PARALLEL TO BEAM

problem, but opening corners require careful detailing (see Fig. 8.19 and Fig. 8.20).

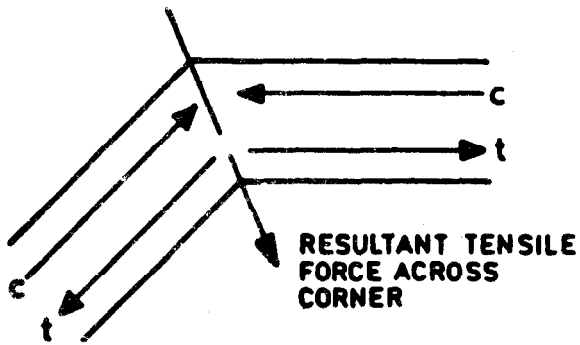

FIG. 8.19 OPENING CORNER

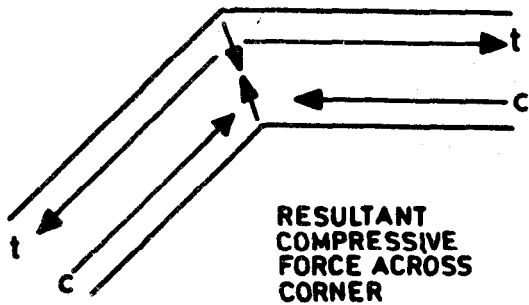

FIG. 8.20 CLOSING CORNER

8.7.1 90°-Opening Corners With 1 Percent Reinforcement or Less — Where the amount of reinforcement in the beam is equal to or less than 1 percent, detail the reinforcement as shown in Fig. 8.21 or Fig. 8.22, the splay steel being equal to 50 percent of the main steel.

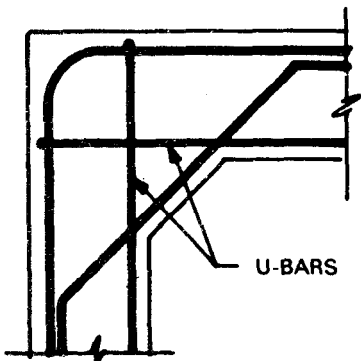

FIG. 8.21

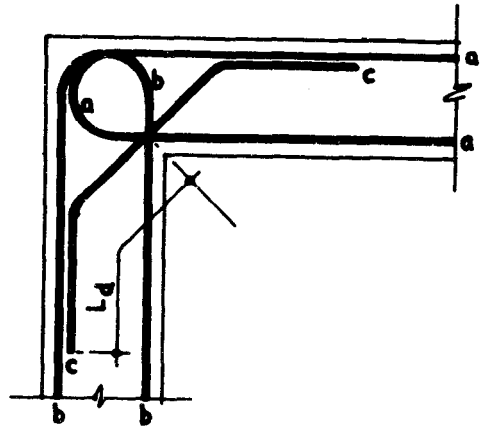

FIG. 8.22 HAIRPIN WITH SPLAY REINFORCEMENT

8.7.2 90°-Opening Corners With More Than 1 Percent Reinforcement — If the area of reinforcement exceeds one percent, provide transverse steel as well as splay steel as in Fig. 8.23. (The use of a splay is also strongly recommended.)

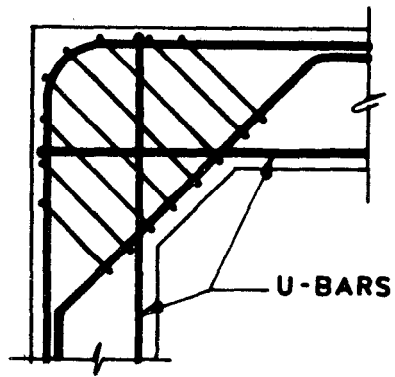

FIG. 8.23

8.7.3 Cranked Beams — The recommended methods of detailing are shown in Fig. 8.24, 8.25 and 8.26.

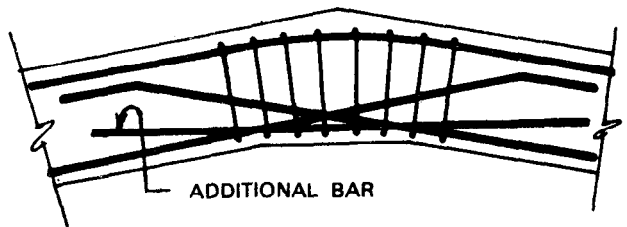

FIG. 8.24

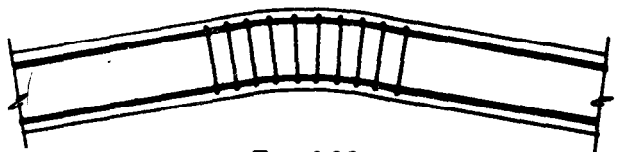

FIG. 8.25

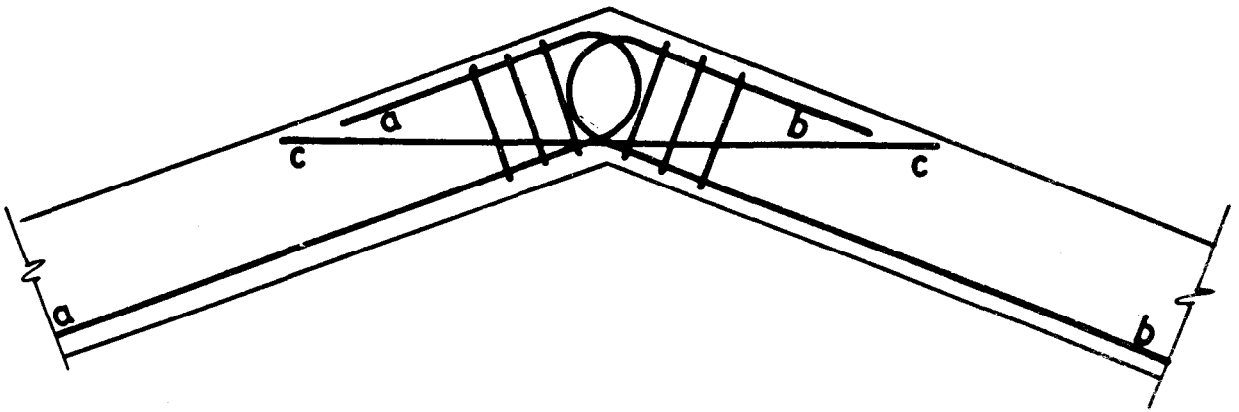

FIG. 8.26

8.7.4 Beam and Column Junction — Where a column extends above a beam, bend the beam top reinforcement down into the column but if it is necessary to bend the bars up, detail additional steel as in Fig. 8.27.

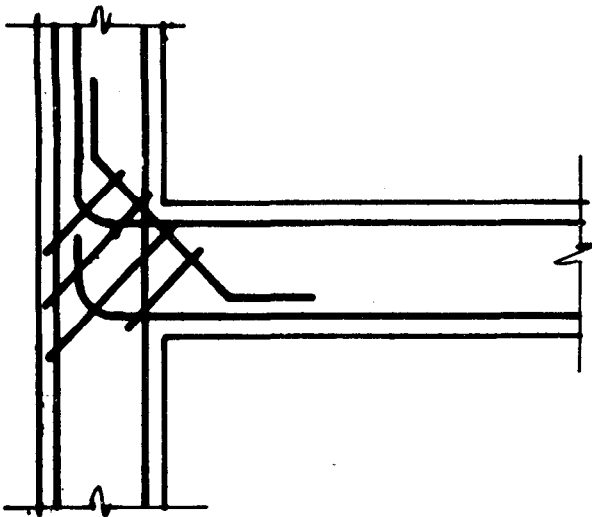

FIG. 8.27

8.7.5 Closing Corners — At closing corners provide adequate radii (equal to at least 7.5 bar diameters) and some additional reinforcement as in Fig. 8.28.

8.8 Beam of Different Depths — Typical arrangements of reinforcement over the support when the beam on either side of the support are of different depths is shown in Fig. 8.29.

8.9 Tie Members — As a tie is under pure tension there is no tendency to burst like an axially loaded column and therefore binders are not required. But, in order to form the longitudinal bars into a cage, a minimum number of links is used. As there is theoretically no shear or bending moment acting on a tie, only main longitudinal reinforcement is required. The main

8.9.1 End Details — These shall provide adequate anchors and correct bond lengths. In

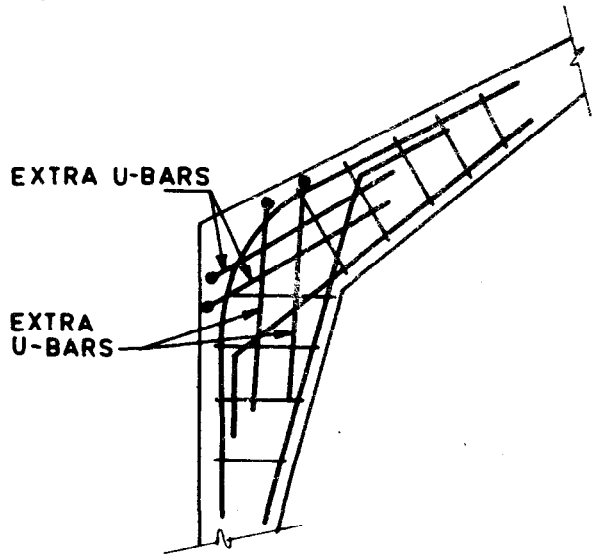

FIG. 8.28

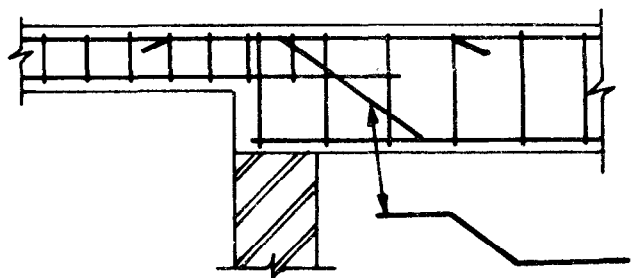

FIG. 8.29 BEAMS AT DIFFERENT DEPTHS

consideration is the end conditions where a method should be devised to anchor the tie and/or spread its axial load into the connecting members.

practice a small splay at the ends of the tie is made to allow for any slight moment that may be induced at the ends. Simple end details for light loading are shown in Fig. 8.30. The ties are shown by the arrows.

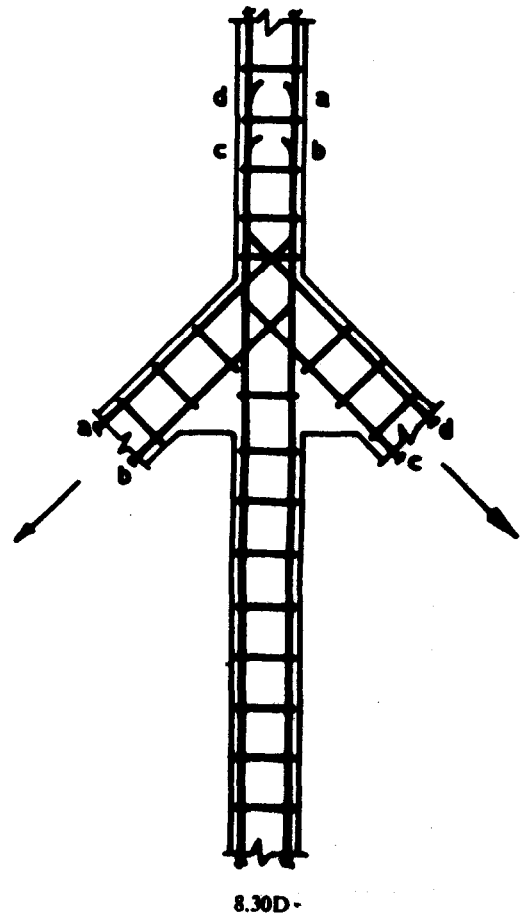
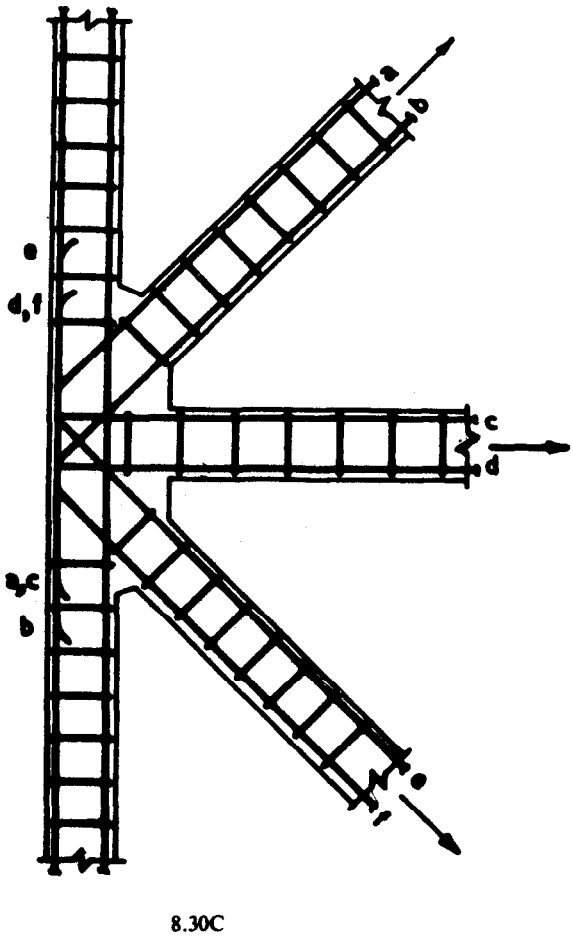
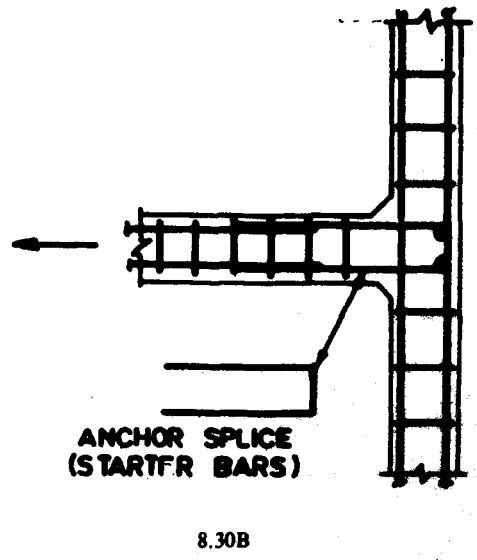
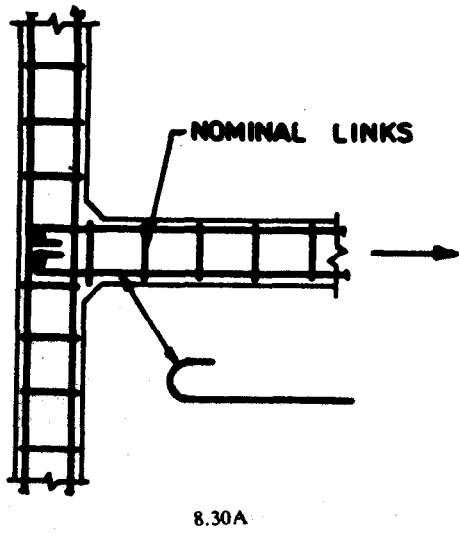

FIG. 8.30 TIE END CONNECTIONS FOR LIGHT LOADING

For heavier axial loading, the ends shall be more splayed out to distribute the load adequately. Typical details are shown in Fig. 8.31.

In Fig. 8.31 (A and B) it will be seen that as the splay is increased in size, the embedded and hence bond length of the main tie bars is also increased.

In Fig. 8.31C extra links or hoops shall be provided as shown to resist the tendency of the large loop to burst under axial load. In Fig. 8.31 the main bars have been shown with double lines for clarity. When detailing they would be shown thick lines in the normal way.

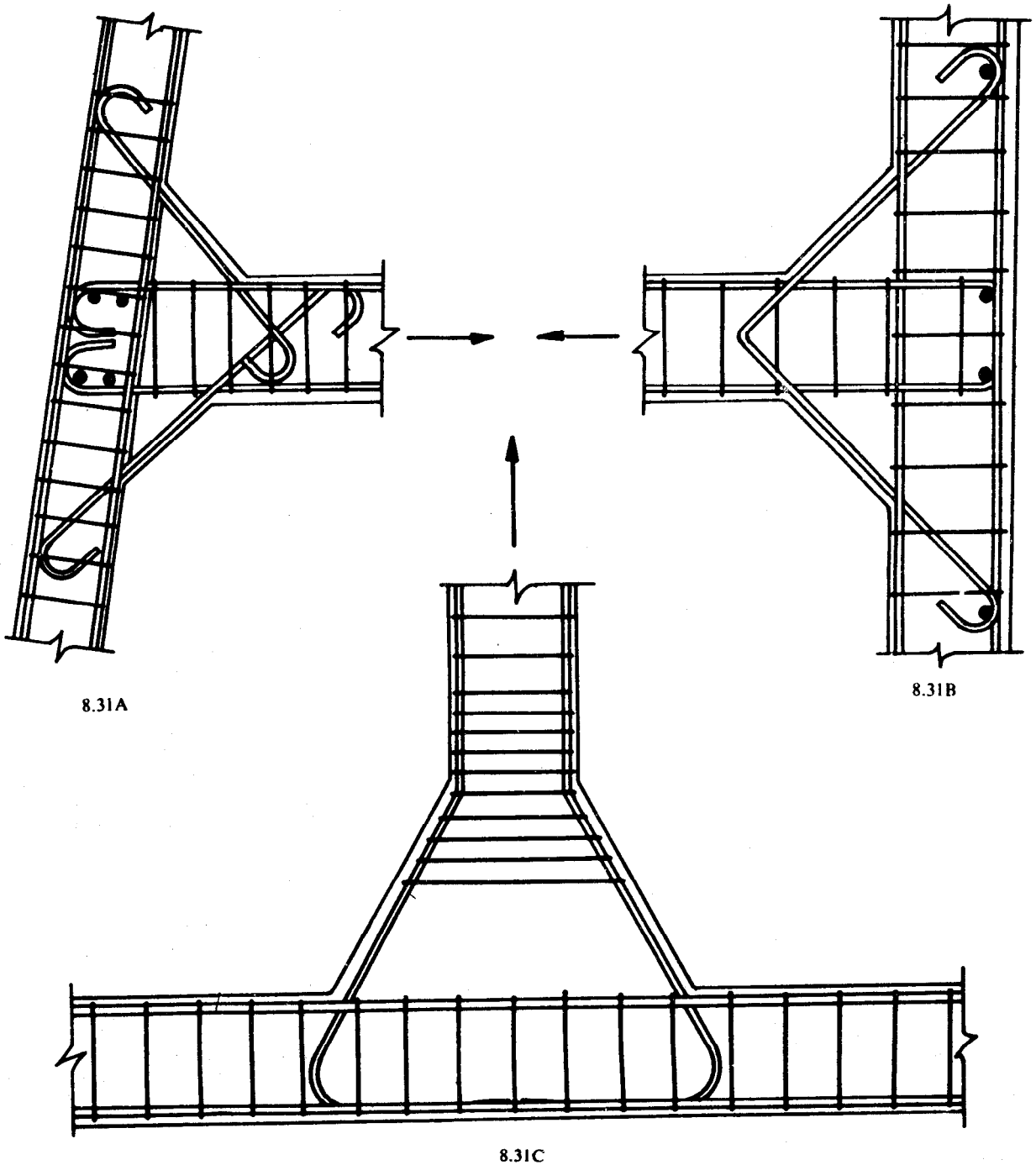

FIG. 8.31 TIE END CONNECTIONS FOR HIGH LOADING

8.10 Haunched Beams — In very heavily loaded beams, for example a warehouse structure, the shear stress and negative bending moment at the supports will be high. An economical method of overcoming this problems is to provide the beams with haunches as shown in Fig. 8.32. There are no rules governing the size of haunches, but those shown in Fig. 8.32 are considered ideal.

reinforcement in an end external haunch. The main bars are carried through the haunch as if it did not exist, with pairs of bars *a*, *b*, *c*, etc, stopped off in accordance with a cut-off bending moment diagram. Bars *h* are placed parallel to the haunch to carry vertical links (omitted in the figure for clarity).

8.10.1 Main Reinforcement in haunches — Figure 8.33 shows the typical main tensile

A similar method of reinforcing to that shown in Fig. 8.33 can also be used for internal haunches. This is shown in Fig. 8.34.

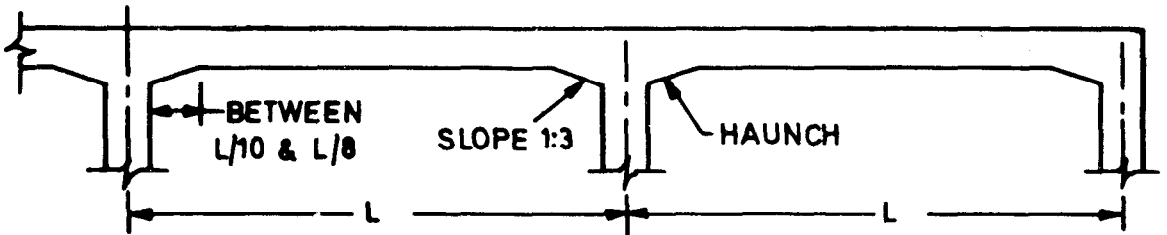

FIG. 8.32 BEAM HAUNCHES

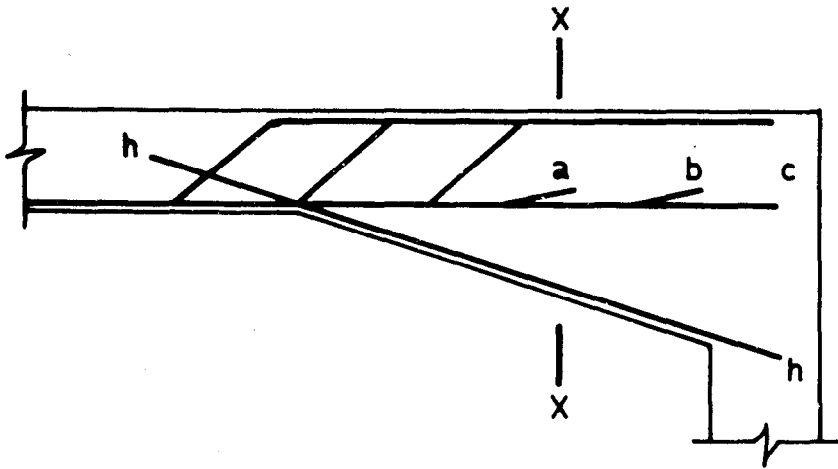

FIG. 8.33 MAIN REINFORCEMENT IN END HAUNCHES (See FIG. 8.33 FOR SECTION XX)

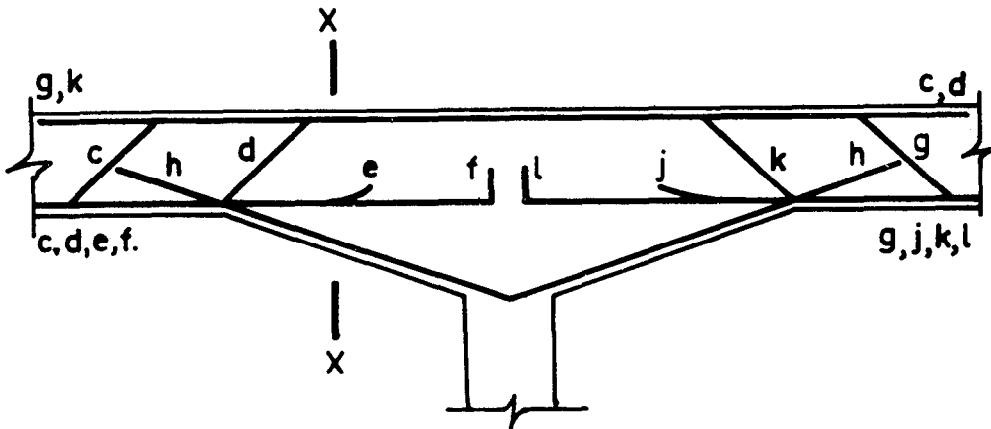

FIG. 8.34 MAIN REINFORCEMENT IN HAUNCHES (See FIG. 8.37 FOR SECTION XX)

8.10.2 Stirrups in Haunches — The stirrups in haunches can either be positioned normally to the haunch as shown in Fig. 8.35A, or placed vertically as in Fig. 8.35B. Most designers prefer method shown in Fig. 8.35B.

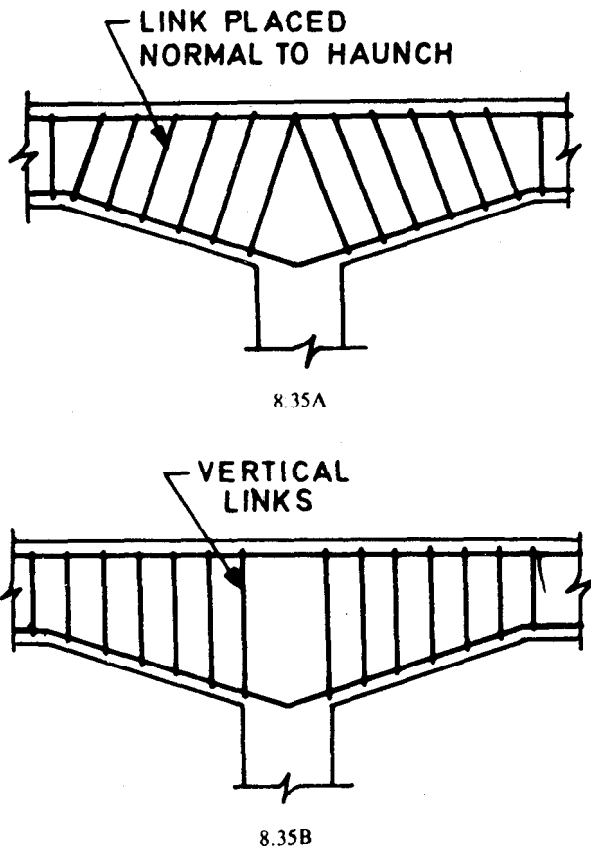

FIG. 8.35 LINKS OR TIES IN HAUNCHS

If in Fig. 8.33 and 8.34, the h bars were placed near the outside edge of the beam they would foul the outside main horizontal bars. They should, therefore, be placed on the inside as shown in Fig. 8.36 so that two different sets of stirrups are required throughout the whole length of the haunch (see 8.10).

8.11 Beam of Varying Depth — Stirrups need to be detailed individually wherever beams have varying depths and a range of stirrup sizes have to be adopted.

8.11.1 The different stirrup sizes may be reduced in number by using concertina stirrups (see Fig. 8.12) with the legs lapped with tension lap length. The difference between the lengths of successive groups should be at least 50 mm. In order to maintain the correct size of the member, use closed stirrups at centre-to-centre distances of at least 1000 mm. Ensure that concertina stirrups are properly tied and maintained in position during concreting.

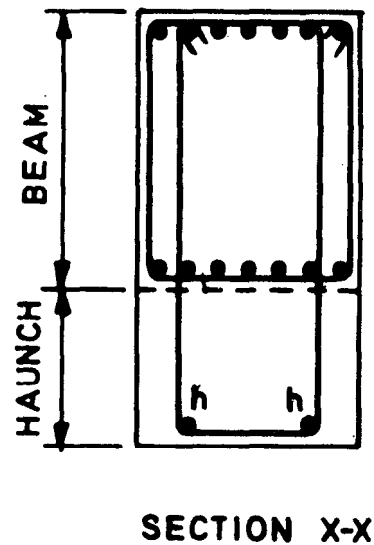

FIG. 8.36 HAUNCH LINKS

8.12 Intersection of Beams

8.12.1 General — Ensure that, at beam-beam intersections, reinforcement is so arranged that layers in mutually perpendicular beams are at different levels.

8.12.2 Top Steel — It is good practice, for the following reasons, to pass the secondary beam steel over the main beam steel:

- secondary beam steel is usually of smaller diameter and requires less cover, and
- secondary beam top reinforcement is available to act as a support for the slab top reinforcement.

Where the main beam is very heavily stressed, however, it may be more economical to pass the main beam steel over the secondary reinforcement.

8.12.3 Bottom Steel — To accommodate bottom bars, it is good practice to make secondary beams shallower than main beams, even if by only 50 mm (see Fig. 8.37). Where beam soffits are at the same level, the secondary beam steel should pass over the main beam steel. Unless the secondary beam span is short, bars of diameter less than 25 mm be draped (see Fig. 8.38). Cranking of bottom bars is usually not necessary.

If it is required that the beam cages be pre-assembled, provide splice bars 7.6).

8.13 Openings in the Web — Adjacent openings for services in the web of flexural members shall be arranged so that no potential failure planes, passing through several openings, can develop. In considering this, the possible reversal of shear

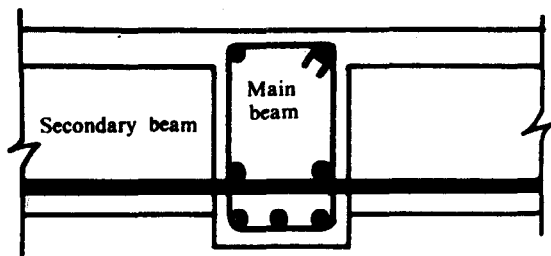

FIG. 8.37

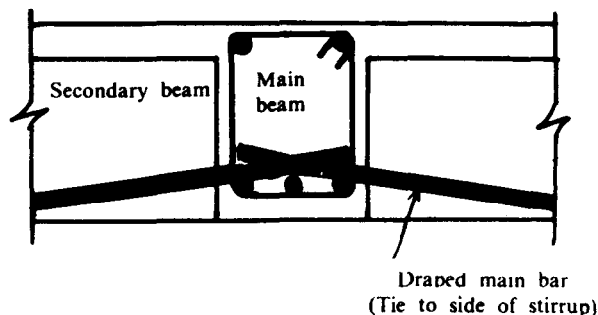

FIG. 8.38

Draped main bar
(Tie to side of stirrup)

force, associated with the development of the flexural overstrength of the members, should be taken into account.

8.13.1 Small square or circular openings may be placed in the mid-depth of the web provided that cover requirements to longitudinal and transverse reinforcement are satisfied, and the clear distance between such openings, measured along the member, is not less than 150 mm. The area of small openings shall not exceed 1 000 mm² for members with an effective depth, d , less than or equal to 500 mm, or $0.004 d^2$ when the effective depth is more than 500 mm.

NOTE— Small openings with areas not exceeding those specified in 8.13.1 are considered not to interfere with the development of the strength of the member. However, such openings must not encroach into the flexural compression zone of the member. Therefore, the edge of a small opening should be no closer than $0.33 d$ to the compression face of the member, as required by 8.12.3. When two or more small openings are placed transversely in the web, the distance between the outermost edges of the small openings should be considered as being equivalent to the height of one large opening and the member should be designed accordingly.

8.13.2 Webs with openings larger than that permitted by 8.12.1 shall be subject to rational design to ensure that the forces and moments are adequately transferred in the vicinity of the openings. This will require the design of orthogonal or diagonal reinforcement around such openings.

8.13.3 Whenever the largest dimension of an opening exceed one-quarter of the effective depth of the member, it is to be considered large. Such openings shall not be placed in the web where they could affect the flexural or shear capacity of the member, nor where the total shear stress exceed $0.36 \sqrt{f_{ck}}$, or in potential plastic hinge zones. In no case shall the height of the opening exceed $0.4 d$ nor shall its edge be closer than $0.33 d$ to the compression face of the member to

ensure that the moments and shear forces can be effectively transmitted by the compression zone of the member.

8.13.4 For openings defined by 8.13.3, longitudinal and transverse reinforcement shall be placed in the compression side of the web to resist one and one-half times the shear across the opening. Shear transfer in the tension side of the web shall be neglected.

NOTE— Only the part of the web above or below an opening which is in compression should be considered to transmit shear. The stiffness of the tension part is considered to be negligible because of extensive cracking. The amount, location and anchorage of the longitudinal reinforcement in the compression part of the web above the opening must be determined from first principles so as to resist one and one-half times the moment induced by the shear force across the opening. Similarly shear reinforcement in the compression chord adjacent to the opening must resist 150 percent of the design shear force. This is to ensure that no failure occurs as a result of the local weakening of the member due to the opening. Effective diagonal reinforcement above or below the opening, resisting one and one-half times the shear and moment, is also acceptable.

8.13.5 Transverse web reinforcement, extending over the full depth of the web, shall be placed adjacent to both sides of a large opening over a distance not exceeding one-half of the effective depth of the member to resist twice the entire design shear across the opening.

NOTE— At either side of an opening where the moments and shear forces are introduced to the full section of a beam, horizontal splitting or diagonal tension cracks are to be expected. To control these cracks, transverse reinforcement resisting at least twice the design shear force, must be provided on both sides of the opening. Such stirrups can be distributed over a length not exceeding $0.5 d$ at either side immediately adjacent to the opening.

8.13.6 A typical detail of reinforcement around a large opening in the web of a beam, complying with the above requirements, are shown in Fig. 8.39.

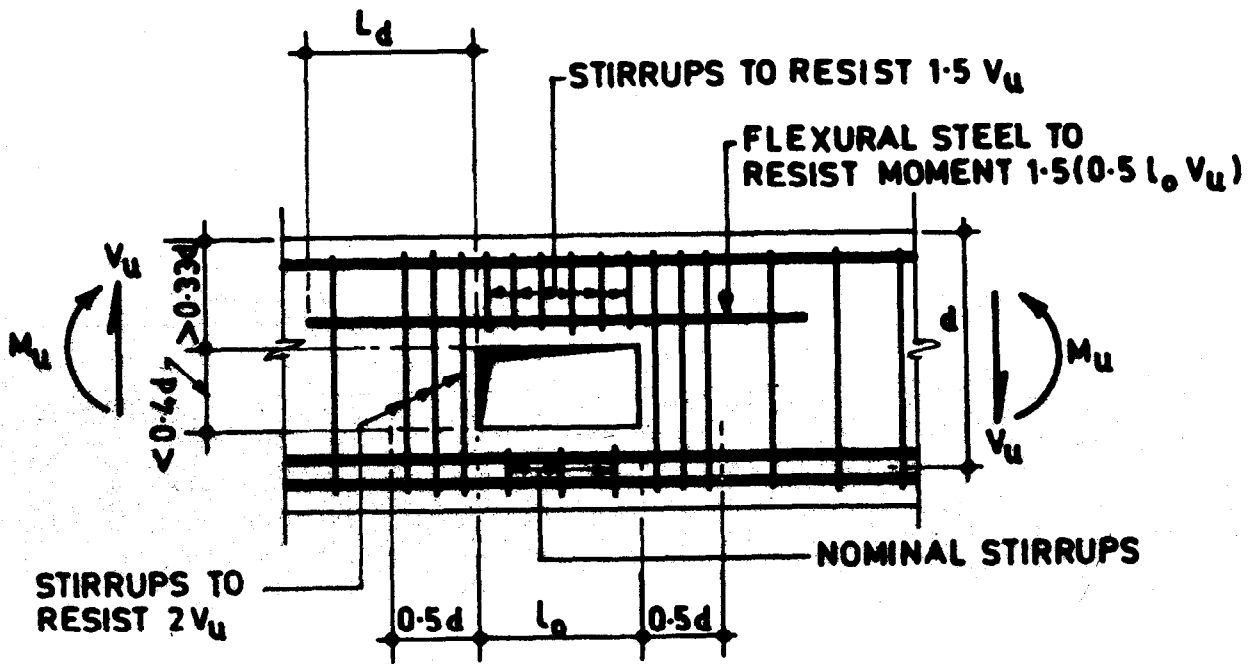

FIG. 8.39 DETAILS OF REQUIREMENTS AT A LARGE OPENING IN THE WEB OF A BEAM

SECTION 9
Floor Slabs

SECTION 9

FLOOR SLABS

9.0 Solid Slabs — The requirements specified in 9.1 to 9.7.2.2 apply to solid slabs other than flat slabs.

9.1 Minimum Reinforcement — In solid reinforced concrete slabs, the reinforcement in either direction expressed as a percentage of the gross-sectional area of the concrete shall not be less than:

- a) 0.15 percent where plain bars are used, and
- b) 0.12 percent where high yield strength (hot rolled and cold twisted) deformed bars or welded wire fabric are used.

9.2 Spacing, Cover and Diameter

9.2.1 Spacing

- a) The pitch of the bars for main tensile reinforcement in solid slab shall be not more than thrice the effective depth of such slab or 450 mm, whichever is smaller.
- b) The pitch of the distribution bars or the pitch of the bars provided against shrinkage and temperature shall not be more than 5 times the effective depth of such slab or 450 mm, whichever is smaller. Table C-6 (see Appendix C) give area of bars for different spacing and diameter of bars.

9.2.2 Cover

- a) The cover at each end of reinforcing bar shall be neither less than 25 mm nor less than twice the diameter of such bar.
- b) The minimum cover to reinforcement (tension, compression, shear) shall be not less than 15 mm, nor less than the diameter of bar.

9.2.3 Bar Diameters — The main bars in the slab shall not be less than 8 mm (high yield strength bars) or 10 mm (plain bars) and distribution steel shall not be less than 6 mm diameter bars. The diameter of the bar shall not also be more than one-eighth of the slab thickness.

9.3 Simply Supported Slabs

9.3.1 Slabs Spanning in One Direction — A slab that is supported on two opposite sides only by either walls or beams is said to be spanning in one direction. The slab is considered as spanning in one direction even when the slab is supported on all four sides if the effective length of the slab exceeds two times its effective width. The shorter span is to be considered for design.

Figure 9.1 shows the general details of slab spanning in one direction. It clearly indicates the size and thickness of the slab and reinforcement, the cover and the spacing. Slab thickness shall be indicated both in plan and section. Where series of identical bars are used, it is customary to show only one bar. The bars in the shorter direction (main bars) are placed in the bottom layer. At least 50 percent of main reinforcement provided at mid span should extend to the supports. The remaining 50 percent should extend to within 0.1 l of the support.

The bars in longer direction of the slab are called distribution or transverse steel. These assist in distribution of the stresses caused by the superimposed loading, temperature changes and shrinkage during the hardening process. These bars are placed in the upper layer and tied with the main steel bars to keep them in correct position during concreting.

9.3.2 Slabs Spanning in Two Directions — A simple slab spanning in two directions ($l_y/l_x \leq 2$) and supported on four brick walls is shown in Fig. 9.2.

As the slab is spanning in both directions the reinforcement in each direction shall be considered as main reinforcement. The bars in the shorter direction are generally placed in the bottom layer and tied with the bars in the longer direction placed above at suitable intervals to keep their relative positions intact during concreting.

At least 50 percent of the tension reinforcement provided at mid-span should extend to the supports. The remaining 50 percent should extend to within 0.1 l_x or 0.1 l_y of the support, as appropriate, where l_x and l_y are effective spans in the shorter direction and longer direction, respectively.

9.4 Restrained Slabs — When the corners of a slab are prevented from lifting, the following simplified detailing rules may be applied, provided the slab is designed for predominantly uniformly distributed loads.

NOTE 1 — The analysis of uniformly distributed load and concentrated loads may be done separately, and with appropriate theories. The reinforcement quantities determined in this way should be superimposed.

NOTE 2 — If an end support is assumed to be a free support in the analysis, but if the character of the structure is such that restraint may nevertheless occur at the support, a restraint moment equal to half the mid-span moment in the strip concerned may be adopted.

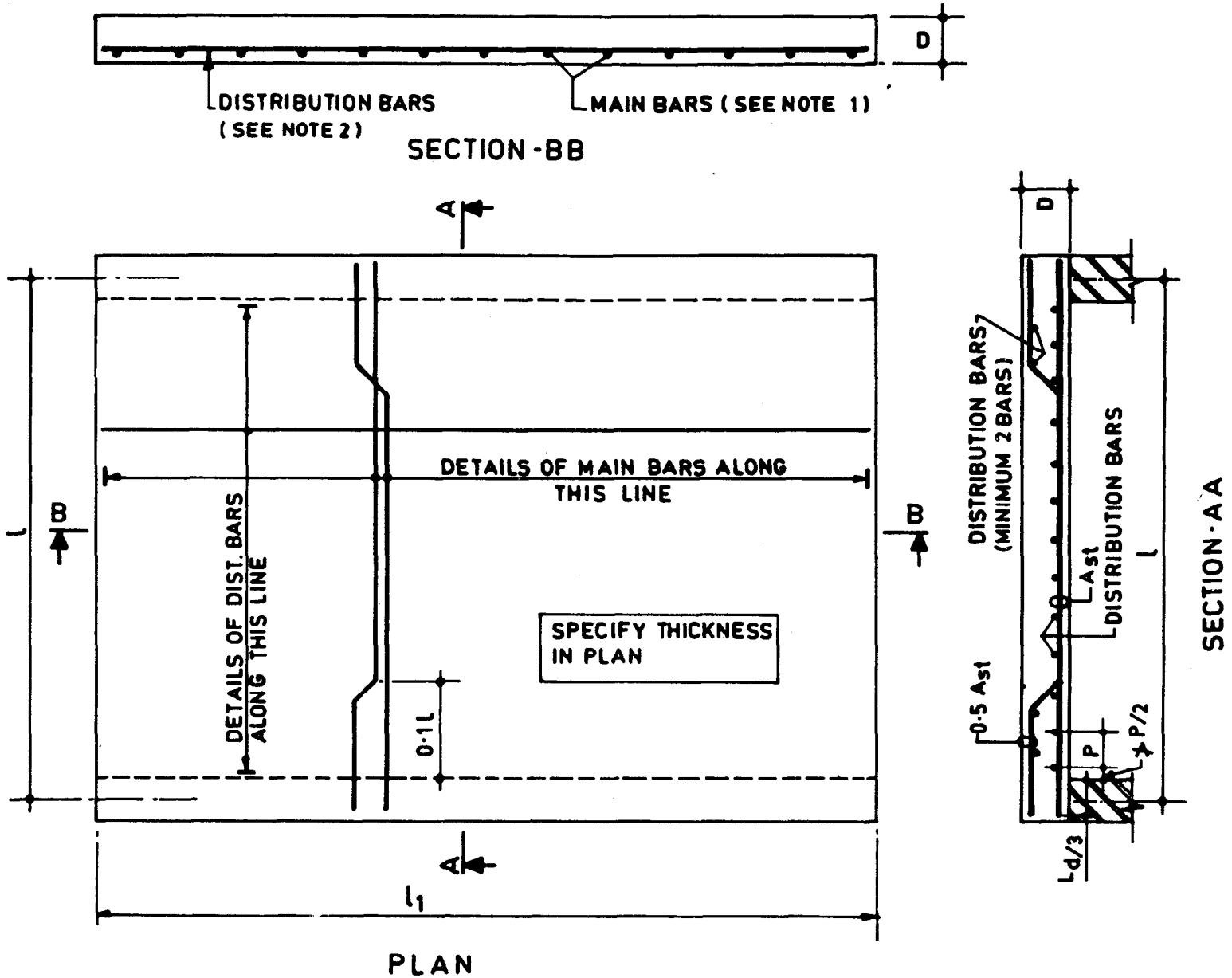

NOTE 1 — Diameter \leq 8 mm for deformed bars; 10 mm for plain bars; Spacing \geq 3d or 450 mm

NOTE 2 — Diameter \leq 6 mm; Spacing \geq 5d or 450 mm

FIG. 9.1 TYPICAL DETAILS OF A SLAB SPANNING IN ONE DIRECTION

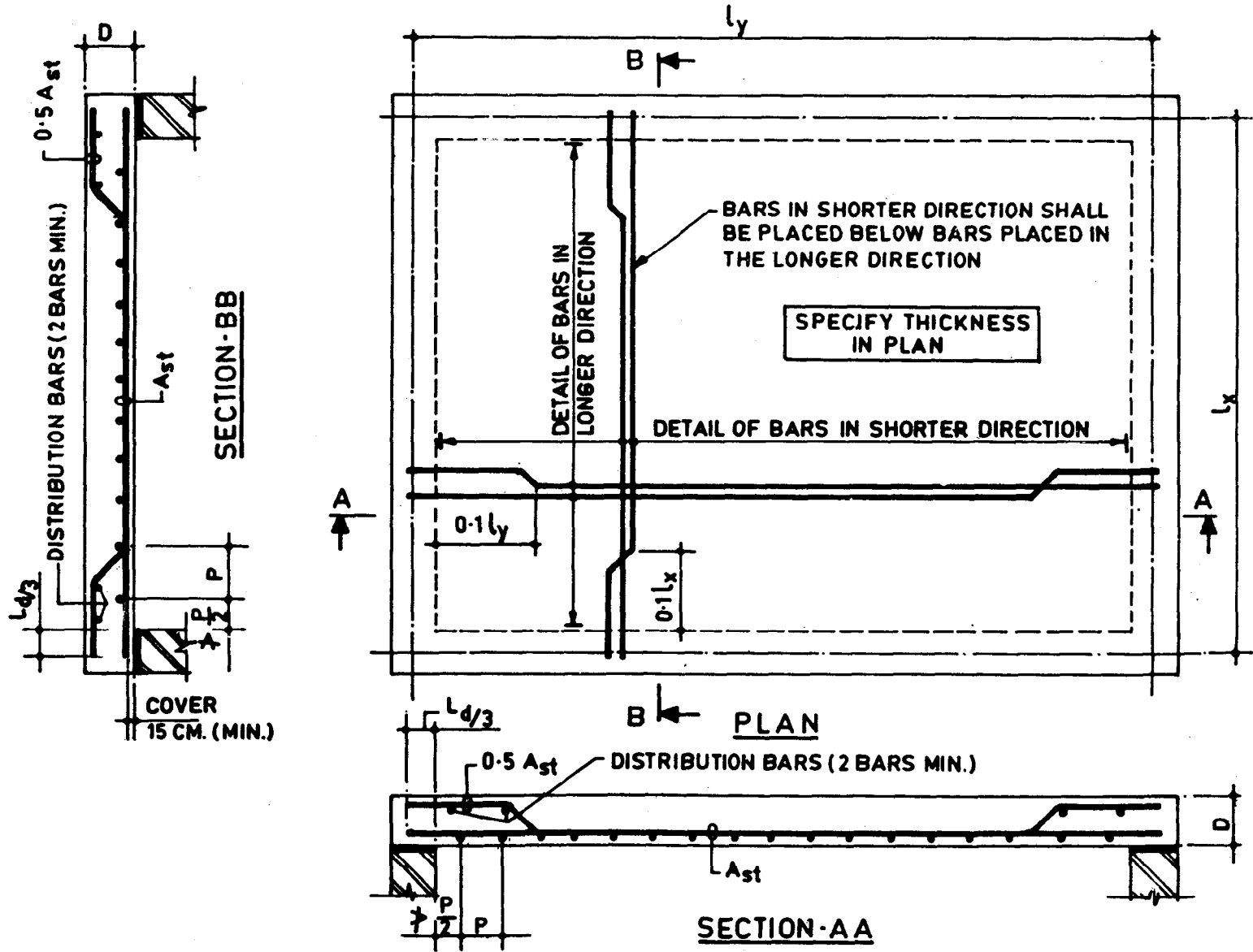

FIG. 9.2 TYPICAL DETAILS OF A SLAB SPANNING IN TWO DIRECTIONS

9.4.1 The slabs are considered as divided in each direction into middle strips and edge strips as shown in Fig. 9.3, the middle strip being three-quarters of the width and each edge strip one-eighth of the width.

9.4.2 The tension reinforcement provided at mid-span in the middle strip shall extend in the lower part of the slab to within $0.25 l$ of a continuous edge, or $0.15 l$ of a discontinuous edge.

9.4.3 Over the continuous edges of a middle strip, the tension reinforcement shall extend in the upper part of the slab a distance of $0.15 l$ from the support, and at least 50 percent shall extend a distance of $0.30 l$.

9.4.4 At a discontinuous edge, negative moments may arise. They depend on the fixity at the edge of the slab but, in general, tension reinforcement equal to 50 percent of that provided at mid-span extending $0.1 l$ into the span will be sufficient.

9.4.5 Reinforcement in edge strip parallel to the edge, shall comply with the minimum reinforcement requirement (9.1) and the requirements for torsion in 9.4.6. to 9.4.6.2.

9.4.6 Torsional Reinforcement—Torsional reinforcement shall be provided at any corner where the slab is simply supported on both edges meeting at that corner and is prevented from lifting unless the consequences of cracking are negligible. It shall consist of top and bottom reinforcement, each with layer of bars placed parallel to the sides of the slab and extending from the edges a minimum distance of one-fifth of the shorter span. The area of reinforcement per unit width in each of these four layers shall be three-quarters of the area required for the maximum mid-span moment per unit width in the slab (see Fig. 9.4A).

9.4.6.1 Torsional reinforcement equal to half that described in 9.4.6 shall be provided at a corner contained by edges over only one of which the slab is continuous. (see Fig. 9.4B.)

9.4.6.2 Torsional reinforcement need not be provided at any corner contained by edges over both of which the slab is continuous.

9.4.7 A slab shall be treated as spanning one way (in the shorter direction) when ratio of effective span in the longer direction to the effective span in the shorter direction is greater than 2.

9.4.8 Figure 9.5 illustrates curtailment of bars in a restrained slab spanning in two directions based on the above rules using straight bars or bent-up bars.

9.4.9 Re-entrant Corners—Diagonal reinforcement shall be placed at all re-entrant corners to keep crack widths within limits (see Fig. 9.6).

9.5 Cantilever Slabs—The main reinforcement shall be placed in the top of cantilever slab extending to sufficient length over the support and back into the normal span. The method of curtailment shall conform to the requirements specified in Section 4.

Support to the top steel of cantilever slabs at spacings (for stools and chairs) should preferably be specified in the detailing drawing. The bending of the main bars should be such that they contribute to the supporting of the steel, that is, bars that extend to the end should have vertical bends, with a fixing bar at the bend.

The secondary steel at right angles to the support may be designed and detailed to carry construction loading in the propped condition, if necessary.

The deflection in cantilever slabs can be reduced by the addition of compression steel at the bottom. This would also be helpful in counteracting possible reversal of bending moments.

9.5.1 The simplified curtailment rules illustrated in Fig. 9.7 may be used for cantilever slabs when they are designed for predominantly uniformly distributed loads.

9.5.2 Tie Backs and Counter Masses to Cantilevers

9.5.2.1 Cantilever at the bottom of beams—Ensure, when a cantilever is at the bottom of a beam, the design of the stirrups in the beam provides for moment, shear, hanging tension and, if necessary, torsion. If possible, provide in the detailing of this steel for placing of the beam steel without the necessity of the threading of the main beam steel through the cantilever anchorage loops. The details should conform to the basic principles applicable to opening corner in retaining walls and the beams. Figure 9.8 provides three alternative methods of anchoring bars in supporting beams.

NOTE—Note the special difficulty induced by bent-up bars in the beam steel:

- a) Curtailed bars going to the back of a beam may drift out of position during casting of concrete.
- b) Hairpin type bars should be related to the horizontal stirrup spacing, and this may cause difficulties.
- c) Loops of 270° are difficult to bend and place in position.

9.5.2.2 Cantilever at the top of beams—Where the weathering course is 30 mm or less, crank the bars at a slope not exceeding 1 in 6 [see Fig. 9.9(A)]. Ensure that the combination of top bars and stirrups is such as to provide the required restraint. Note that if a bar is laced over and under the beam bars, it is fully restrained provided that the beam top bars are heavy enough and a stirrup is within 50 mm of such bar. If the bar is not so laced, detail the steel to ensure the anchorage against bursting (see Fig. 9.9).

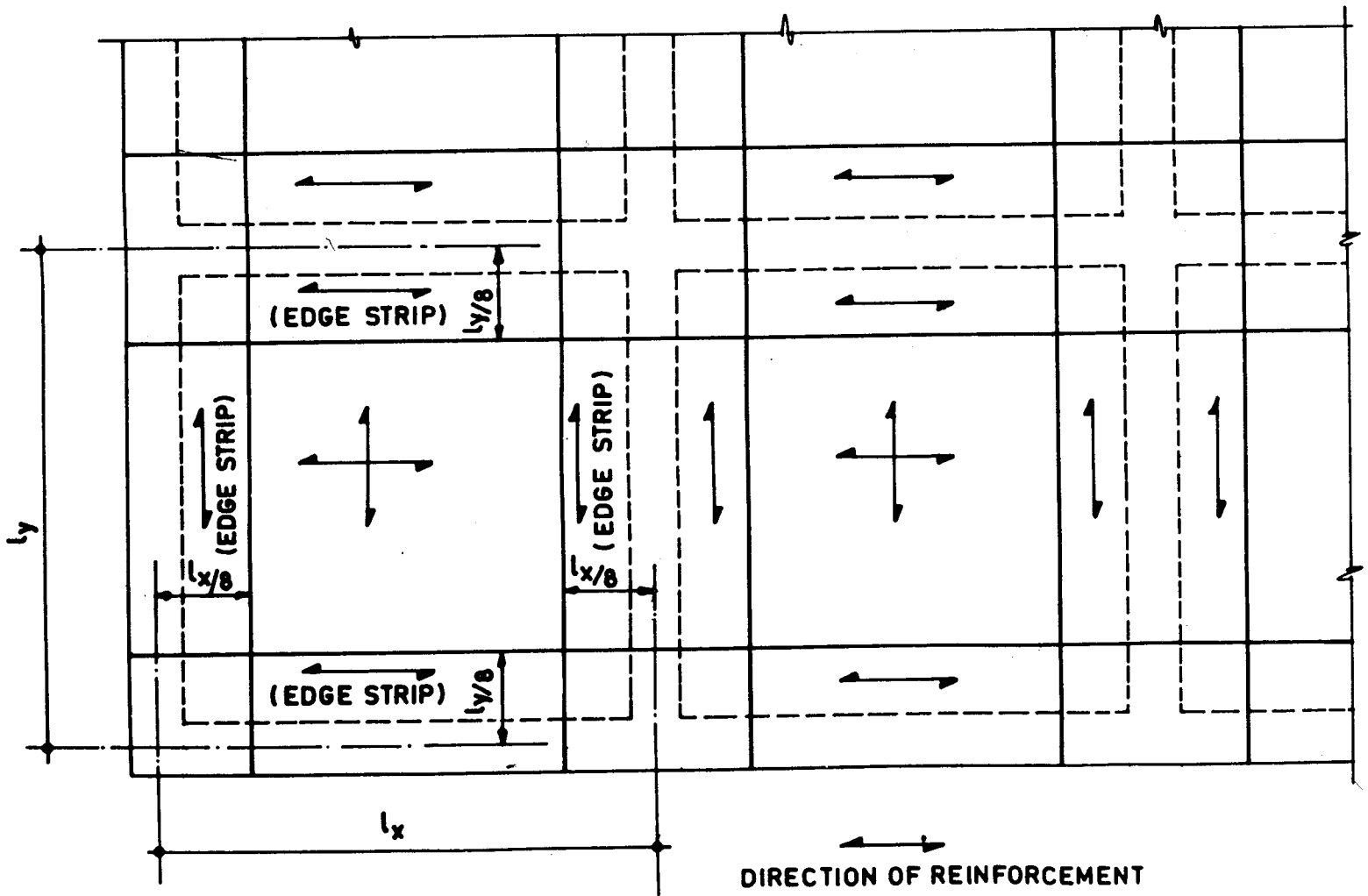
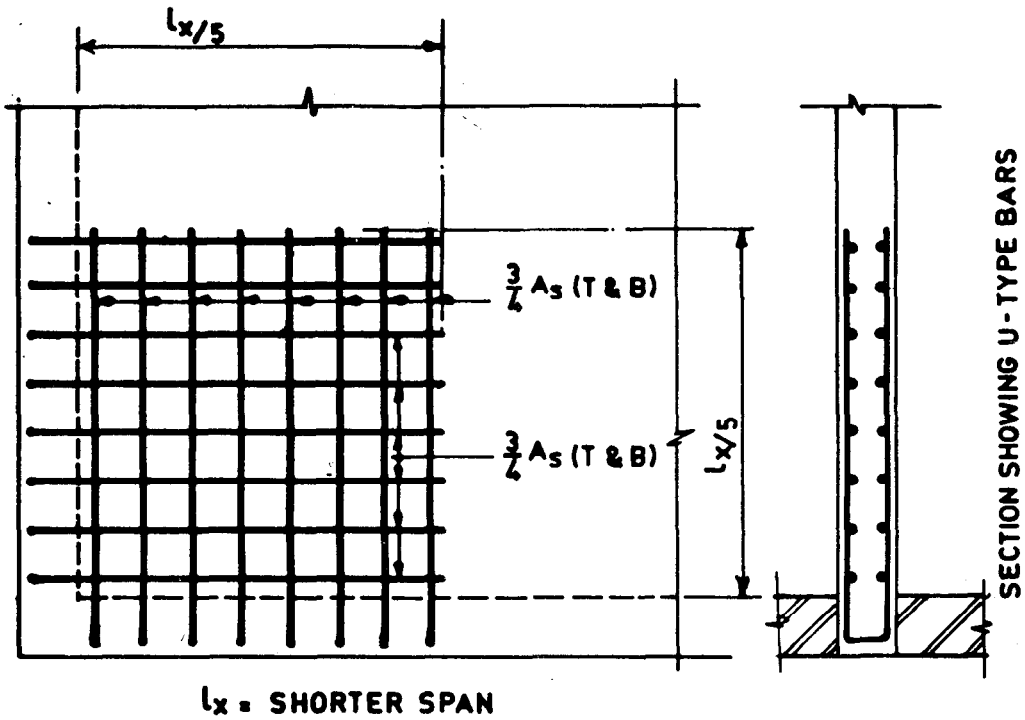
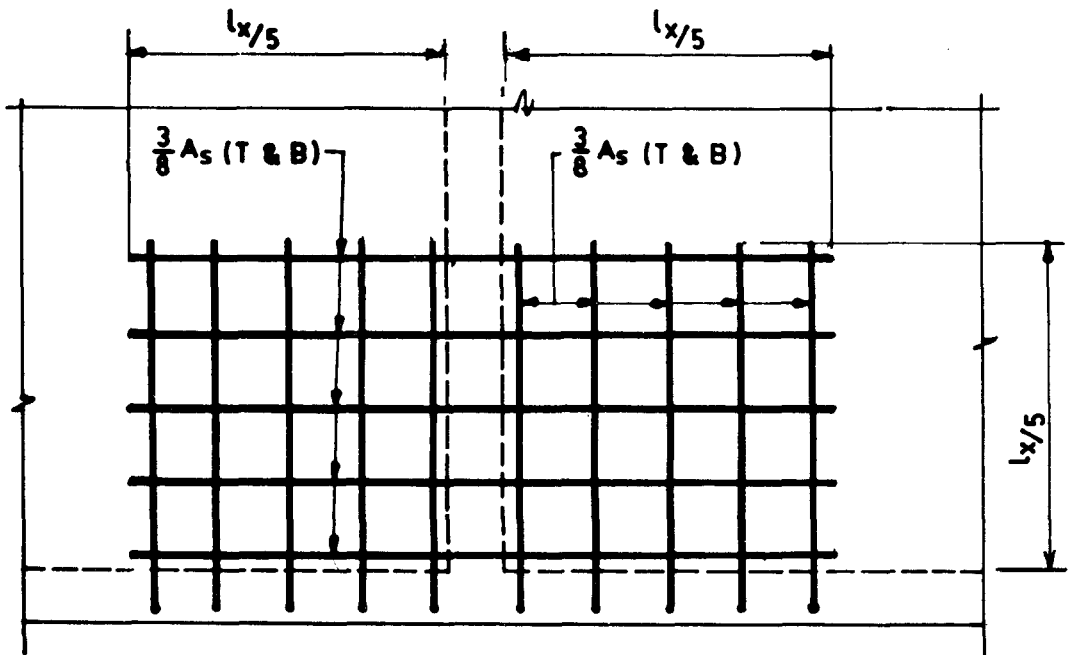

FIG. 9.3 SLAB SPANNING IN TWO DIRECTIONS—ARRANGEMENT OF STRIPS AND DIRECTION OF REINFORCEMENT



9.4A Corner with Two Discontinuous Ends



9.4B Corner with One Discontinuous Ends

FIG. 9.4 TORSIONAL REINFORCEMENT IN SLABS

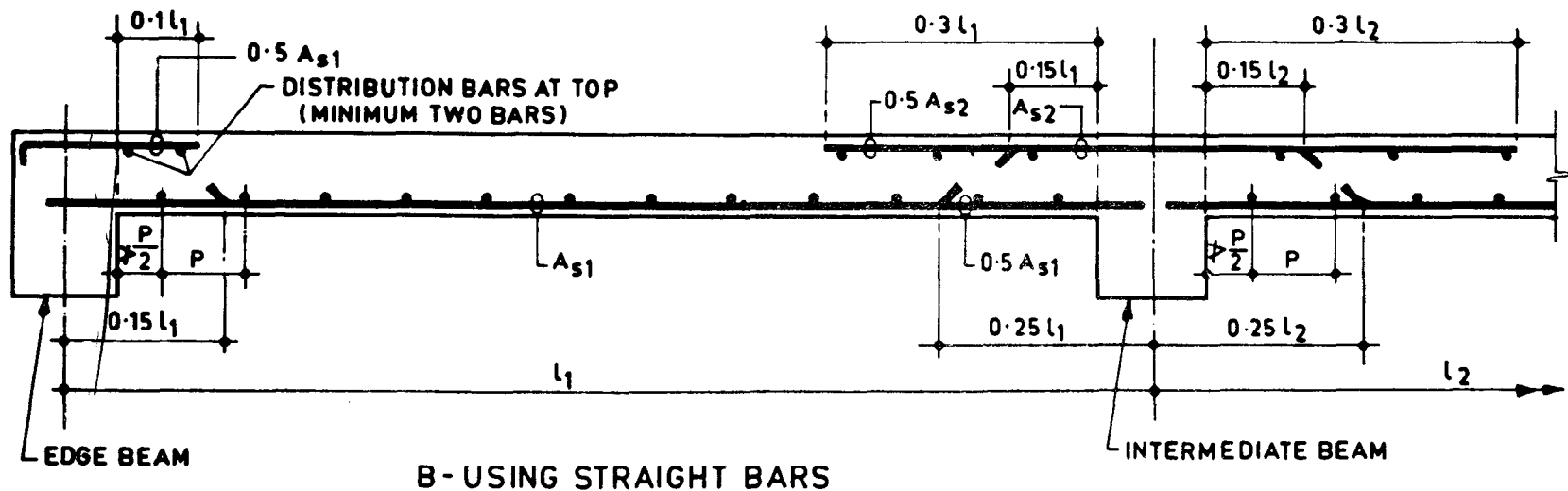
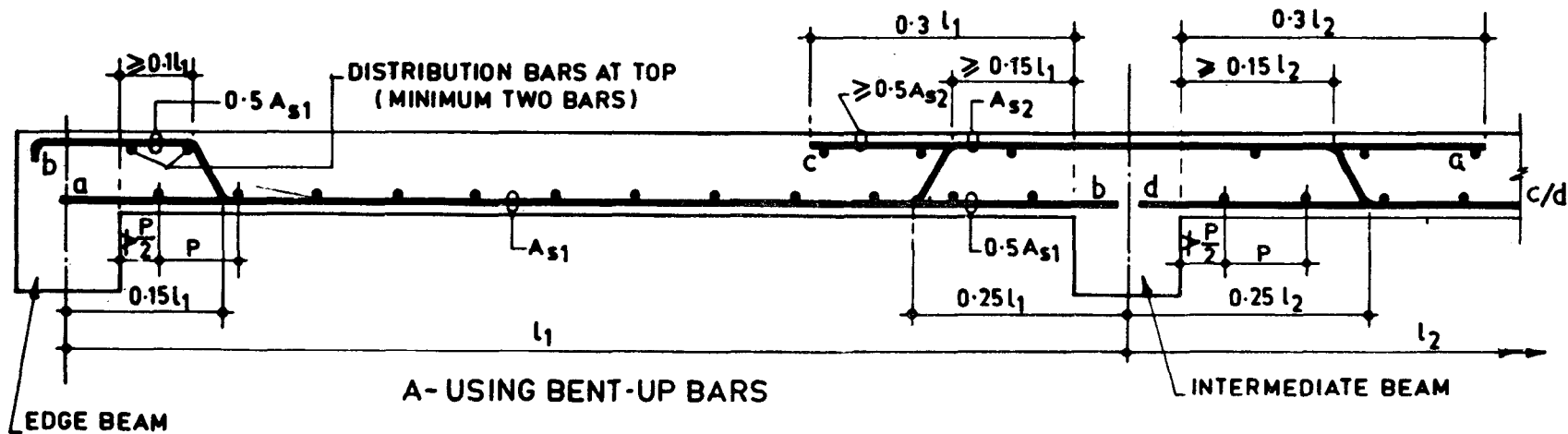

FIG. 9.5 SIMPLIFIED RULES FOR CURTAILMENT OF BARS—SECTION THROUGH MIDDLE STRIP

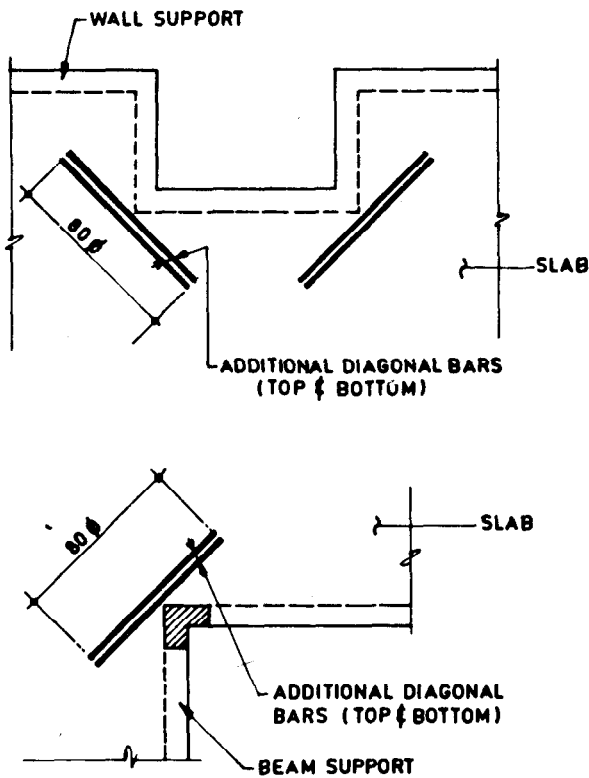

FIG. 9.6 ADDITIONAL REINFORCEMENT AT RE-ENTRANT CORNERS

9.5.3 Cantilevers Around Corners — Ensure that, in a corner of a cantilever slab, the detailing is such that tie-back loading and the deflections that arise from this are accounted for. Avoid 'fan' type detailing. Take particular care with drainage inlets.

9.6 Openings in Slab: — Special detailing for openings for lift shafts, large service ducts, etc, in the floors shall be given in the drawing. Such openings shall be strengthened by special beams or additional reinforcement around the openings. Due regard shall be paid to the possibility of diagonal cracks developing at the corners of the openings.

NOTE — The number, size and position of trimming bars is a function of the design, and should be determined by the designer.

9.6.1 Where openings are small and the slab is not subjected to any special type loading or vibration conditions, the following general detailing rules may be followed around openings (see Fig. 9.10 and 9.11):

- a) At least one half the quantity of principal steel intersected by the opening is to be placed parallel to principal steel on each side of the opening extending L_d beyond the edges of the opening.
- b) Diagonal stitching bars are put across the corners of rectangular holes or so placed as

to frame circular openings. They should be placed both at top and bottom if the thickness of slab exceeds 150 mm. The diameter of these bars should be the same as that of the larger of the slab bars, and their length should be about 80 diameters.

NOTE — In general openings of diameter less than 250 mm or of size smaller than 200 × 200 mm may be treated as insignificant openings.

9.7 Slabs with Welded Wire Fabric

9.7.1 General — Welded wire fabric is either oblong mesh or square mesh and is supplied in either rolls or flat sheets. The details regarding material, types and designation, dimensions, sizes of sheets or rolls, weight, tolerance, mechanical properties, etc, are all covered in IS : 1566-1982 'Specification for hard-drawn steel wire fabric for concrete reinforcement (second revision)' (see also Section 1).

9.7.2 Detailing

9.7.2.1 To ensure that correct size of fabric is laid in right direction, small sketches should be inserted on the plan to indicate the direction of span of the fabric. Details at A and B in Fig. 9.12 indicate square and oblong welded wire fabric, respectively, in plan view of slab.

9.7.2.2 The actual position of the welded wire fabric sheet in slab panels may be shown by a diagonal line together with the description of the mesh used. Bottom sheets should be shown with diagonal drawn from bottom left-hand corner to the top right-hand corner. Top sheets should be shown from top left-hand corner to the bottom right-hand corner. A schedule may also be included in the structural drawing indicating the mesh sizes, length and width, and cutting details for welded wire fabric sheets for different slabs panels. A typical plan is illustrated in Fig. 9.13 (see Section 5 for schedule).

9.8 Flat Slabs

9.8.1 General — The term flat slab means a reinforced concrete slab with or without drops, supported generally without beams, by columns with or without flared column heads (see Fig. 9.14). A flat slab may be solid slab or may have recesses formed on the soffit so that the soffit comprises a series of ribs (waffles) in two directions. The recesses may be formed by removable or permanent filler blocks.

9.8.1.1 (see Fig. 9.15)

- a) **Column strip** — Column strip means a design strip having a width of $0.25 l_2$, but not greater than $0.25 l_1$ on each side of the column centre line, where l_1 is the span in the direction moments are being determined, measured centre-to-centre of supports and l_2 is the span transverse to l_1 , measured centre-to-centre of supports.

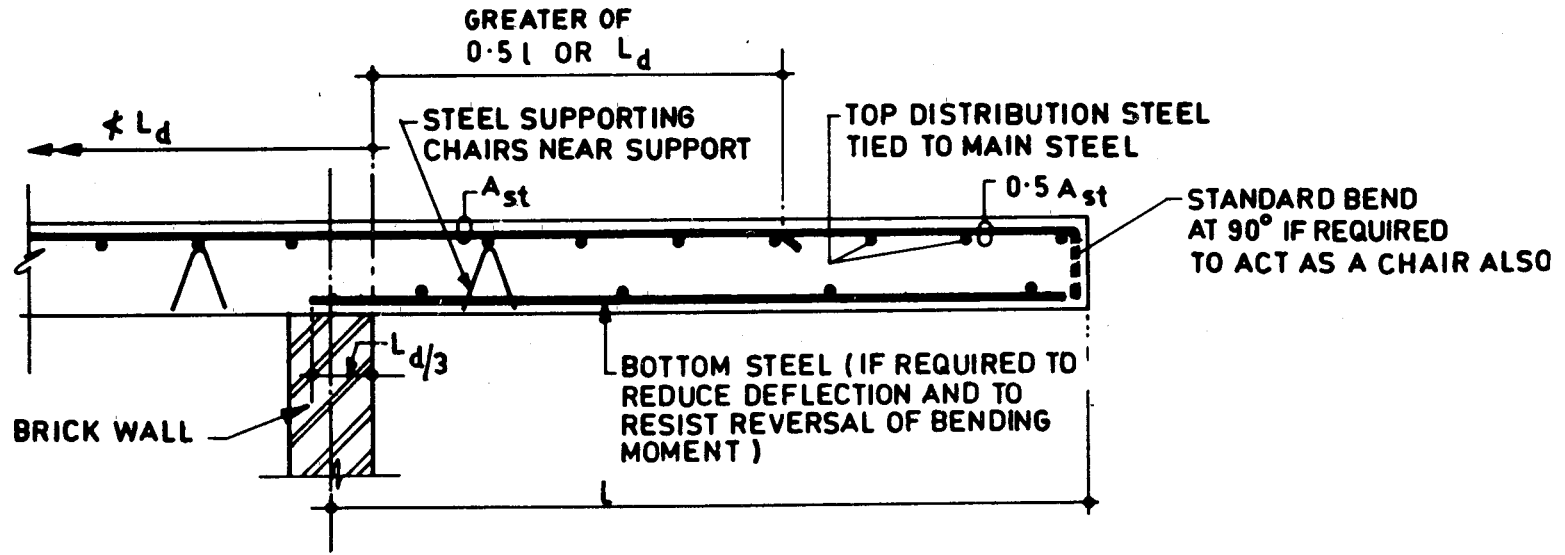

9.7A CANTILEVER SLAB CONTINUOUS OVER A BRICK WALL

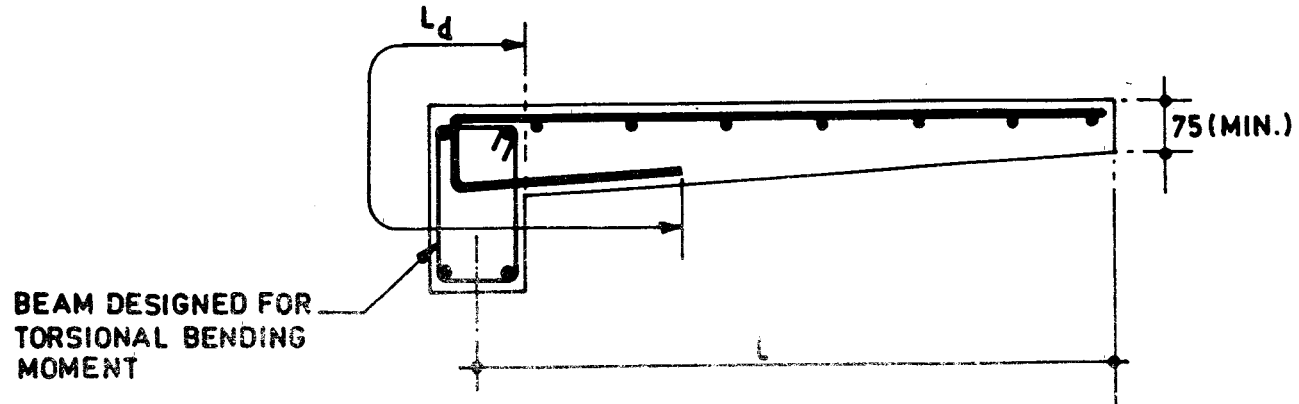

9.7B SLAB CANTILEVERING FROM A BEAM

FIG. 9.7 CANTILEVER SLAB

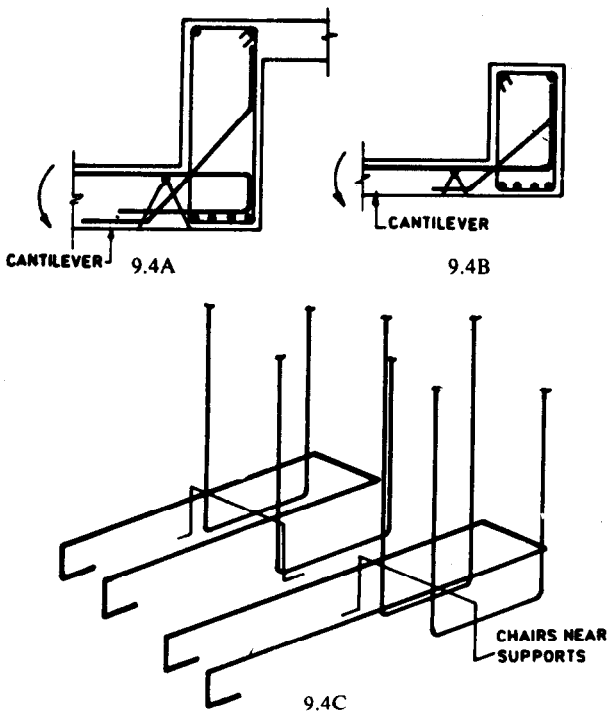

NOTE — Bottom bars left out for clarity

FIG. 9.8 CANTILEVER SLABS AT THE BOTTOM OF BEAMS

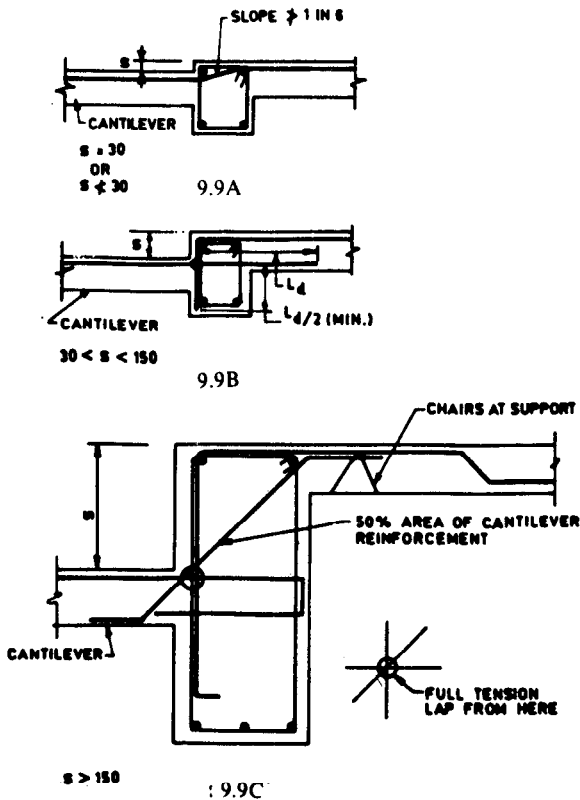

NOTE — Bottom bars left out for clarity

FIG. 9.9 CANTILEVER AT THE TOP OF BEAMS

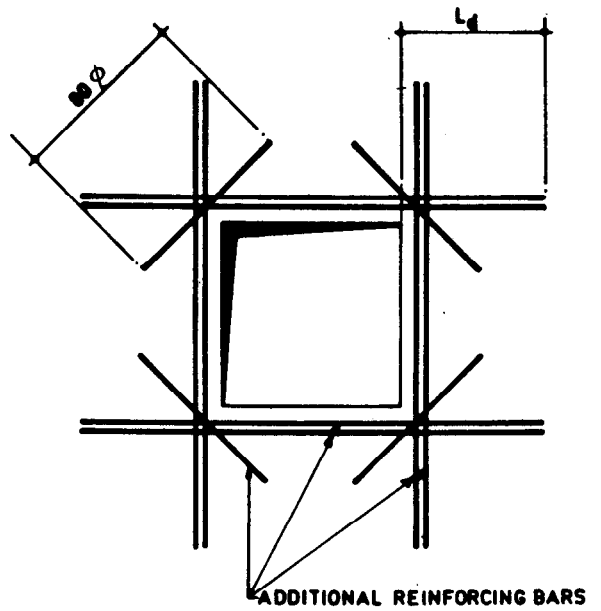

FIG. 9.10 ADDITIONAL REINFORCEMENT AROUND A RECTANGULAR A OPENING IN A SLAB

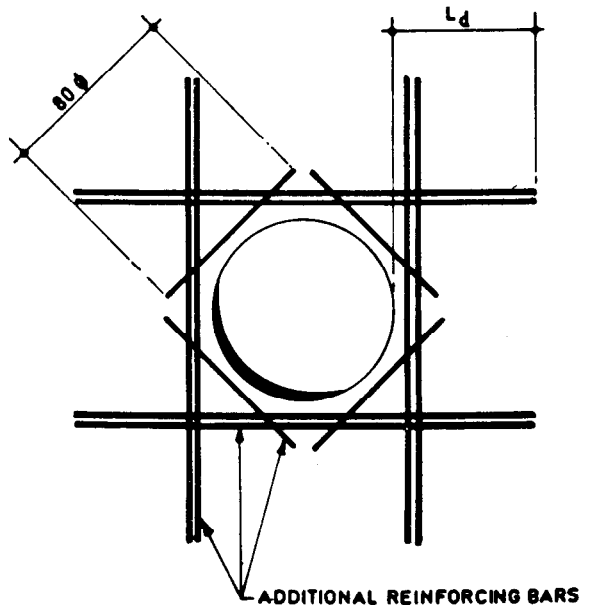

FIG. 9.11 ADDITIONAL REINFORCEMENT AROUND A CIRCULAR OPENING IN A SLAB

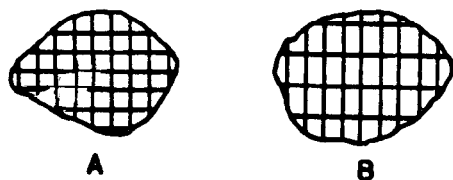

FIG. 9.12 WELDED WIRE FABRIC IN PLAN VIEW OF SLAB.

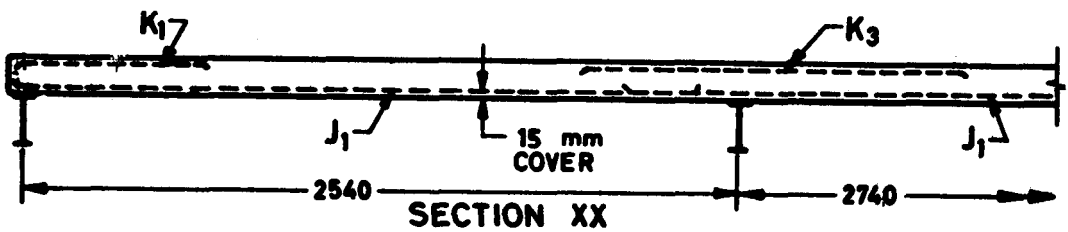
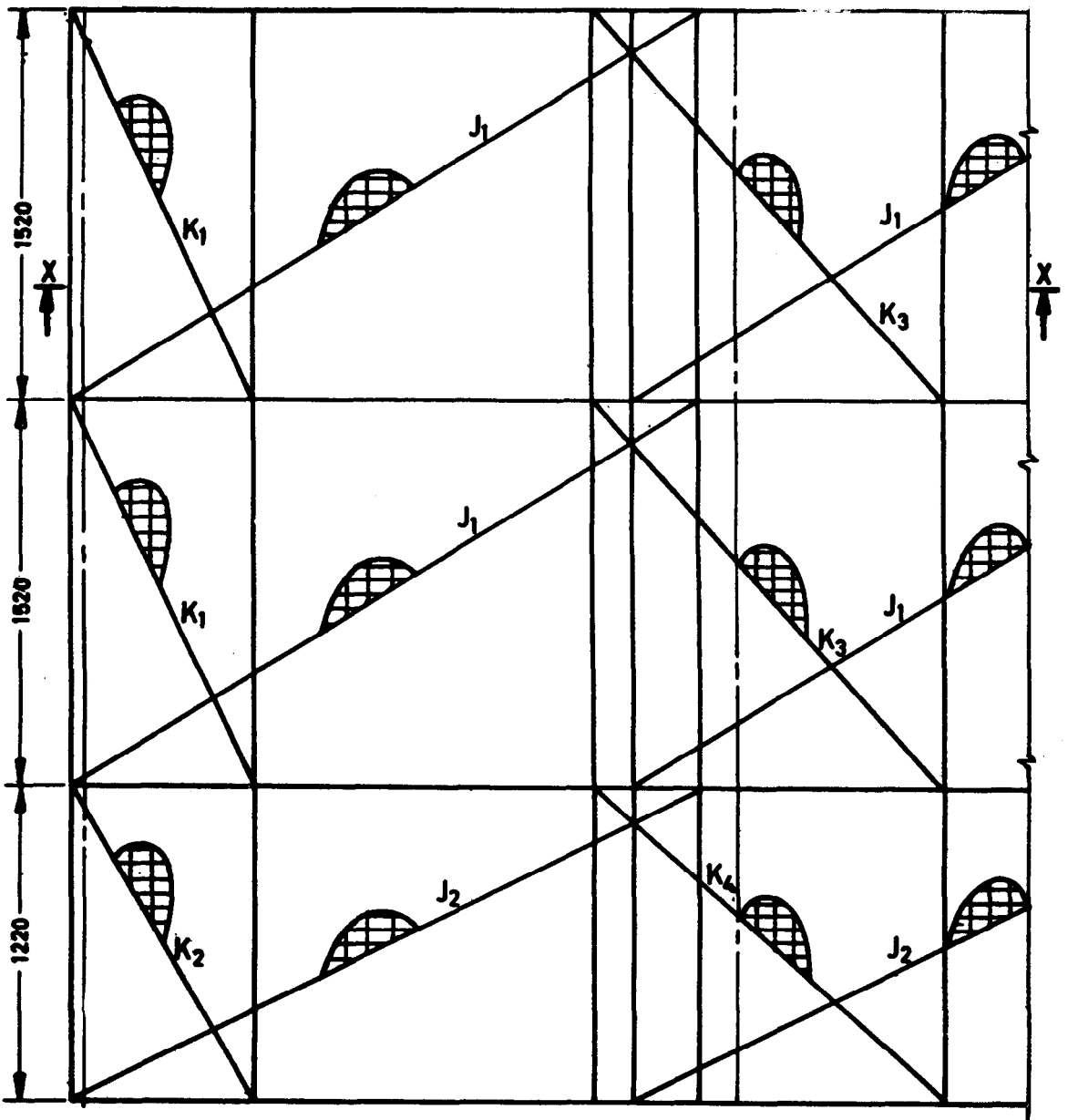
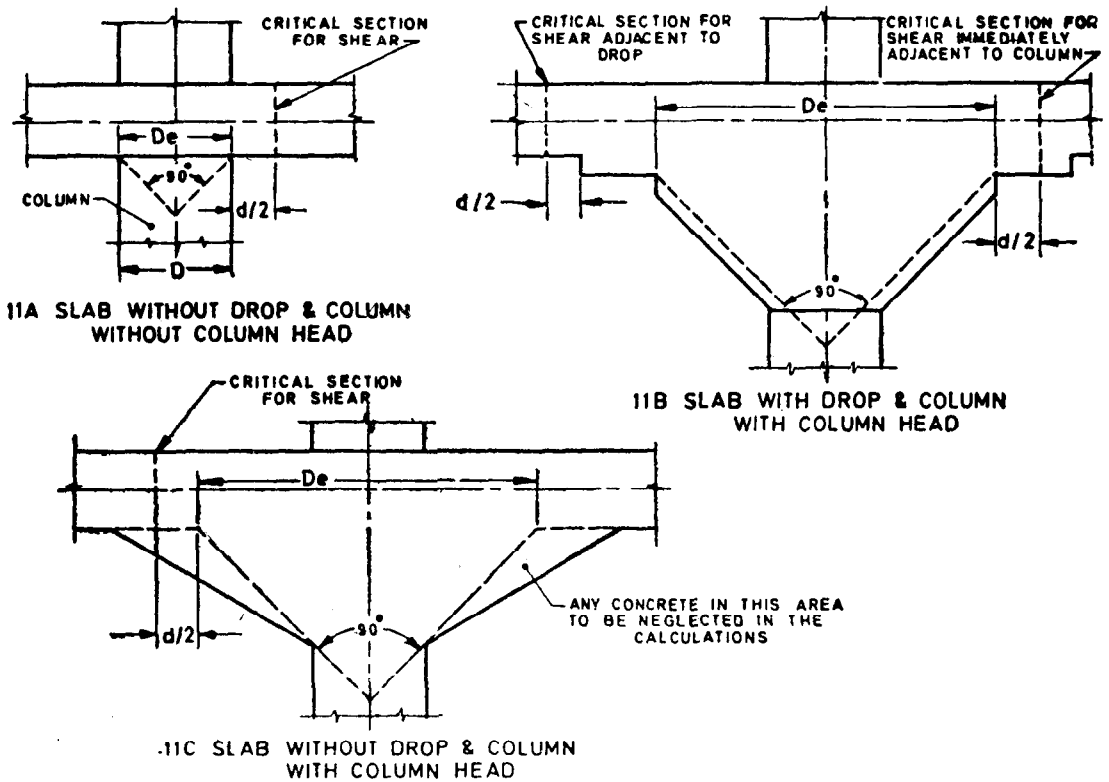

FIG. 9.13 PLAN SHOWING TYPICAL DETAILS OF WELDED WIRE FABRIC



NOTE — D_e is the diameter of column or column head to be considered for design and d is effective depth of slab or drop as appropriate.

FIG. 9.14 CRITICAL SECTIONS FOR SHEAR IN FLAT SLABS

- b) *Middle strip* — Middle strip means a design strip bounded on each of its opposite sides by the column strip.
- c) *Panel* — Panel means that part of a slab bounded on each of its four sides by the centre line of a column or centre line of adjacent spans.

9.8.2 Proportioning

9.8.2.1 The minimum thickness of slab shall be 125 mm.

9.8.2.2 *Drops* — The drops, when provided, shall be rectangular in plan and have a length in each direction not less than one-third of the panel length in that direction. For exterior panels, the width of drops at right angles to the non-continuous edge and measured from the centre line of the columns shall be equal to one-half the width of drop for interior panels.

9.8.2.3 *Column heads* — Where column heads are provided, that portion of a column head which lies within the largest right circular cone or pyramid that has a vertex angle of 90° and can be included entirely within the outlines of the column and the column head, shall be considered for design purposes (see 9.13).

9.8.3 Slab Reinforcement

9.8.3.1 *Spacing* — The spacing of bars in a flat slab shall not exceed twice the slab thickness, except where a slab is of cellular or ribbed construction.

9.8.3.2 *Area of reinforcement* — When drop panels are used, the thickness of drop panel for determination of area of reinforcement shall be the lesser of the following:

- a) Thickness of drop, and
- b) Thickness of slab plus one-quarter the distance between edge of drop and edge of capital.

9.8.3.3 *Minimum length of reinforcement*

- a) Reinforcement in flat slabs shall have the minimum lengths specified in Fig. 9.16. Larger lengths of reinforcement shall be provided when required by analysis.
- b) Where adjacent spans are unequal, the extension of negative reinforcement beyond each face of the common column shall be based on the longer span.

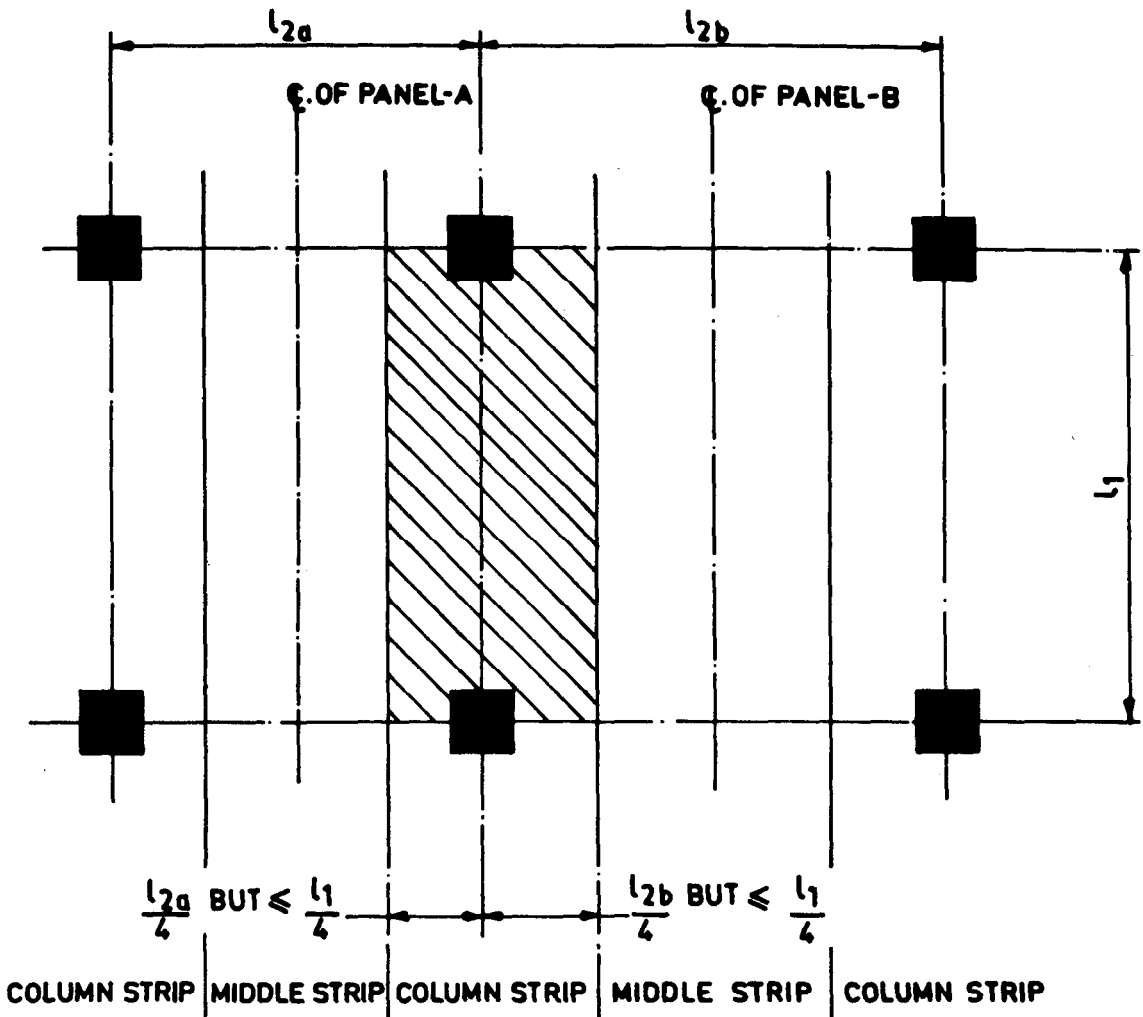

FIG. 9.15 PANELS, COLUMN STRIPS AND MIDDLE STRIPS

9.8.3.4 Anchoring reinforcement

- a) All slab reinforcement perpendicular to a discontinuous edge shall have an anchorage (straight, bent or otherwise anchored) past the internal face of the spandrel beam, wall or column of an amount:
- 1) for positive reinforcement — not less than 15 cm except that with fabric reinforcement having a fully welded transverse wire directly over the support, it shall be permissible to reduce this length to one-half of the width of the support or 5 cm, whichever is greater; and
 - 2) for negative reinforcement — such that the design stress is developed at the internal face, in accordance with Section 4.
- b) Where the slab is not supported by a spandrel beam or wall, or where the slab cantilevers beyond the support, the anchorage shall be obtained within the slab.

9.8.3.5 When the design is based on the direct design method specified in IS : 456-1978, simplified detailing rules as specified in Fig. 9.17 may be followed. A typical arrangement of bars in a flat slab with drop panels is shown in Fig. 9.17.

9.8.4 Openings in Flat Slabs — Openings of any size may be provided in the flat slab if it is shown by analysis that the requirements of strength and serviceability are met. However, for openings conforming to the following, no special analysis is required (see also 9.6):

- a) Openings of any size may be placed within the middle half of the span in each direction, provided the total amount of reinforcement required for the panel without the opening is maintained.
- b) In the area common to two column strips, not more than one-eighth of the width of strip in either span shall be interrupted by the openings. The equivalent of reinforcement

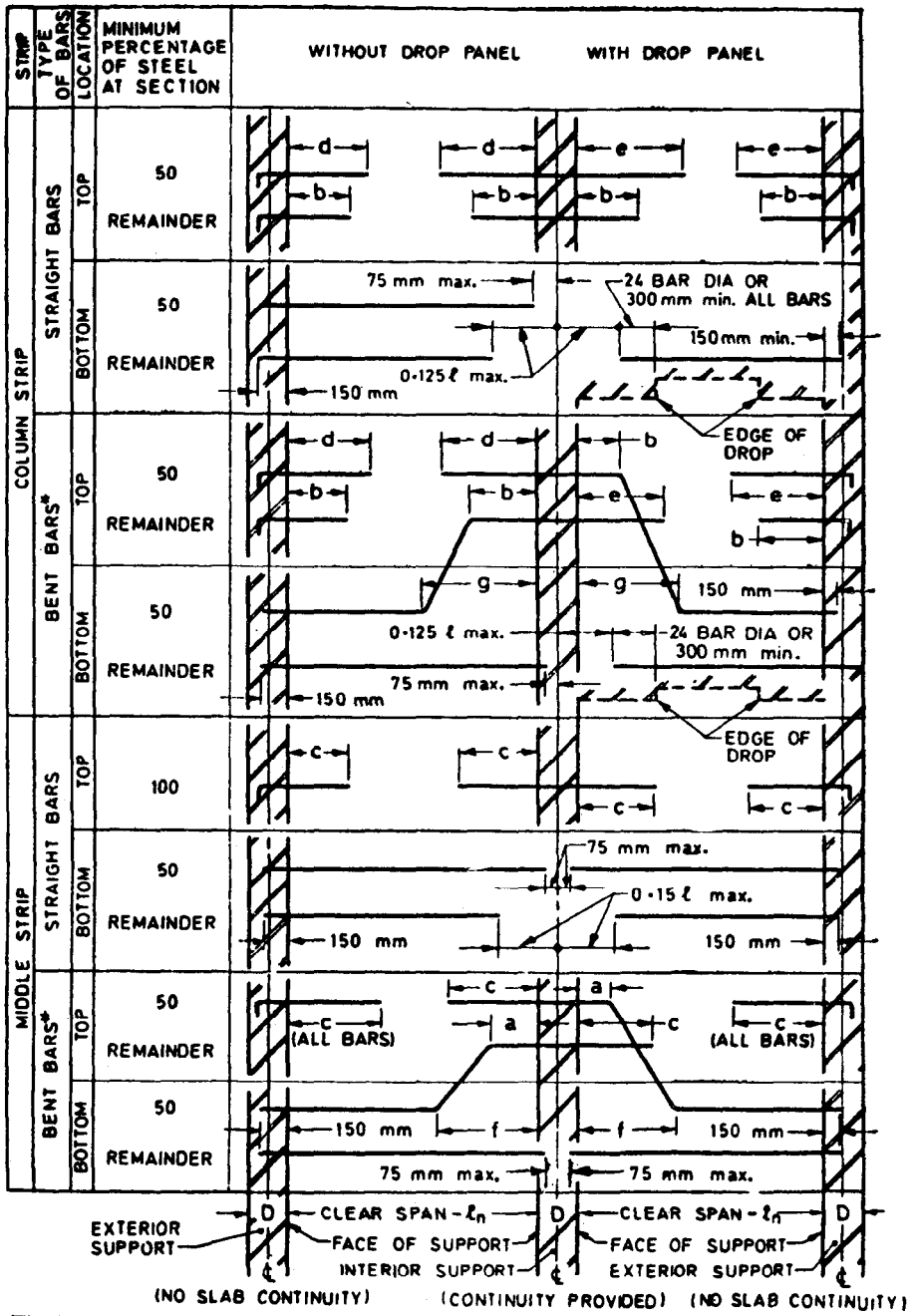

| BAR LENGTH FROM FACE OF SUPPORT | | | | | | | |
|---------------------------------|---------------|---------------|---------------|---------------|---------------|---------------|----------------|
| Minimum Length | | | | | | | Maximum Length |
| Mark | a | b | c | d | e | f | g |
| Length | $0.14 \ell_n$ | $0.20 \ell_n$ | $0.22 \ell_n$ | $0.30 \ell_n$ | $0.33 \ell_n$ | $0.20 \ell_n$ | $0.24 \ell_n$ |

Bent bars at exterior supports may be used if a general analysis is made.

NOTE - D is the diameter of the column and the dimension of the rectangular column in the direction under consideration.

FIG. 9.16

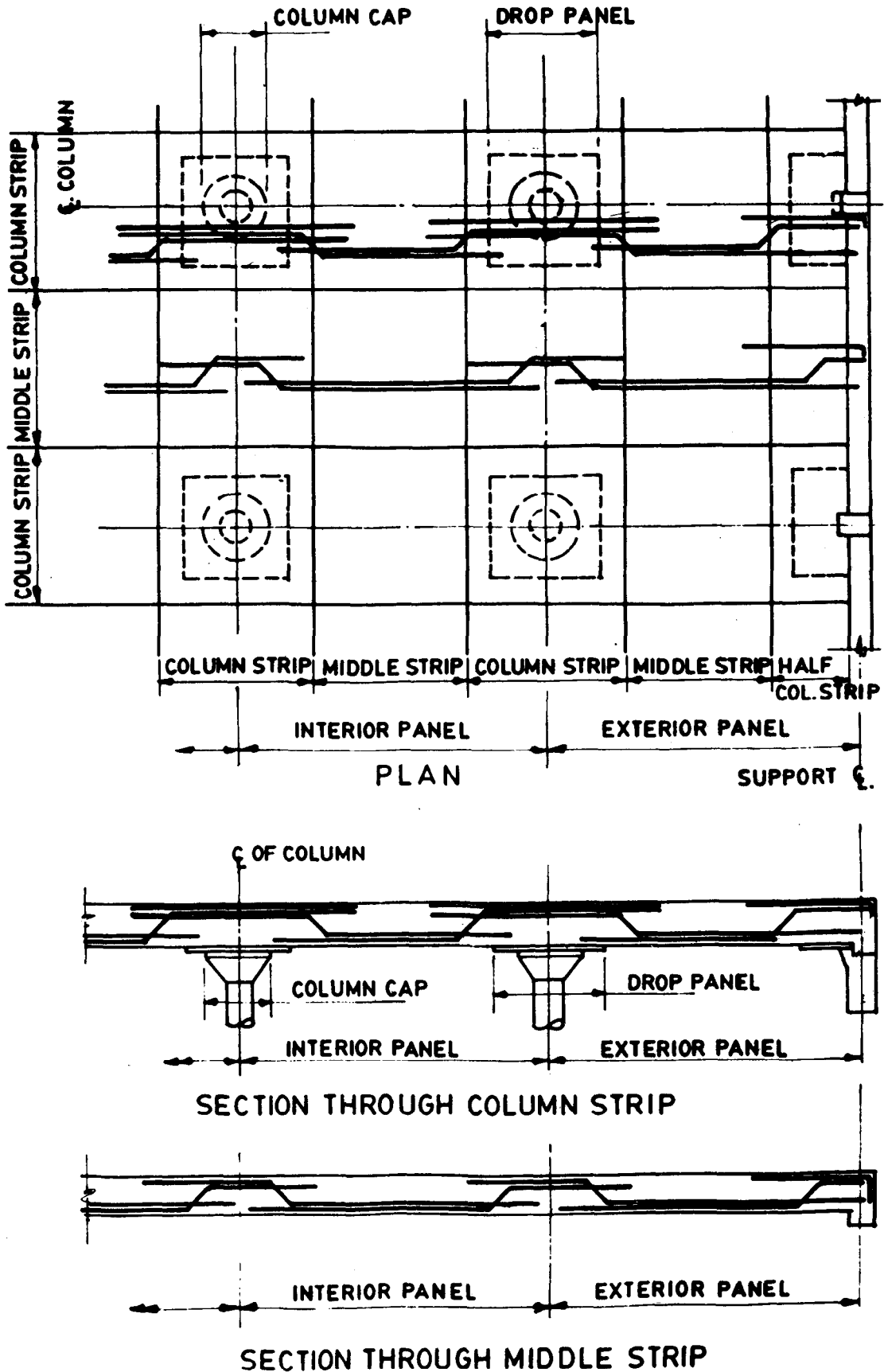

FIG. 9.17 TYPICAL ARRANGEMENT OF BARS IN A FLAT SLAB WITH DROP PANELS

interrupted shall be added on all sides of the openings.

- c) In the area common to one column strip and one middle strip, not more than one-quarter of the reinforcement in either strip shall be interrupted by the openings. The equivalent of reinforcement interrupted shall be added on all sides of the openings.

9.8.5 Shear Reinforcement at Column Heads and Dropped Panels — The best method of providing shear reinforcement for slabs at column heads is to use beam cages in one direction and bars in the other direction laid under and on top of the steel in the cages (see Fig. 9.18). Other methods such as the following may also be used depending upon their suitability:

- a) Half or open stirrups suspended from the top steel;
- b) Use of serpentine bars (see Fig. 9.19A).
- c) Spiders made of bent bars (for deep slabs) (see Fig. 9.19B).
- d) Structural steel frames made of plate.

A few more methods of detailing shear reinforcement in flat slabs are given in Fig. 9.20 to 9.22.

9.9 Waffle Slabs

9.9.1 Definition — A waffle flat slab is a two-way joist system. The two-way joist portion may be combined with a solid column head or with solid wide beam sections on the column centre lines for uniform depth construction.

9.9.2 Size of Waffles — Re-usable forms of standard size shall be used for economy. These shall provide the width of rib at least 10 cm and spaced not more than 100 cm clear, and depth not more than $3\frac{1}{2}$ times the minimum width. Standard size may be adopted for these moulds as 50×50 cm, 60×60 cm, 80×80 cm, and 100×100 cm and depth as 15, 20, 25, 30, 35, 40, 45, and 50 cm.

9.9.3 Detailing of Reinforcement in the Waffle Slab (With Solid Head and Square Interior Panel) — Ensure that at least 50 percent of the total main tension steel in the ribs is carried through at the bottom on to the support and anchored (see Fig. 9.23).

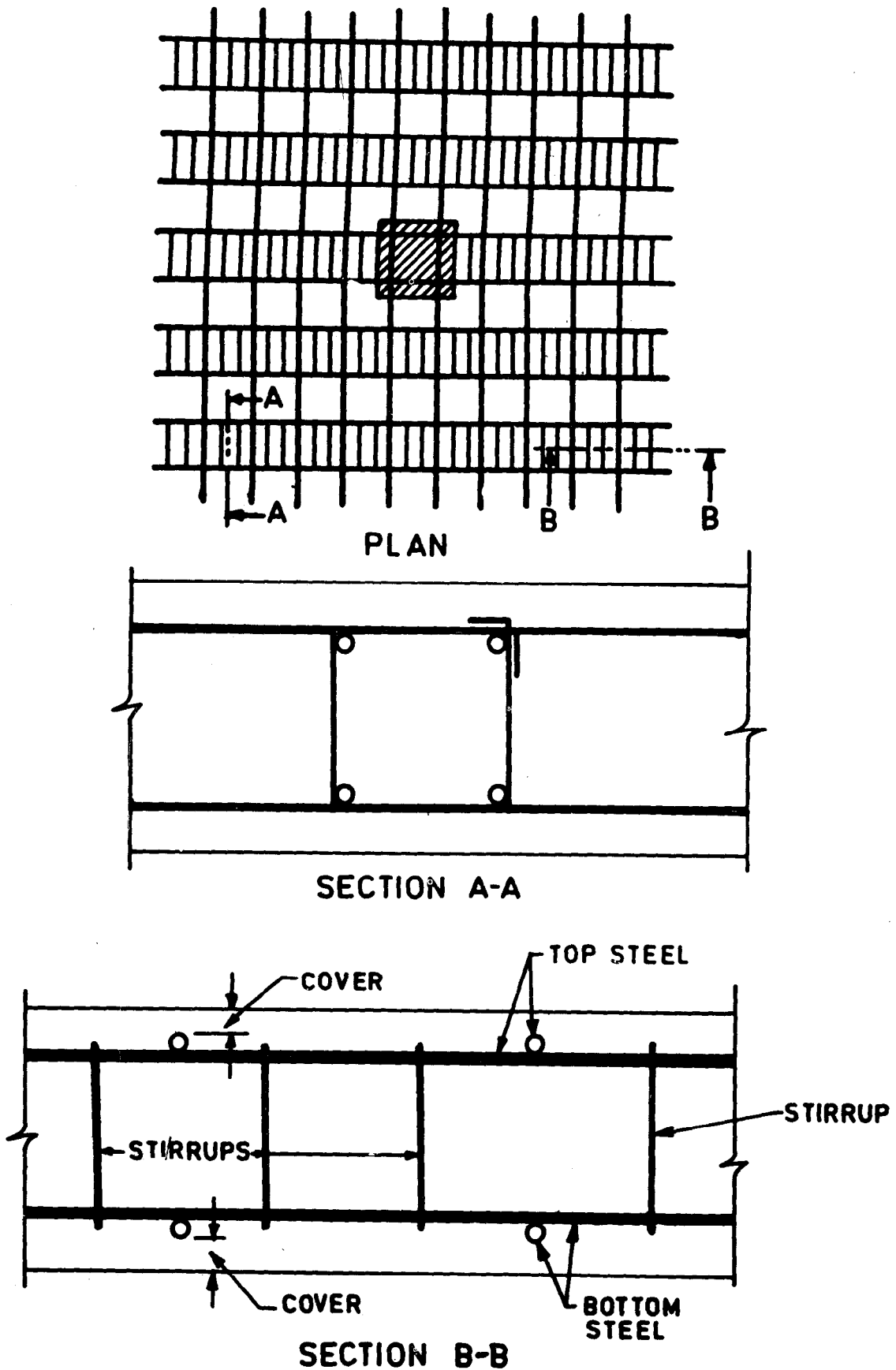

FIG. 9.18 SHEAR REINFORCEMENT FOR SLAB AT COLUMN HEADS

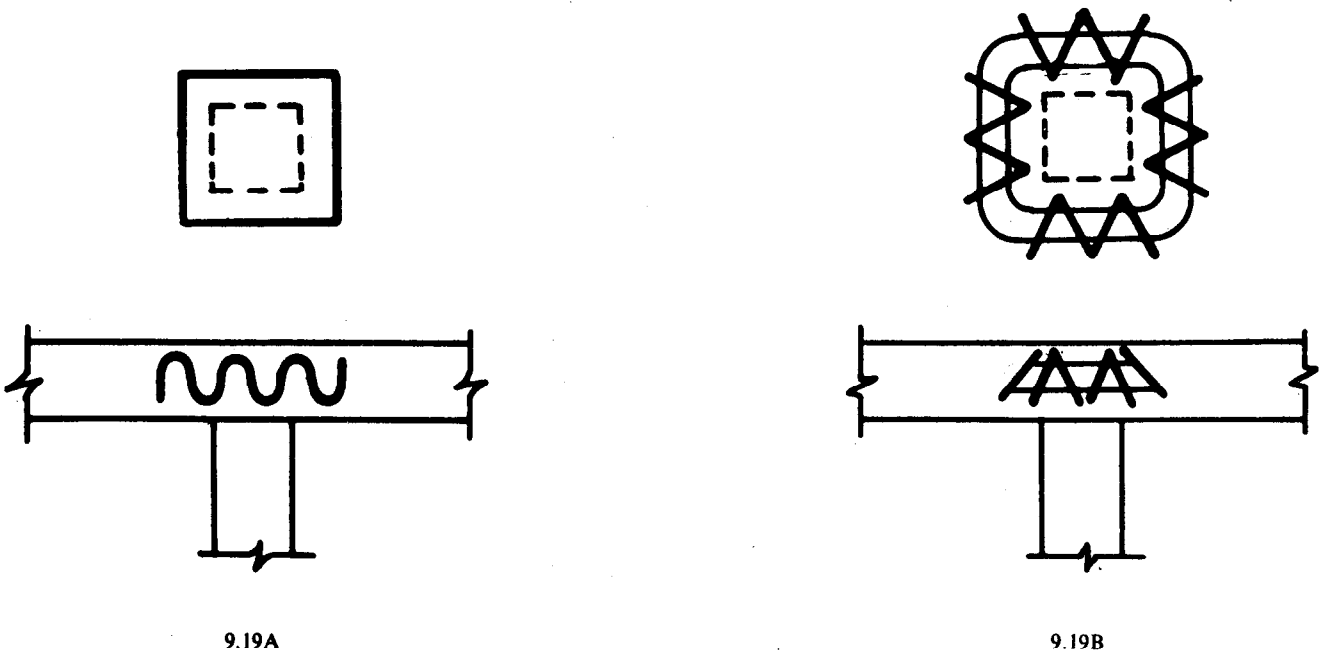

FIG. 9.19 EXAMPLES OF SHEAR REINFORCEMENT FOR SLABS AT COLUMN HEADS

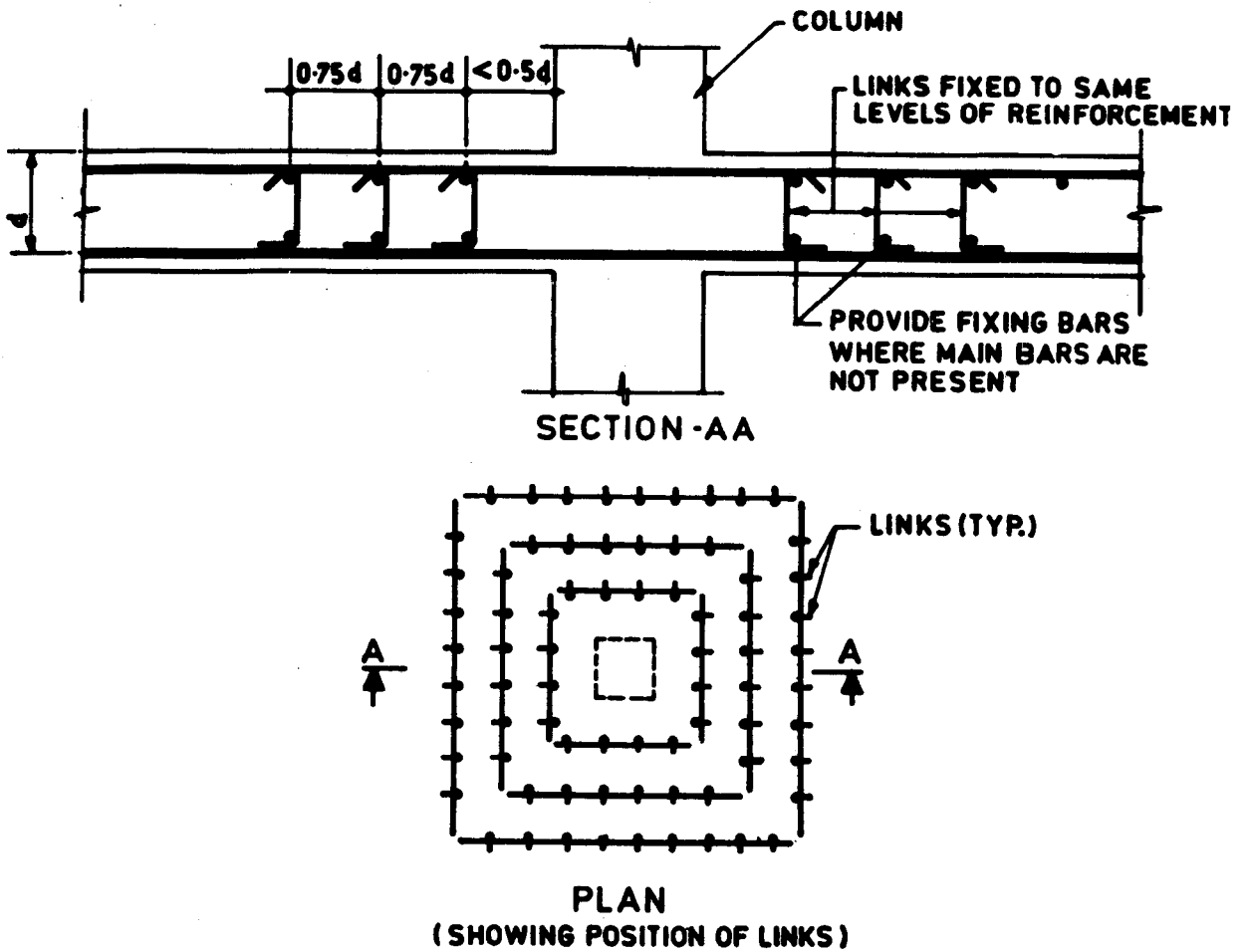

FIG. 9.20 STIRRUPS—VERTICAL LINKS

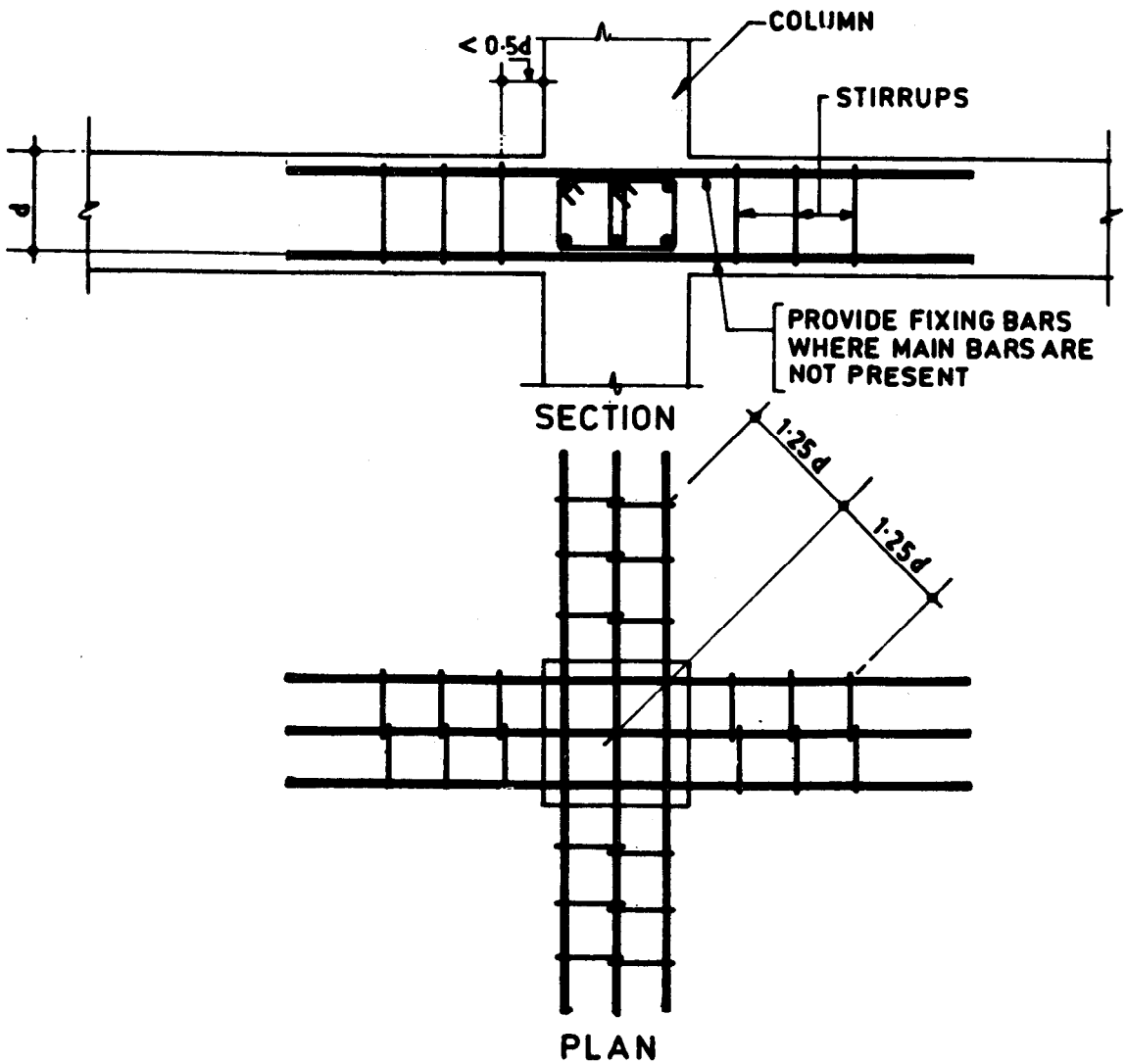

FIG. 9.21 BEAM-CAGE STIRRUPS (SUPPLEMENTED BY ISOLATED STIRRUPS).

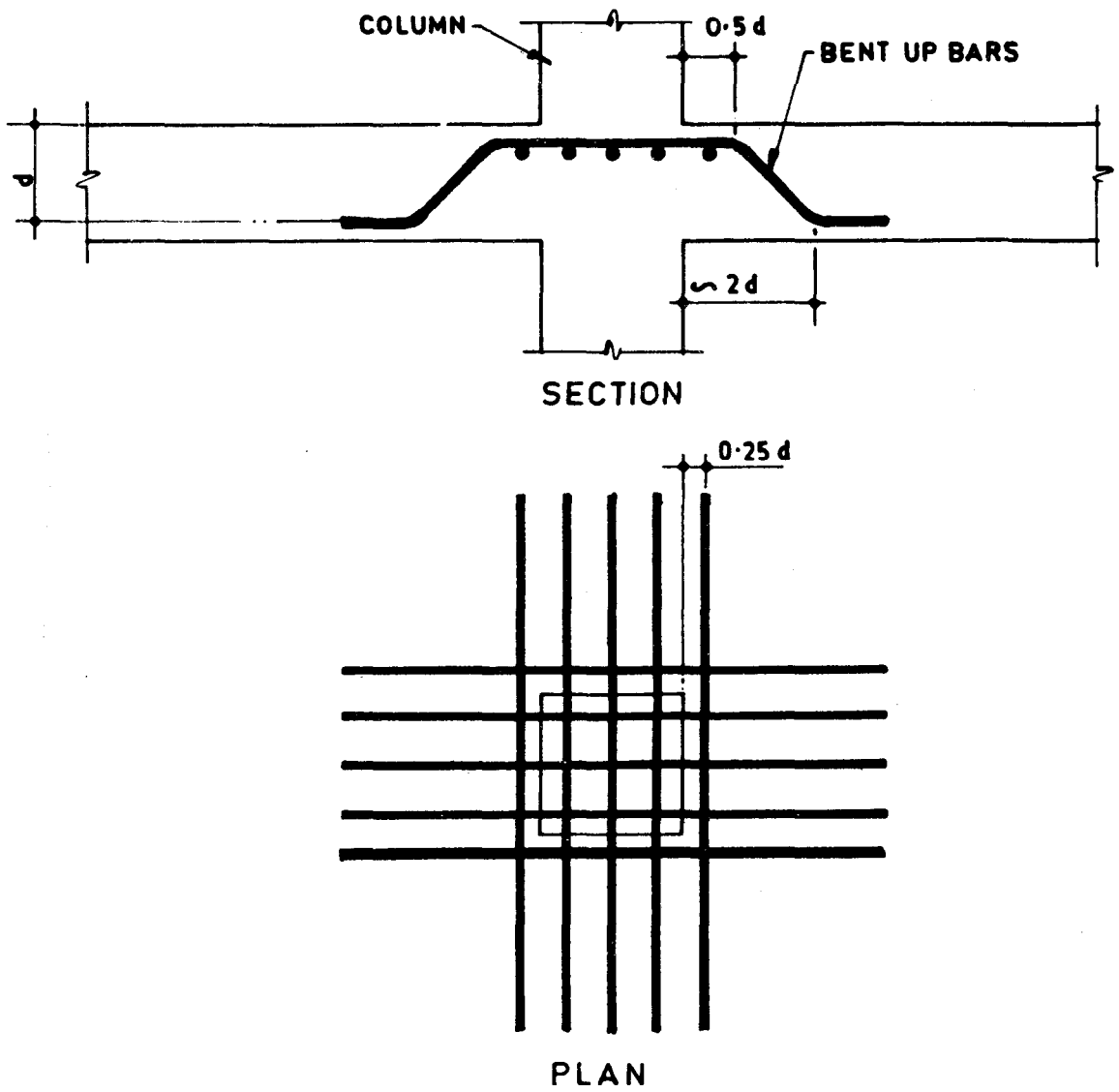

FIG. 9.22 BEAM-CAGE STIRRUPS (SUPPLEMENTED BY BENT-UP BARS).

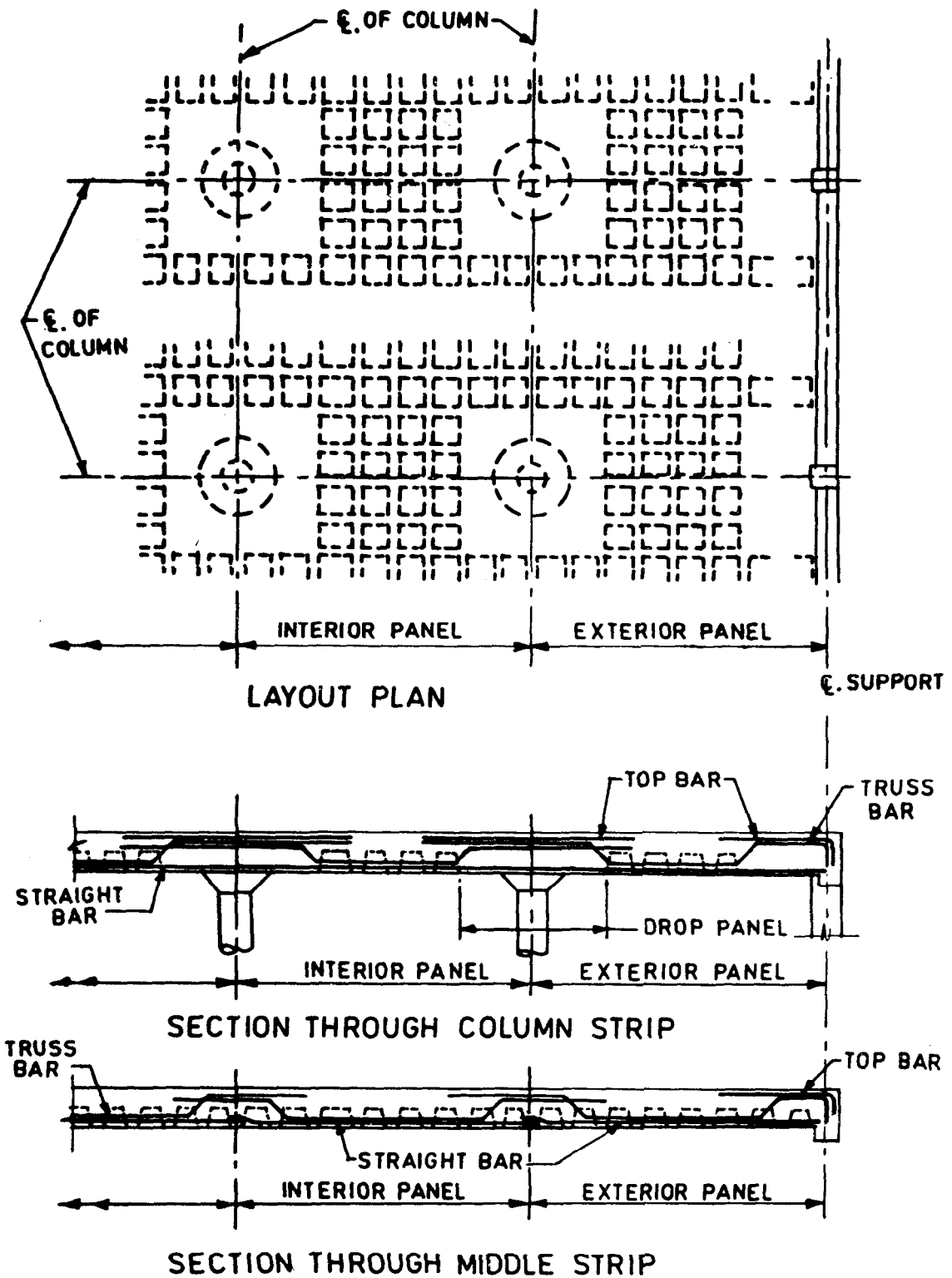

FIG. 9.23 TYPICAL ARRANGEMENT OF BARS IN A WAFFLE SLAB

SECTION 10
Stairs

SECTION 10

STAIRS

10.0 Introduction — Reinforced concrete stairs are self-supporting or carried on beams or walls. They are often built around open or lift wells supported according to the type of structure. Staircase with cantilevering treads from a column or wall support are also commonly used for fire escape stairs, etc.

NOTE — Minimum steel, bar spacing and cover should conform to the requirements specified for slabs and beams as appropriate.

10.1 Flight Supported on Side Beams — The reinforcement detail for a staircase supported by edge beams along each edge is similar to the one supported along its edges by a brick wall. Figure 10.1 shows cross-sectional details of a flight with two types of arrangements.

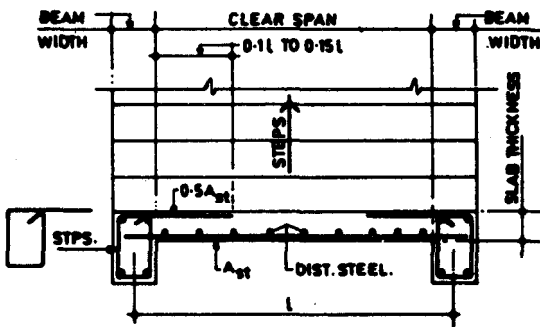

10.1A

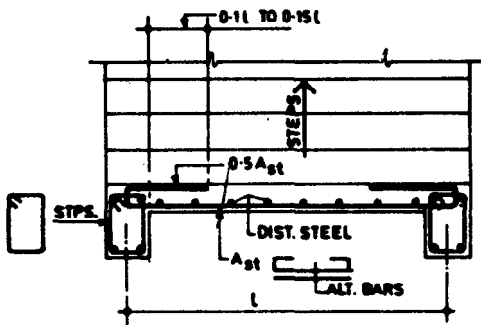

10.1B

FIG. 10.1 TYPICAL CROSS-SECTION OF STAIRCASE SUPPORTED ON SIDE BEAMS

10.2 Flight Supported on Central Beam — Figure 10.2 shows the cross-sectional detail of a typical staircase supported on a central (stringer) beam. Each step of the staircase is acting as a cantilever on both sides of the main beam.

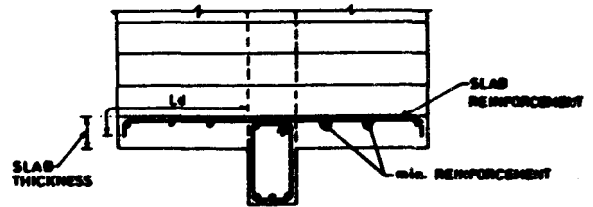

FIG. 10.2 TYPICAL CROSS-SECTION OF A FLIGHT WITH A CENTRAL BEAM

10.3 Flights and Landings Supported at Ends — Figures 10.3 and 10.4 illustrate two types of stairs with flight and landing supported at ends. Figure 10.3 gives reinforcement details of a flight spanning from outer edge to outer edge of landing. Figure 10.4 gives reinforcement details of a flight together with its landings spanning from inner edge to inner edge of landings.

10.3.1 Flight Supported on Brick Wall — Figure 10.5 shows the elevation detail for a straight stair flight with its landings at its ends supported by brick walls.

10.4 Cranked Beams — Straight stairflights and landings supported by side or centre beams as shown in Fig. 10.1 to 10.3 will require cranked beams. The elevation details of cranked beam is shown in Fig. 10.6.

The method of reinforcing a cranked beam is shown in Fig. 10.6. The bars at the intersections shall be carried for development length past the intersection, and one set of bars shall be cranked inside the other because of fouling. To complete the intersection extra bars, normal to the angle of intersection, are usually added as shown by the bars *c* and *f*.

10.5 Cantilever Stairs — A typical details of a tread cantilevering from a wall is given in Fig. 10.7. A typical detail of a staircase cantilevering from the side of a wall is shown in Fig. 10.8.

10.6 Slabless Tread Riser Stairs — A typical detail of a slabless tread riser staircase is given in Fig. 10.9.

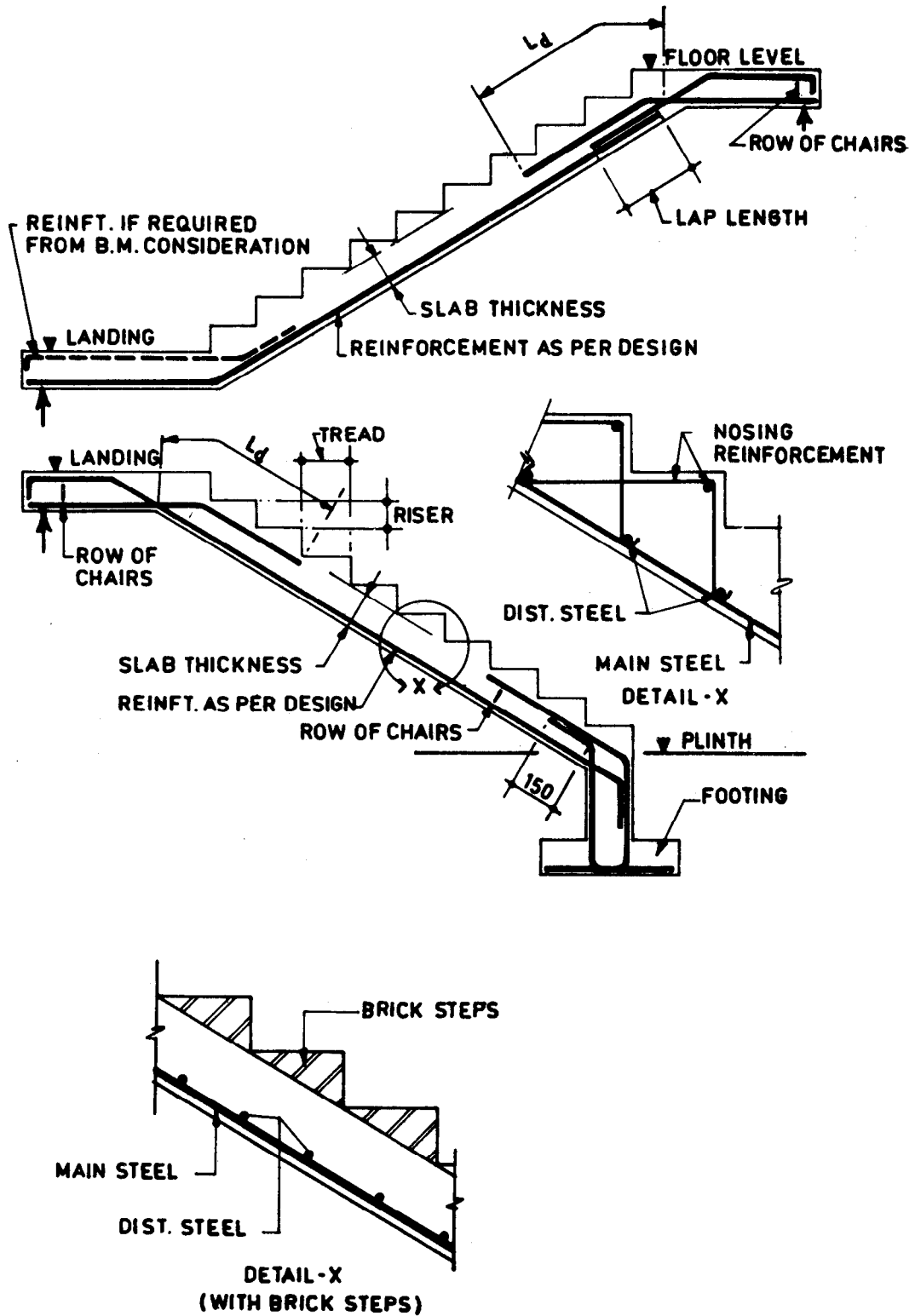

FIG. 10.3 STAIRS SUPPORTED AT ENDS OF LANDINGS—SHOWING POSITION OF MAIN REINFORCEMENT

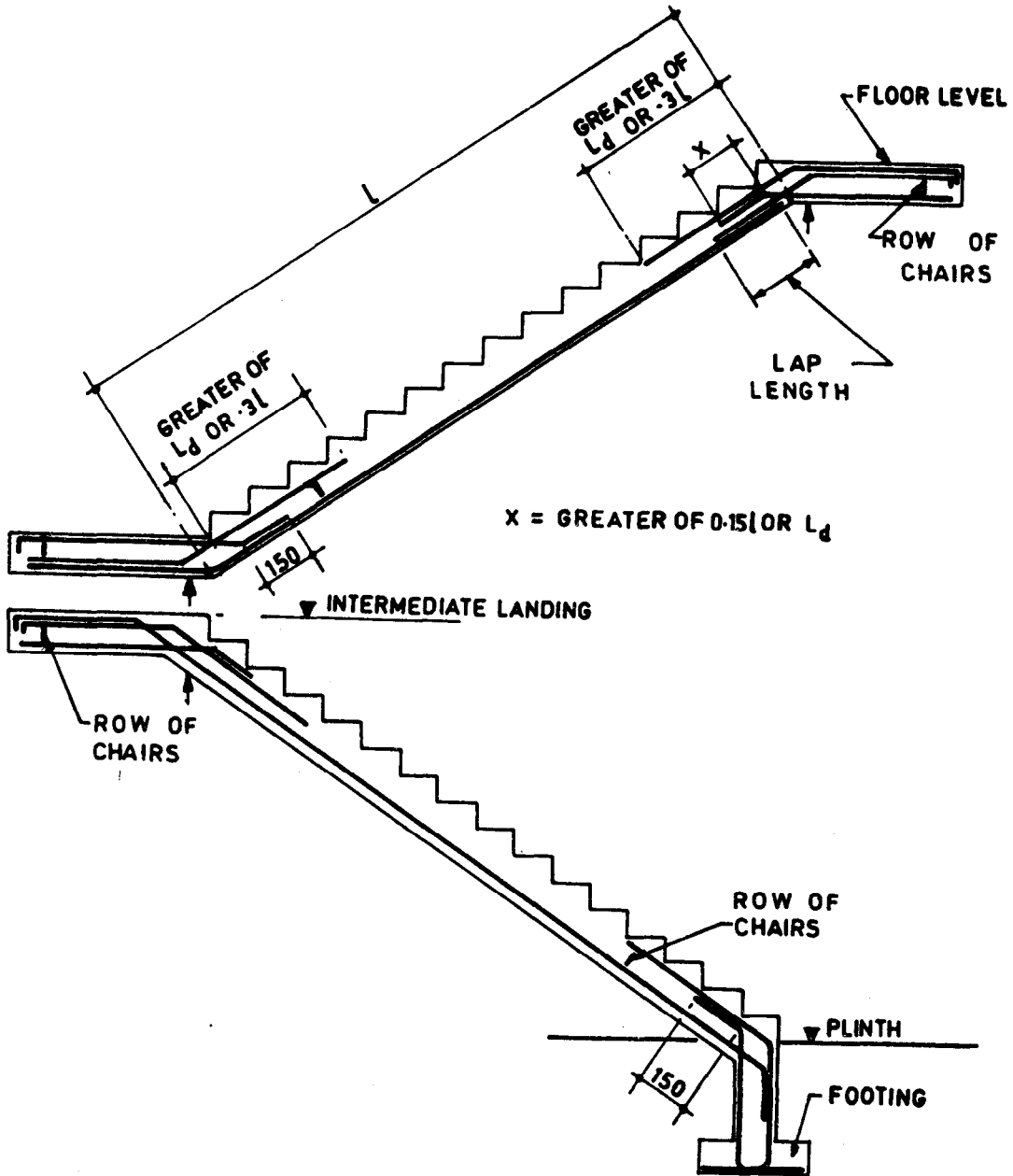

FIG. 10.4 STAIRS SUPPORTED AT ENDS OF FLIGHTS—SHOWING MAIN REINFORCEMENT

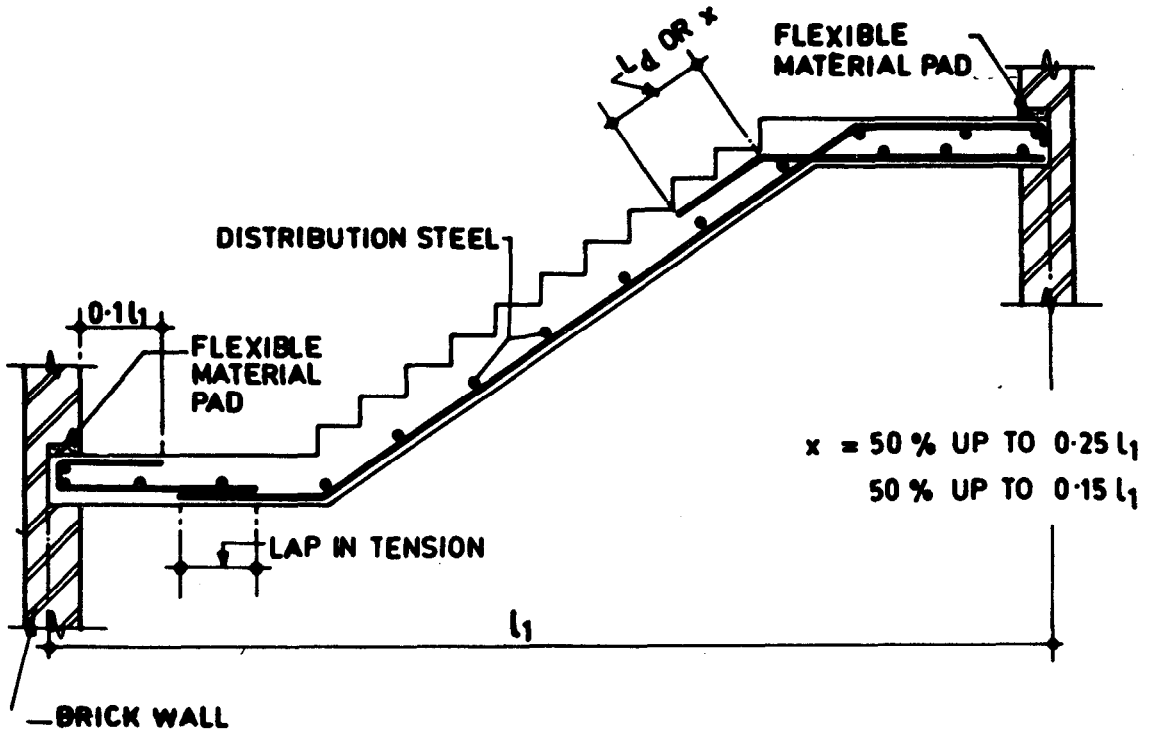

FIG. 10.5 CROSS-SECTIONAL DETAILS OF A SINGLE SPAN STRAIGHT FLIGHT SUPPORTED ON BRICK WALLS

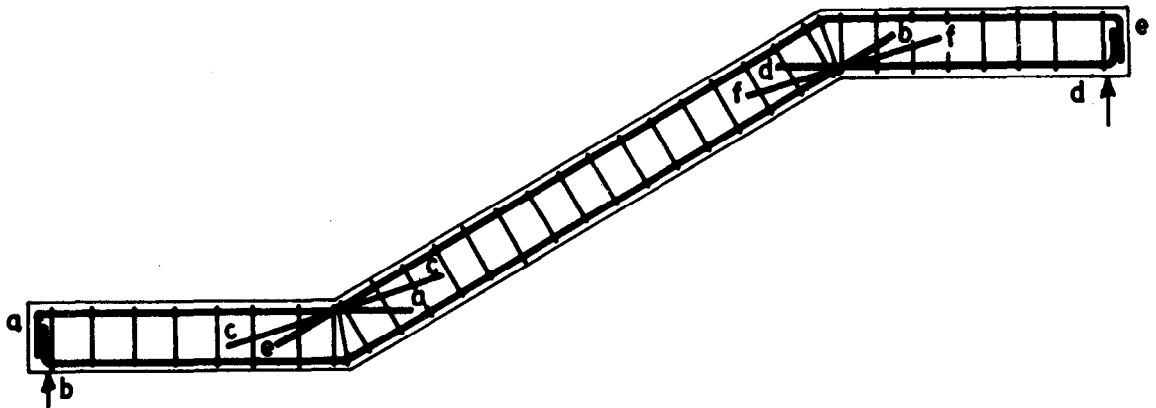
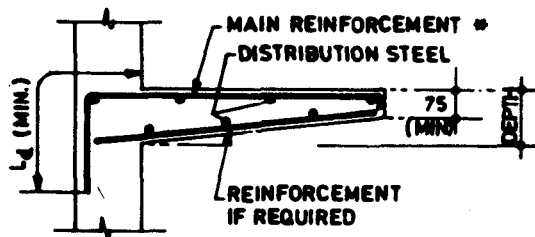

FIG. 10.6 CRANKED BEAM



* 50 % OF MAIN REINFORCEMENT CAN BE CURTAILED AT A DISTANCE OF $0.5 l$ OR L_d FROM THE FACE OF SUPPORT

FIG. 10.7 STEPS CANTILEVERING FROM A CONCRETE WALL

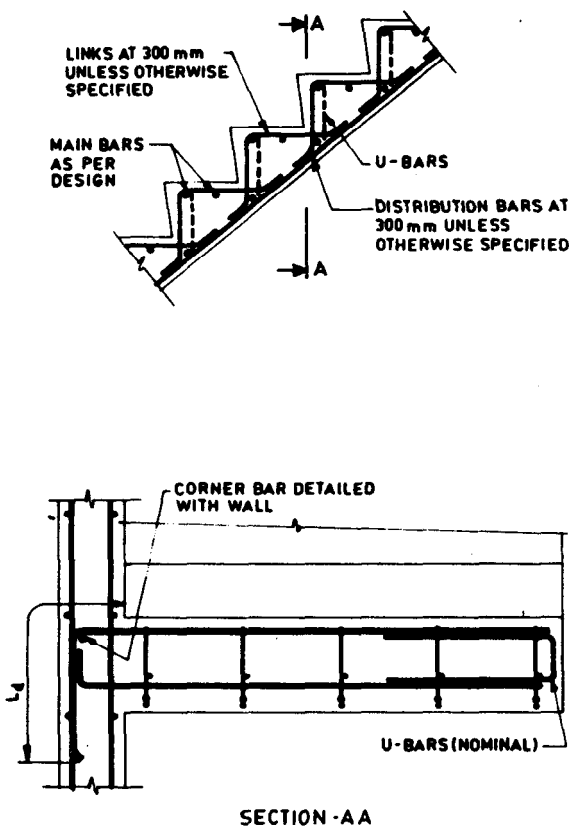

FIG. 10.8 TYPICAL DETAILS OF A STAIR CASE CANTILEVERING FROM THE SIDE OF A WALL

10.7 Staircases are normally detailed diagrammatically in plan or section. This is best done by arranging the placing detail and bending schedule adjacent to one another on a single drawing sheet (see Fig. 10.10).

10.8 Re-entrant Corners — When tension bars meeting at a corner produce a resultant force resisted by the concrete cover, the bars shall be crossed over and anchored on either side of the cross-over by adequate anchorage length for taking up the stresses in the bar (see Fig. 10.11).

10.9 Hand Rail Supports — The designer should ensure that adequate consideration is given to the reinforcement detailing for hand rail supports. If pockets are left in the concrete into which the hand rail posts are later concreted, the reinforcement shall pass around the pockets and be anchored into the main body of the concrete. If inserts are set into the concrete these should have steel bars passing around them to have sufficient anchorage ties build-in.

10.10 Where construction requires bars larger than # 10 or ϕ 16 should not be detailed to be rebend, but mild steel bars are recommended if rebending is unavailable.

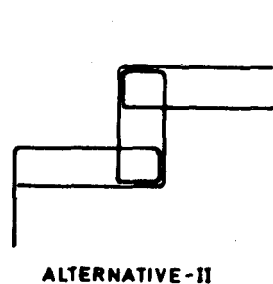
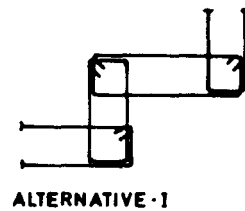
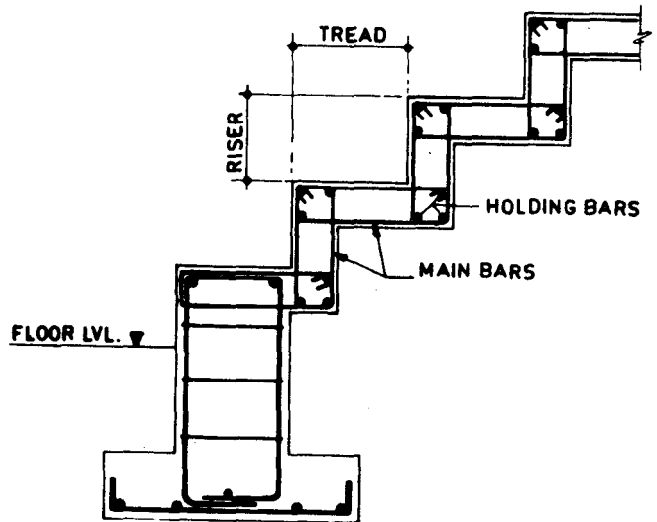

FIG. 10.9 TYPICAL DETAILS OF A SLABLESS TREAD RISER STAIRCASE

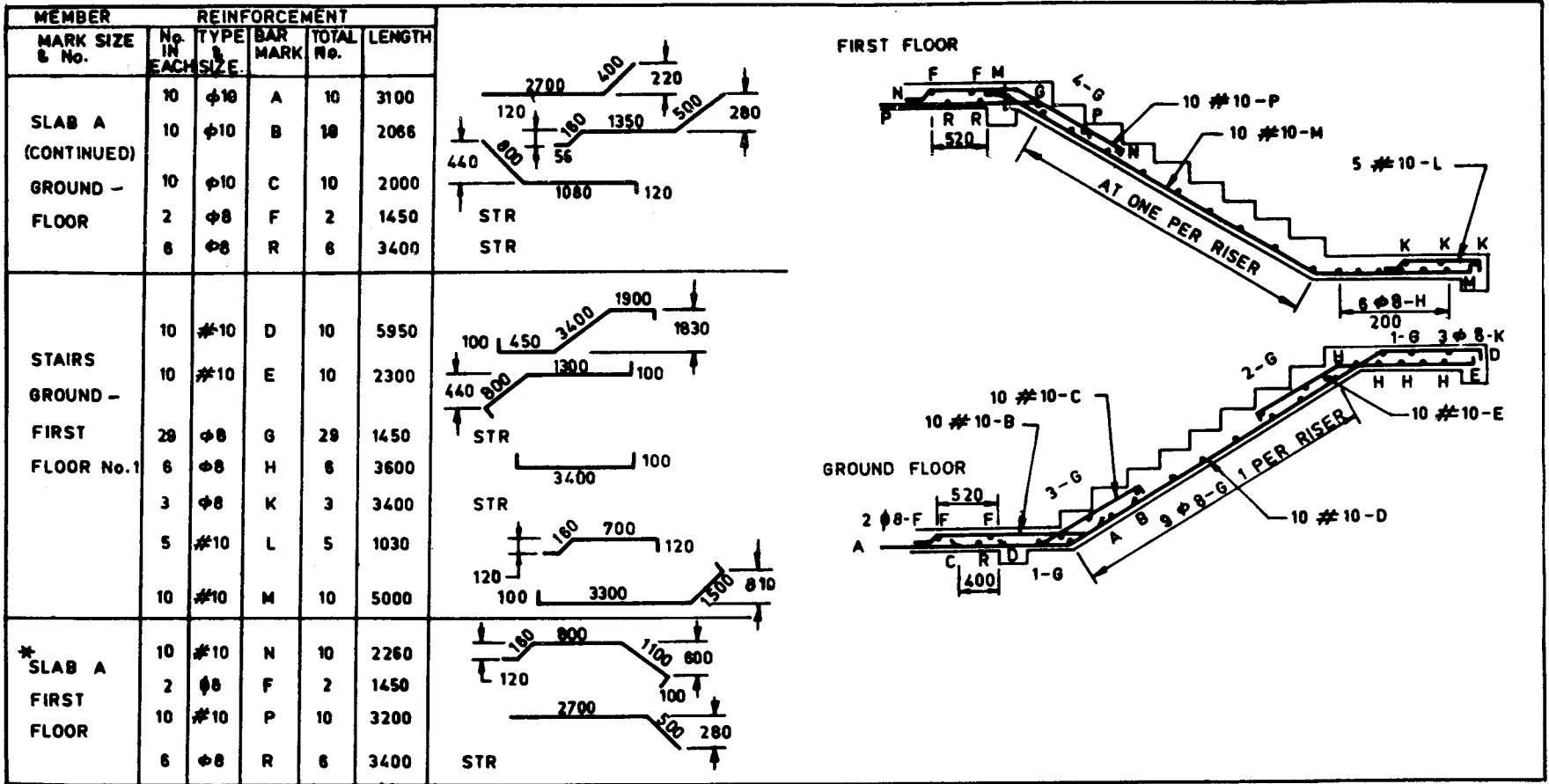

Fig. 10.10 AN EXAMPLE OF A STAIR WITH PLACING DETAIL AND BENDING SCHEDULE

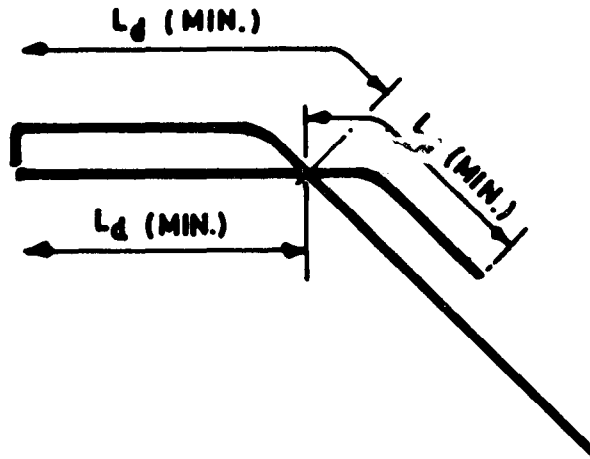

FIG. 10.11. REQUIREMENTS FOR TENSION BARS CROSSING EACH OTHER AT A POINT

SECTION 11

Special Structures—Deep Beams, Walls, Shells and Folded Plates,
Water Tanks, RC Hinges, Concrete Pipes, Machine Foundations, and
Shear Walls

SECTION 11

SPECIAL STRUCTURES — DEEP BEAMS, WALLS, SHELLS AND FOLDED PLATES WATER TANKS, RC HINGES, CONCRETE PIPES, MACHINE FOUNDATIONS, AND SHEAR WALLS

11.1 Deep Beams — A beam shall be deemed to be a deep beam when the ratio of effective span to overall depth (l/D) is less than:

- a) 2.0 for simply supported beam, and
- b) 2.5 for a continuous beam.

11.1.1 Reinforcement

11.1.1.1 Positive reinforcement — The tensile reinforcement required to resist positive bending moment in any span of a deep beam shall:

- a) extend without curtailment between supports;
- b) be embedded beyond the face of each support so that, at the face of the support, it shall have a development length not less than $0.8 L_d$; where L_d is the development length for the design stress in the reinforcement (Fig. 11.1);

- c) be placed within a zone of depth equal to $(0.25 D - 0.05 l)$ adjacent to the tension face of the beam where D is the overall depth and l is the effective span. The arrangement is illustrated in Fig. 11.1.

NOTE 1 — Anchorage of positive reinforcement may be achieved by bending of the bars in a horizontal plane (see Fig. 11.1B).

NOTE 2 — The main reinforcement may be supplemented by two layers of mesh reinforcement provided near each of the two faces; in which case the spacing between two adjacent parallel bars must not exceed twice the thickness of deep beam or 300 mm, whichever is greater.

11.1.1.2 Negative reinforcement

- a) **Termination of reinforcement** — For tensile reinforcement required to resist negative bending moment over a support of a deep beam:

- 1) it shall be permissible to terminate not more than half of the reinforcement at a

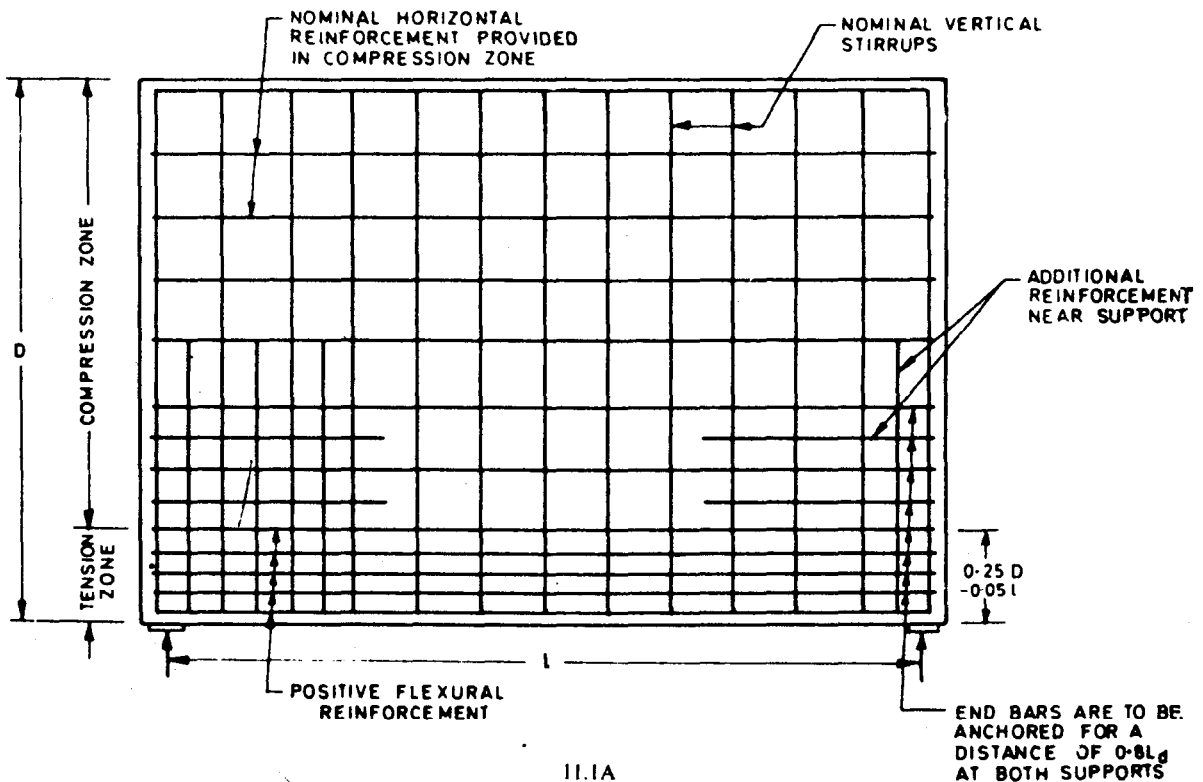

FIG. 11.1 REINFORCEMENT DETAILING IN SIMPLY SUPPORTED DEEP BEAMS (Continued)

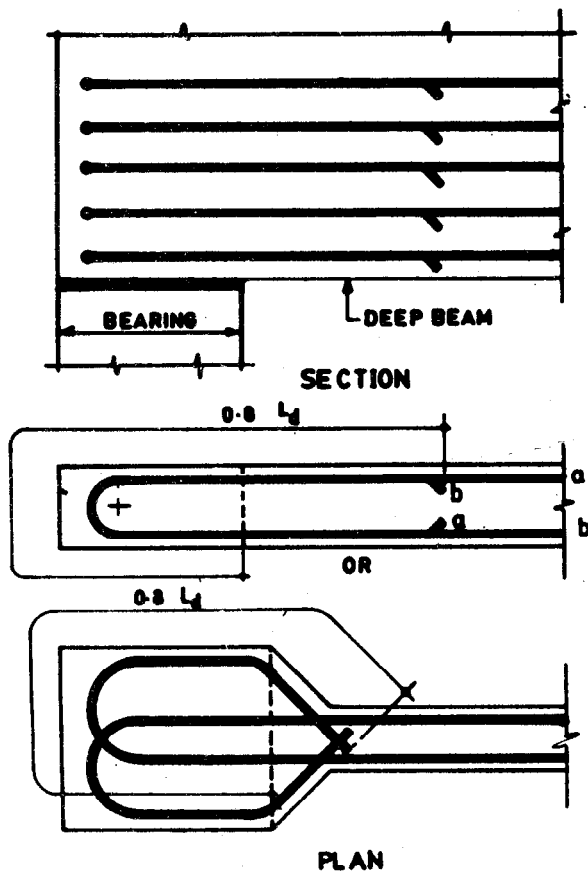

FIG. 11.1B

FIG. 11.1 REINFORCEMENT DETAILING IN SIMPLY SUPPORTED DEEP BEAMS

distance of $0.5 D$ from the face of the support; and

- 2) the remainder shall extend over the full span.
- b) *Distribution steel*—When ratio of clear span to overall depth is in the range 1.0 to 2.5, tensile reinforcement over a support of a deep beam shall be placed in two zones comprising:

- 1) a zone of depth $0.2 D$, adjacent to the tension face, which shall contain a proportion of the tension steel given by

$$0.5 \left(\frac{l}{D} - 0.5 \right)$$

where

l = clear span, and

D = overall depth.

- 2) a zone measuring $0.3 D$ on either side of the mid-depth of the beam, which shall contain the remainder of the tension steel, evenly distributed.

For span to depth ratios less than unity, the steel shall be evenly distributed over a depth of $0.8 D$ measured from the tension face. Figure 11.2 shows the disposition of this reinforcement.

11.1.1.3 Vertical reinforcement—If forces are applied to a deep beam in such a way that hanging action is required, bars or suspension stirrups shall be provided to carry all the forces concerned (see Fig. 11.3A).

11.1.1.4 Side face reinforcement—Side face reinforcement shall comply with requirements of minimum reinforcement for walls.

11.1.1.5 Stirrups for deep beams—To stiffen the legs of stirrups for deep beams against buckling during construction, tie clips to the legs and horizontal bars. Space the clips horizontally at every second or third stirrup, subject to a maximum space of 600 mm, and vertically at alternate intersections of horizontal bars (see Fig. 11.3B).

11.2 Walls—This clause deals with reinforced concrete walls other than retaining walls.

NOTE—A wall is a vertical structural element whose length exceeds four times its thickness. A wall containing only minimum reinforcement which is not considered in design forms a plain concrete wall.

11.2.1 Walls to Carry Vertical Loads—Where reinforced concrete walls are intended to carry vertical loads, they should be designed generally in accordance with the recommendations given for columns. The provisions with regard to transverse reinforcement to restrain the vertical bars against buckling need not be applied to walls in which the vertical bars are not assumed to assist in resisting compression. The minimum reinforcement shall be as specified in 11.2.1.1. The minimum thickness of wall should not be less than 100 mm.

11.2.1.1 Reinforcement—The minimum reinforcement for walls shall be provided as given below:

- a) The minimum ratio of vertical reinforcement to gross concrete area shall be 0.004 (irrespective of type and grade of steel).
- b) Vertical reinforcement shall be spaced not farther apart than three times the wall thickness or 450 mm, whichever is less.
- c) The minimum ratio of horizontal reinforcement to gross concrete area shall be:
 - 1) 0.0020 for deformed bars not larger than 16 mm in diameter and with a characteristic strength of 415 N/mm² or greater.
 - 2) 0.0025 for other types of bars.

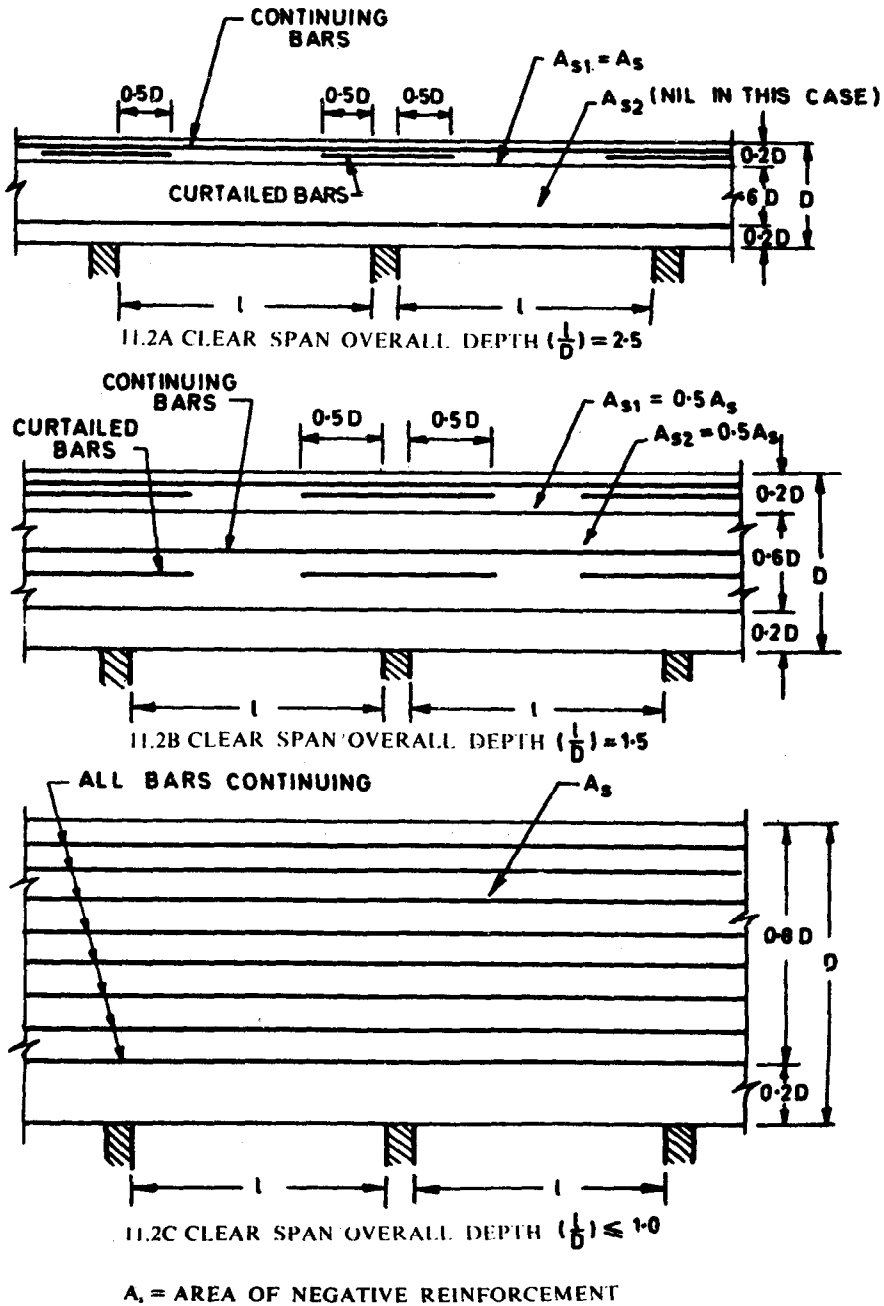

FIG. 11.2 DISPOSITION OF NEGATIVE REINFORCEMENT IN CONTINUOUS DEEP BEAMS

- 3) 0.0020 for welded wire fabric not larger than 16 mm in diameter.
- d) Horizontal reinforcement shall be spaced not farther apart than three times the wall thickness or 450 mm.
- e) In case of plain concrete walls (where vertical load is not predominant) quantity of vertical reinforcement given in (a) shall be modified as follows:

- 1) 0.0012 for deformed bars not larger than 16 mm in diameter and with a characteristic strength of 415 N/mm² or greater.
- 2) 0.0015 for other types of bars.
- 3) 0.0012 for welded wire fabric not larger than 16 mm in diameter.

11.2.2 Walls to Resist Moment and Shear — Horizontal wall reinforcement may be required

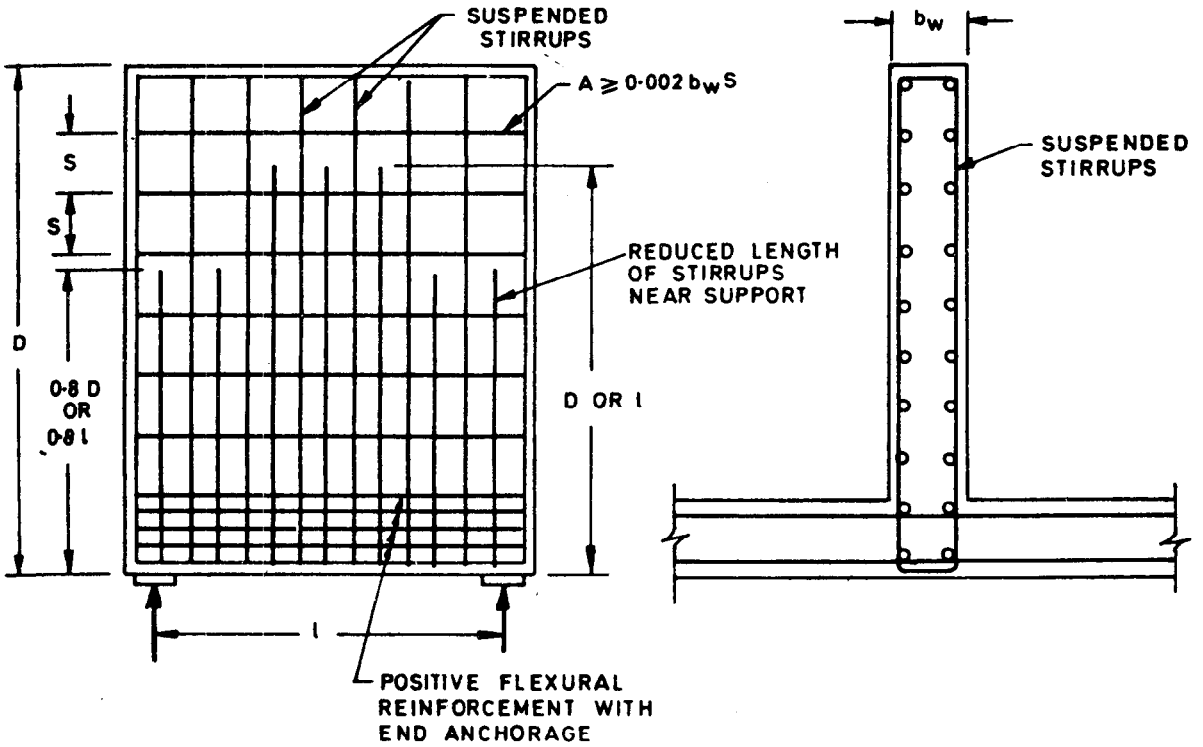

Fig. 11.3A

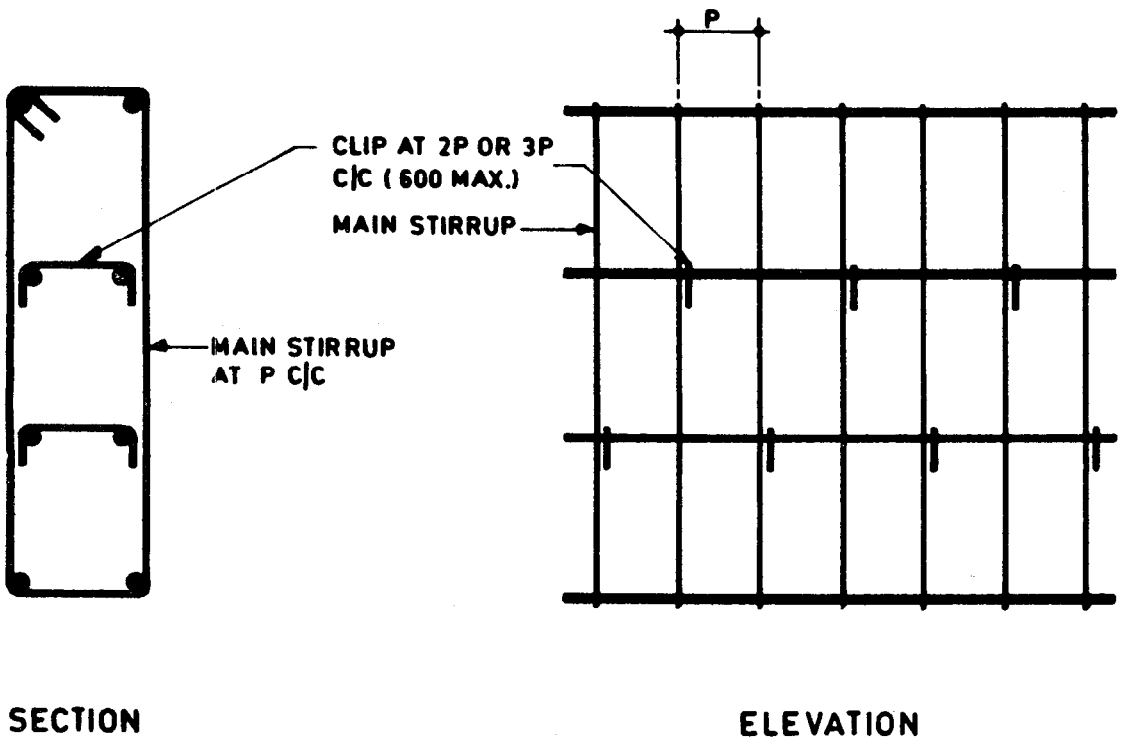

Fig. 11.3B

FIG. 11.3 SUSPENDED BARS FOR DEEP BEAMS

by the designer to resist moment, shear or merely changes in length due to temperature or shrinkage. In any case, unless the designer indicates a shrinkage control joint at this point, all the horizontal bars in one or sometimes both faces of a wall should be sufficiently extended past a corner or intersection for development length (see Fig. 11.4). Nevertheless it is necessary for the designer to indicate which, if any, horizontal reinforcement should be extended for full development at intersections and corners of walls and footings. Typical details are shown in Fig. 11.4 for resistance against moment inward, outward, or both with the reinforcement from the appropriate face or faces anchored. Figure 11.5 shows a cross-section through floors and walls indicating general arrangement of reinforcement.

11.2.3 Thin Walls—In case of thin walls, reinforcement has to be detailed in such a way that the concrete can be thoroughly compacted.

For walls of thickness 170 mm or less, where the insertion of a vibrator may lead to difficulties, a single layer of vertical and horizontal bars may be provided at the centre of the wall and an external vibrator may be used (see Fig. 11.6A).

11.2.4 Thick Walls—In case of walls of thickness greater than 170 mm but less than or equal to 220 mm, and also for walls of thickness greater than 220 mm with more than nominal reinforcement, provide two layers of reinforcement in both vertical and horizontal directions, the former being placed on the inside of the latter (see Fig. 11.6B). Clips should be provided to restrain the vertical bars against buckling or displacement during concreting. In walls of thickness greater than 220 mm with nominal reinforcement, horizontal steel may be placed inside the vertical steel to reduce the possibility of the coarse aggregate being 'hung-up' on the horizontal bars (see Fig. 11.6C).

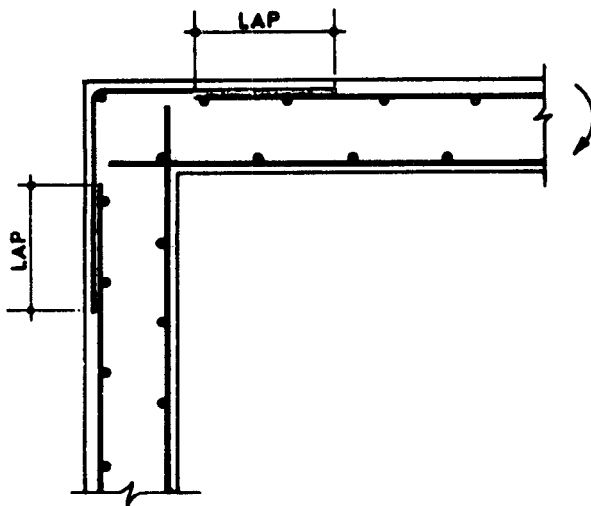

11.4A

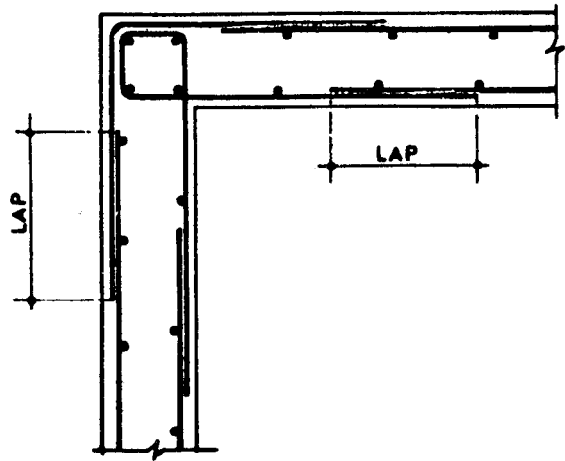

11.4B

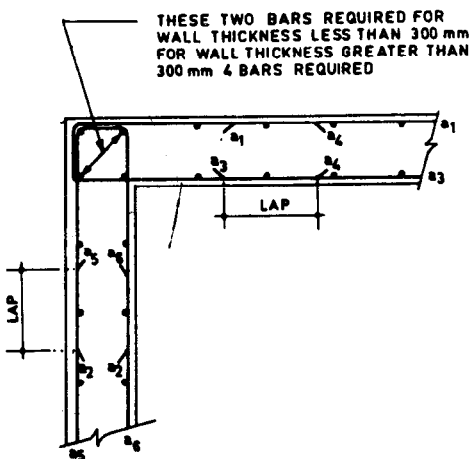

11.4C

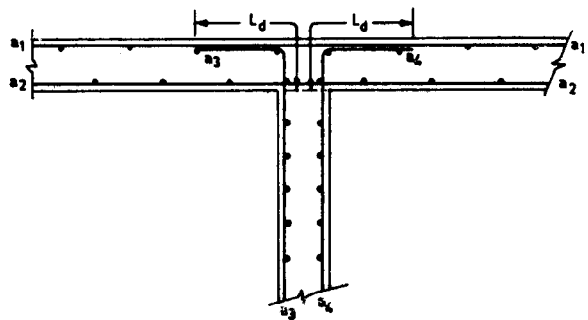

11.4D

FIG. 11.4 TYPICAL CORNER AND INTERSECTION DETAILS FOR REINFORCED CONCRETE WALLS

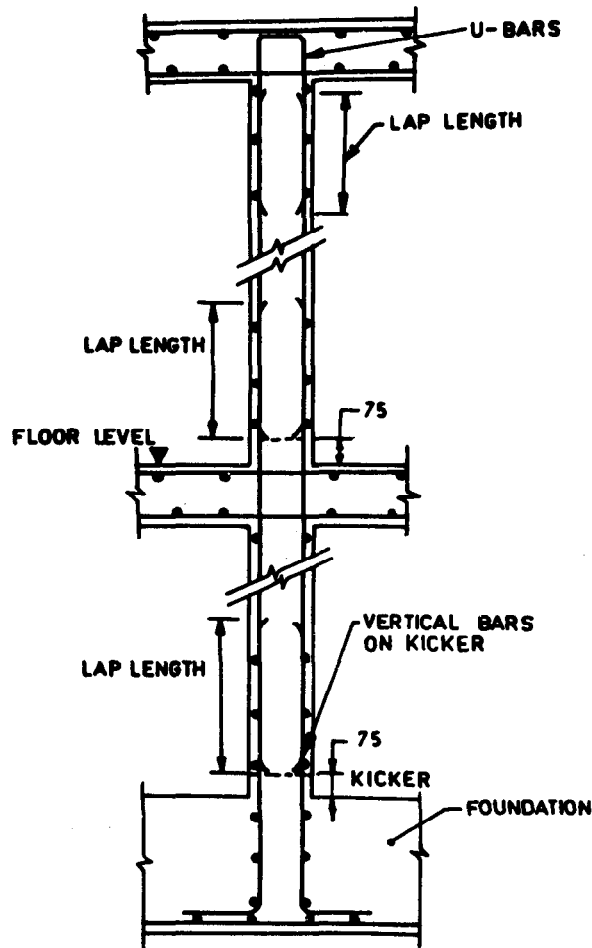

NOTE—Horizontal bars are placed outside vertical bars

FIG. 11.5 GENERAL CROSS-SECTIONAL DETAILS OF WALLS

11.2.4.1 Walls with vertical reinforcement close to or more than 0.4 percent of the plan area of concrete—In heavily reinforced walls (with vertical reinforcement close to 0.4 percent of the plan area of concrete), the following requirements should be satisfied:

- a) Ensure that clips are provided for vertical bars at a horizontal spacing not exceeding twice the wall thickness.
- b) Vertical bars that are not fully restrained are placed within a centre-to-centre distance of 200 mm from a bar that is fully restrained.
- c) Vertical spacing of clips should not exceed 15 times the diameter of the vertical reinforcement or 300 mm whichever is the lesser.
- d) At all splices, the top of each lower bar and the bottom of each upper bar are restrained by means of clips.

- e) Preferably clips (alternately reversed) may be used, or alternately, truss-type clips as indicated in Fig. 11.7 may also be used.

11.2.5 Splices at Top of Wall—Whenever a slab is to be cast at the top of a wall, detail the vertical continuity of steel from the walls into the top of the slab as follows:

- a) If the diameter of deformed bars is less than or equal to 10 mm, the straight bars can be bent into the slab as shown in Fig. 11.8A.
- b) If the diameter of deformed bars is greater than 10 mm, the details shall be as shown in Fig. 11.8B or 11.8C.
- c) If mild steel bars (any diameter) are used, they can be safely bent into the slab without any damage.

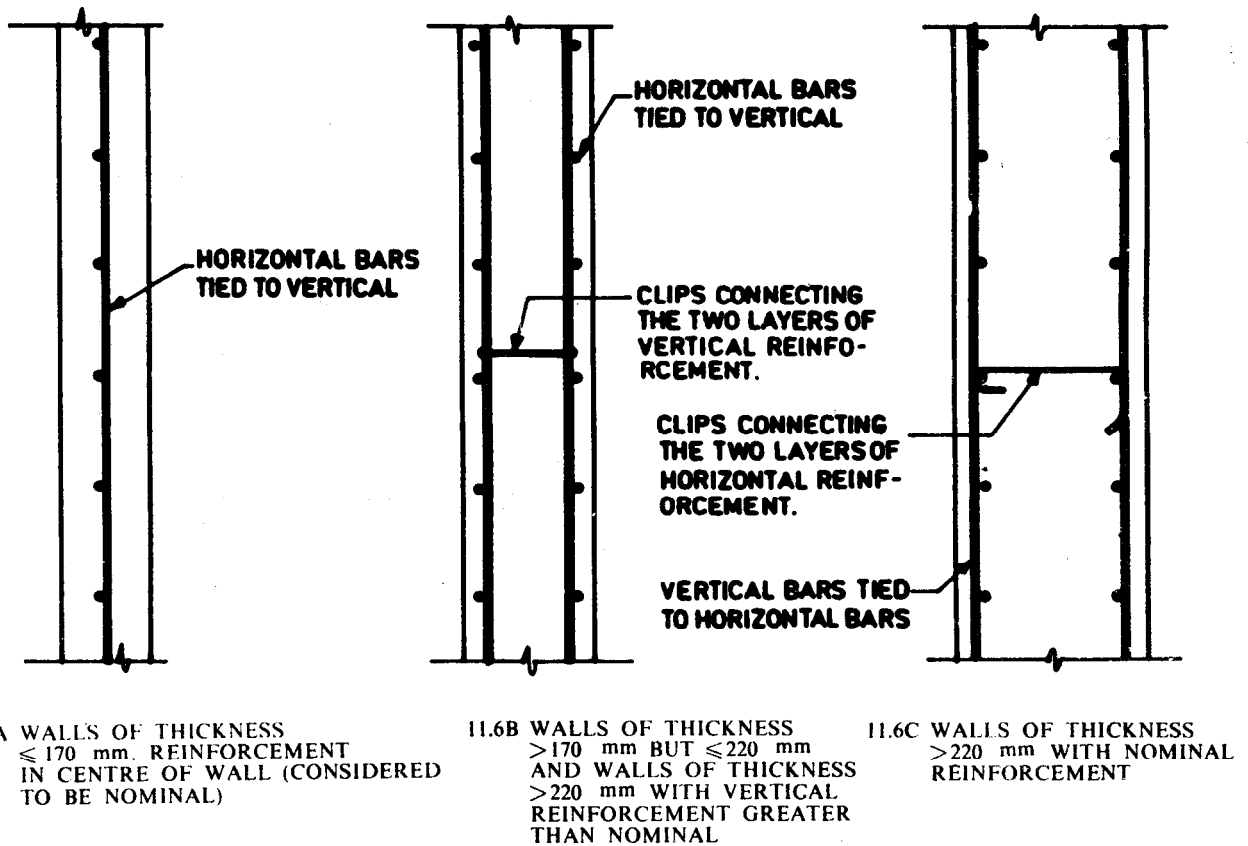

NOTE — POSITION OF CLIPS TO BE INDICATED ON THE DRAWING

FIG. 11.6 VERTICAL SECTIONS FOR WALLS

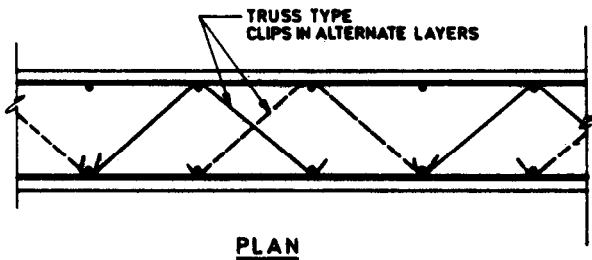

FIG. 11.7 TRUSS-TYPE CLIPS IN ALTERNATE LAYERS IN A WALL

11.2.6 Walls Constructed by Means of Sliding or Climbing Shuttering — Detailing of walls to be constructed by sliding or climbing shuttering is affected by construction techniques that are often unique to the system involved. These techniques include, for example, the use of jacking rods and spacers, are reliant on casting cycles, have separation problems, and depend upon a variety of factors that require special detailing, and should thus be planned in conjunction with the

contractor. In general, connections to slabs and beams are by means of chases or pockets (or both) as it is not generally feasible to leave splice bars protruding from the walls. Splice bars to be bent out should normally be not larger than # 10 or $\phi 16$. If heavier splices are required and it is not possible to provide pockets of adequate size, consider the use of mechanical splices or welding.

When sliding shuttering is used for walls, vertical splices should preferably be staggered to ease placing problems and to prevent the displacement of reinforcement during sliding. Placing details should call attention to adequate wiring together of upper and lower reinforcement.

11.3 Retaining Walls — The shape of a retaining wall is a function of various factors including the natural and final ground profiles, the proximity of and relationship to existing and proposed buildings and services, the economics of cut and fill, the properties of the filling material, external and subsurface drainage, and vertical and surcharge loads. As a result there are different types of retaining walls, for example, cantilever walls with *L*, *T*, and reversed *L* bases,

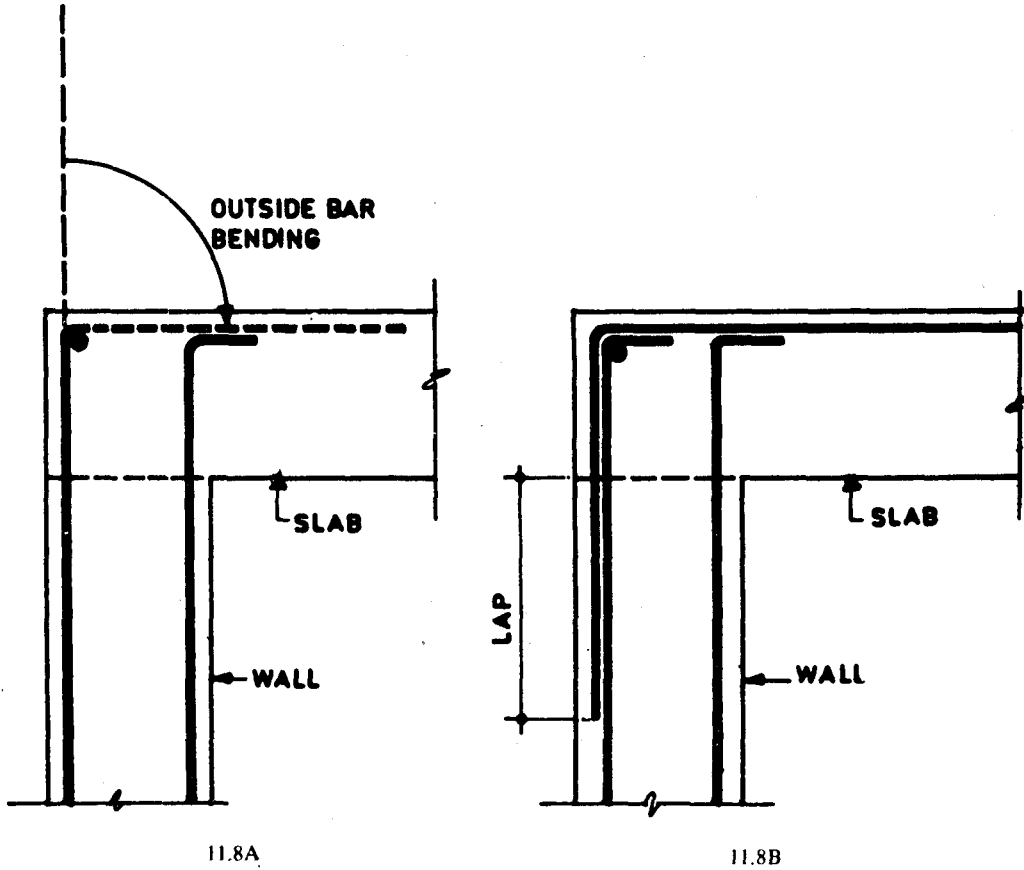

11.8A

11.8B

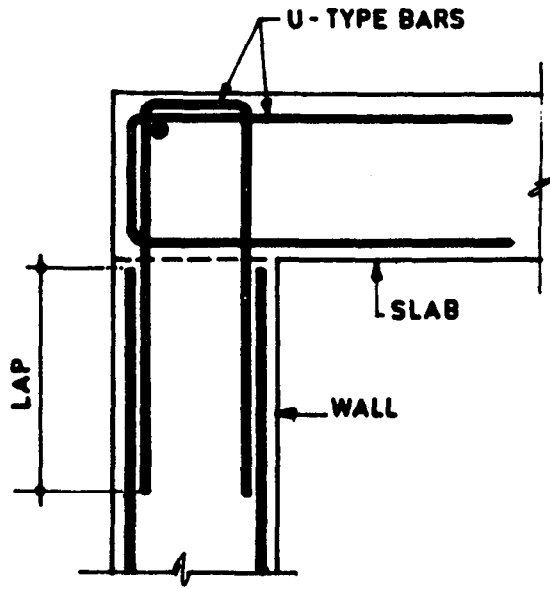

11.8C

FIG. 11.8 SPLICES AT TOP OF WALL

counterforted walls, crib walls, propped and semipropped walls; each type of retaining wall requiring its own individual reinforcing technique (see Fig. 11.9 to 11.12). However, the same general principles apply to all, the more important of which are as follows:

- a) So detail the reinforcement as to keep the placing as simple as possible and to minimize difficulties on site which are often compounded by the conditions under which the work is carried out.
- b) So arrange the distribution of reinforcement (which is governed by design) as to allow for adequate continuity and to avoid abrupt termination of steel by the staggering of laps.
- c) Carefully control the cover to steel on faces adjacent to earth. This applies especially to faces where concrete is to be cast against excavation, for example in footings where the use of levelling course is recommended.
- d) So detail expansion joints in the wall as to ensure that relative movements of continuous sections are minimized by the transfer of shear across joints.
- e) Ensure that at joints steel detailing caters for the incorporation of water-bars when required.
- f) Note that extra reinforcement may be required to meet additional stresses induced by heavy earth compaction and by shrinkage in the wall against the restraint of such compacted earth especially between counterforts.
- g) Provide minimum horizontal reinforcement as per 11.2.1.1 (c) and minimum vertical reinforcement as per 11.2.1.1 (e). The steel (indicated by a dotted line in Fig. 11.9 to 11.11) facilitates the maintenance in position of main bars during concreting.
- h) Take account of the reduction of effectiveness of reinforcing at corners, especially at re-entrant or opening corners. The inclusion of fillets and splay bars in the case of reversed L bases is recommended.
- i) In the case of cantilever walls, place the vertical steel on the outer layer to take maximum advantage of the available lever arm. Horizontal bars may be placed on outside for exposed faces.
- j) Ensure that provision is made for the structure above or beyond the wall where the required information relating to the continuity of the reinforcing must be provided.

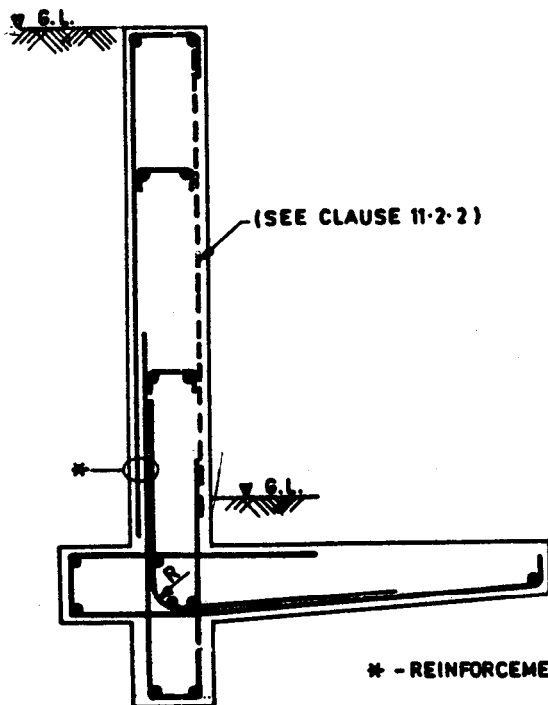

FIG. 11.9 L-WALLS (DISTRIBUTION BARS OMITTED FOR CLARITY)

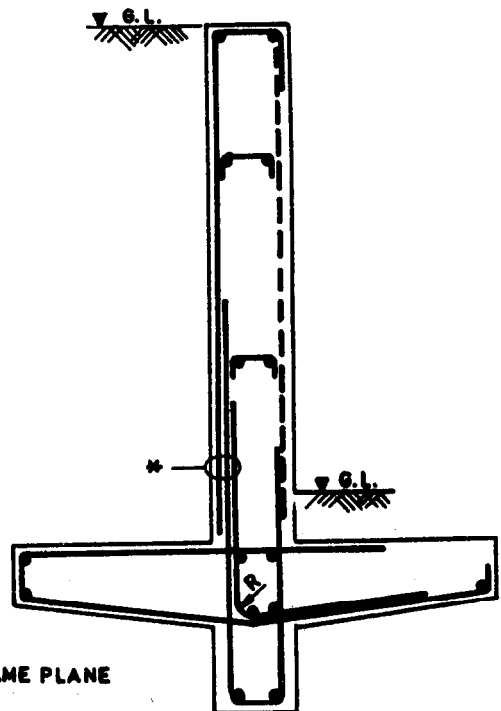

FIG. 11.10 T-WALLS (DISTRIBUTION BARS OMITTED FOR CLARITY)

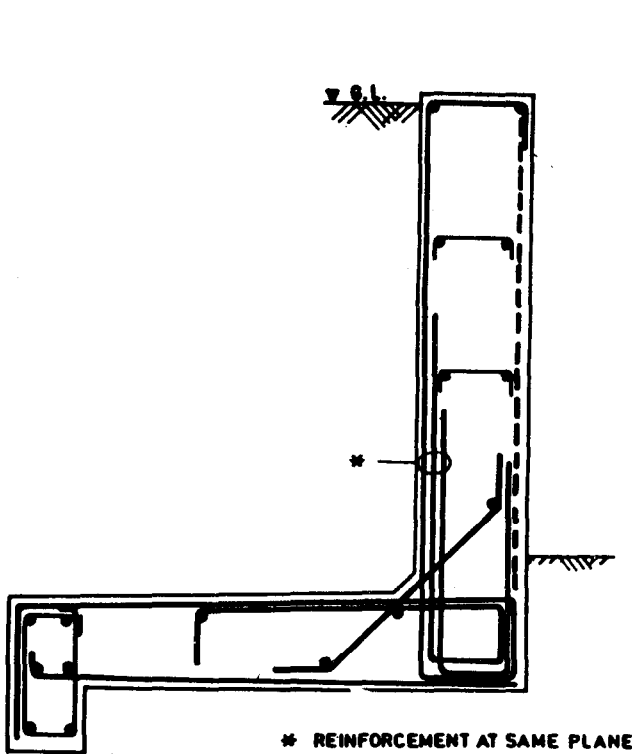

FIG. 11.11 REVERSED L-BASES (DISTRIBUTION BARS OMITTED FOR CLARITY)

- m) Note that the radius of bends for the main tensile bars is critical and should be at least 7.5 bar diameters.
- n) If problems are encountered in the accommodation of bars at the intersection of the base and wall, consider reducing the bar diameters and increasing the member thickness.
- p) Kicker height below ground level should be a minimum of 150 mm.
- q) Full contraction joints should only be used when it is predicted that shortening along the full length of the wall will be cumulative. Where necessary they should be detailed at 30 m centres. Movement joints should only be used when there is a risk of differential settlement between adjacent members.

11.3.1 Counterfort Retaining Wall — Figure 11.13 shows an elevation and section of a typical counterfort retaining wall illustrating general arrangement of reinforcement.

As with the wall part, the bars projecting from the base into the counterfort act as starter bars and must be of sufficient length to allow for lapping. These bars will normally be U-shaped. The wall is anchored to the counterfort by extending the binders from the counterfort into the wall. Opportunity has also been taken in Fig. 11.13 of showing the steel arrangement in the wall where it is anchored to the counterfort. It will be

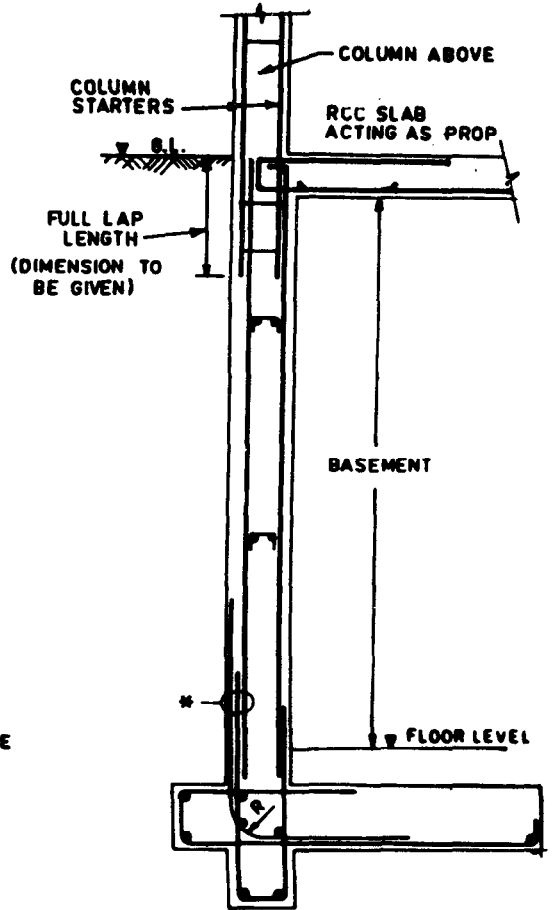

FIG. 11.12 PROPPED RETAINING WALLS

seen that the arrangement is exactly the same as for a continuous floor slab supported on beams, the beams being on the opposite side of the wall to that of the counterforts.

11.4 Shell and Folded Plate Structures

11.4.1 General — Shells and folded plates belong to the class of stressed skin structures which, because of their geometry and small flexural rigidity of the skin, tend to carry loads primarily by direct stresses acting on their plane. Different types of reinforced concrete shell and folded plate structures are in use in present day building practice for a variety of applications and give roofing of large column-free areas.

Cylindrical type shells are relatively common although shells of double curvature with the exception of domes have been introduced lately into building construction. However their use is limited as they demand exceptionally high degree of workmanship and costly formwork.

Folded plate structures are composed of rectangular plates/slabs connected along the edges in such a way as to develop special rigidity

of component parts. Their structural behaviour consists of transverse slab action by which the loads are carried to the joints, and longitudinal plate action by which they are finally transmitted to the transverses. Because of its great depth and small thickness, each plate offers considerable resistance to bending in its own plane.

Folded plates are often competitive with shells for covering large column free areas. They usually

consume relatively more materials compared to shells, but this disadvantage is often offset by the simpler formwork required for their construction. The added advantage of folded plate design is that its analysis is simpler compared to that of shells.

For detailing of reinforcement in shells and folded plates, the provisions of 'IS : 2210-1962 Criteria for the design of reinforced concrete shell structures and folded plates' are normally followed.

11.4.2 Diameter and Spacing of Reinforcement — The following diameters of bars may be provided in the body of the shell/plate. Large diameters may be provided in the thickened portions. Reinforcement in the form of welded wire fabric may also be used to satisfy design requirements:

- a) Minimum diameter : 6 mm
- b) Maximum diameter:
 - 1) 10 mm for shells between 4 and 5 cm in thickness,
 - 2) 12 mm for shells between 5 and 6.5 cm in thickness, and
 - 3) 16 mm for shells above 6.5 cm in thickness.

The maximum spacing of reinforcement in any direction in the body of the shell/plate shall be limited to five times the thickness of the shell and in the area of unreinforced panels to 15 times the square of thickness.

The cover requirements to reinforcement shall be as per slabs.

11.4.3 Reinforcement in Shells — The ideal arrangement would be to lay reinforcement in the shell to follow isotatics, that is, directions of the principal tensile stresses assumed to act at the middle surface of the plate. However, for practical purposes, one of the following methods may be used:

One is the diagonal grid at 45° to the axes of the shell, and in the other the rectangular grid in which the reinforcing bars run parallel to the edges of the shell. The rectangular grid needs additional reinforcement at 45° near the supports to take up the tension due to shear.

11.4.3.1 In the design of the rectangular grid for cylindrical shells, the reinforcement shall be usually divided into the following three groups:

- a) Longitudinal reinforcement to take up the longitudinal stress T_x ;
- b) Shear reinforcement to take up the principal tension caused by shear S ; and
- c) Transverse reinforcement to resist T_y and M_y .

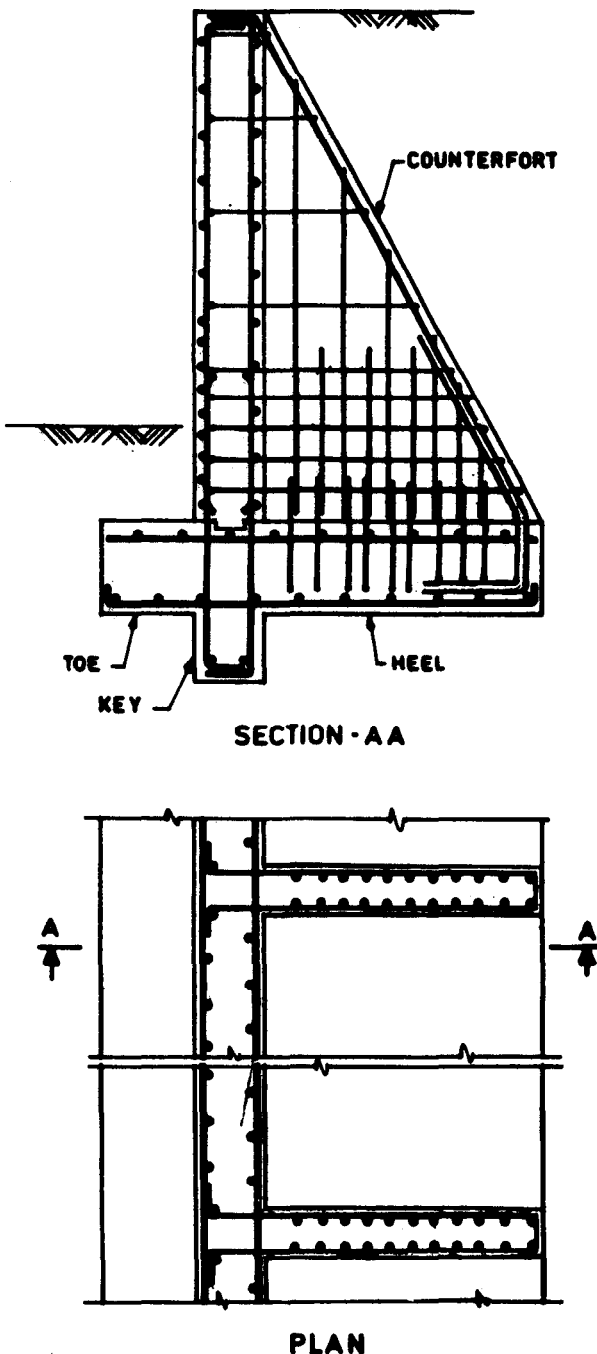
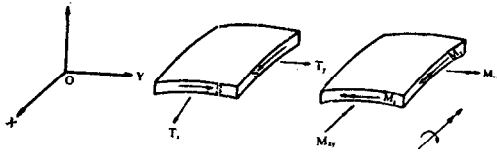

FIG. 11.13 TYPICAL DETAILS OF A COUNTERFORT RETAINING WALL



11.4.3.2 Longitudinal reinforcement shall be provided at the junction of the shell and the traverse to resist the longitudinal moment M_x . Where M_x is ignored in the analysis, nominal reinforcement shall be provided.

11.4.3.3 To ensure monolithic connection between the shell and the edge members, the shell reinforcement shall be adequately anchored into the edge members and traverses or *vice-versa* by providing suitable dowel bars from the edge members and traverses to lap with the shell reinforcement.

11.4.3.4 *Thickness* — Thickness of shells shall not be normally less than 50 mm if singly curved and 40 mm if doubly curved. Shells are usually thickened to some distance from their junction with edge members and traverses. The thickening is usually of the order of 30 percent of the shell thickness. In the case of singly curved shells, the distance over which the thickening is made should be between $0.38\sqrt{Rd}$ and $0.76\sqrt{Rd}$, where R and d are the radius and thickness, respectively. For double curved shells, this distance will depend upon the geometry of the shell and boundary conditions.

11.4.4 Reinforcement in Folded Plates

11.4.4.1 *Transverse reinforcement* — Transverse reinforcement shall follow the cross-section of the folded plate and shall be designed to resist the transverse moment.

11.4.4.2 *Longitudinal reinforcement* — Longitudinal reinforcement, in general, may be provided to take up the longitudinal tensile stresses in individual slabs. In folded plates which are like beams, the longitudinal reinforcement may be provided for the overall bending moment on the span treating the folded plate as a beam. The section of the concrete and transverse reinforcement at the joint shall be checked for shear stress caused by edge shear forces.

11.4.4.3 Reinforcement bars shall preferably be placed, as close as possible so that the steel is well distributed in the body of the slab. Nominal reinforcement consisting of 10 mm bars may be provided in the compression zones at about 20 cm centre-to-centre.

11.4.4.4 *Thickness* — The thickness of folded plates shall not normally be less than 75 mm. It is sometimes advantageous, while using the trough shape, to make the horizontal plates thicker than the inclined ones.

11.4.5 Typical details of placing reinforcement in shells and folded plates are shown in Fig. 11.14 to 11.17.

11.5 Reservoirs and Tanks — The reservoirs and tanks for storage of liquids can be square, rectangular, circular or hexagonal in plan with a roof over them. One of the important detailing considerations is the sealing of the construction joints and the same should be detailed on the drawing. The grade of concrete below M 20 shall not be used for sections of thickness equal to or less than 450 mm. Tanks shall generally be designed as uncracked section.

11.5.1 *Cover* — Minimum cover to reinforcement of members on faces either in contact with the liquid or enclosing space above the liquid (such as inner face of roof slab), should be 25 mm or the diameter of the main bar, whichever is greater. In the presence of sea water, soils and water of corrosive character, the cover shall be increased by 12 mm but this additional cover should not be taken into account for design calculations.

11.5.1.1 For faces away from the liquid and for parts of the structure not in contact with the liquid, the cover shall conform to requirements of Section 4.

11.5.2 *Minimum Reinforcement* — The minimum reinforcement in walls, floors and roofs in each of two directions at right angles shall have an area of 0.3 percent of the concrete section in that direction for sections up to 100 mm thick. For sections of thickness greater than 100 mm and less than 450 mm the minimum reinforcement in each of the two directions shall be linearly reduced from 0.3 percent for 100 mm thick section to 0.2 percent for 450 mm thick section. For sections of thickness greater than 450 mm, minimum reinforcement in each of the two directions shall be kept at 0.2 percent. In concrete sections of thickness 225 mm or greater, two layers of reinforcement shall be placed one near each face of the section to make up the minimum reinforcement.

11.5.2.1 The minimum reinforcement specified in 11.5.2 may be decreased by 20 percent in case of high strength deformed bars.

11.5.2.2 In special circumstances such as tanks resting on ground floor slabs, percentage of steel less than that specified above may be provided.

11.5.3 Joints

11.5.3.1 *General* — This clause defines the types of joint which may be required in liquid-retaining structures. The types of joints are illustrated in Fig. 11.18 and are only intended to be diagrammatic. The location of all joints should be decided by the engineer and shall be detailed on the drawings.

11.5.3.2 Types of joint

a) *Construction joint* — A construction joint is a joint in the concrete introduced for

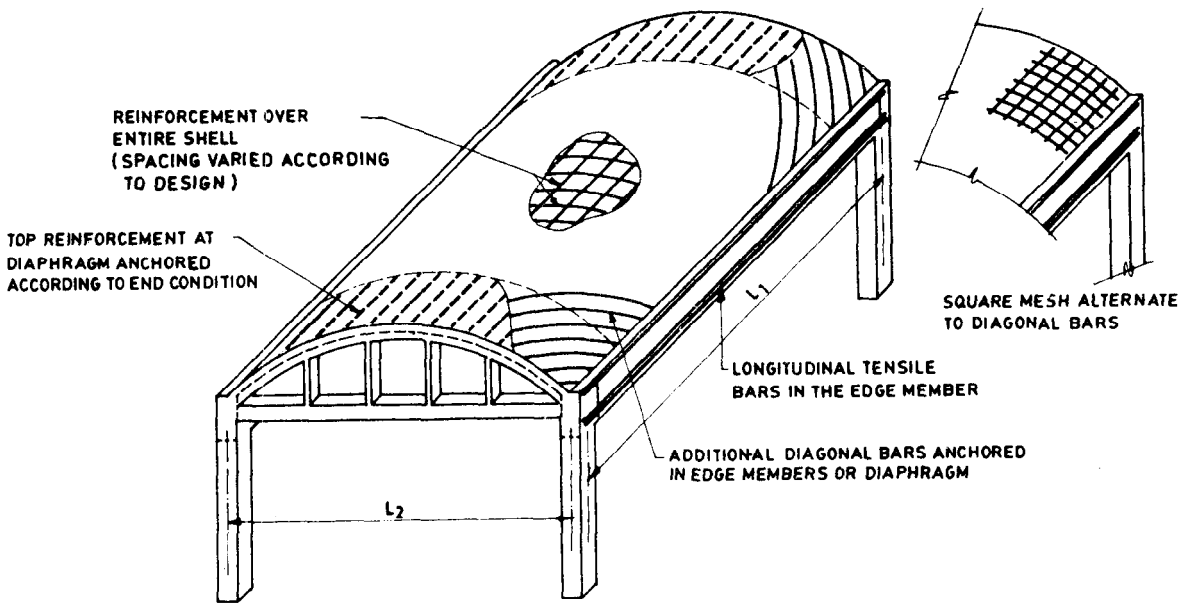

11.14A ISO METRIC VIEW OF A BARREL SHELL

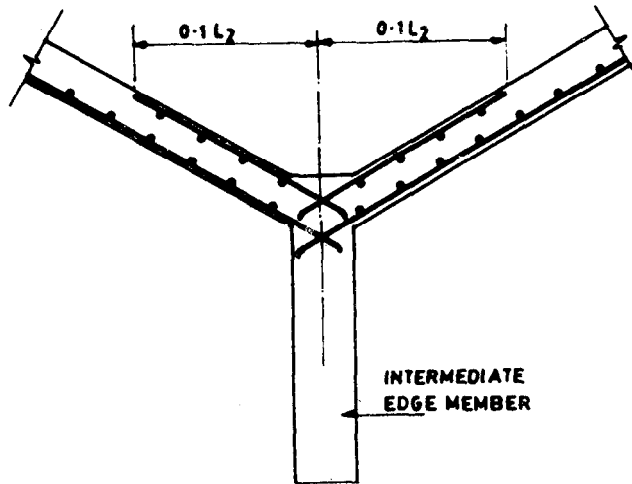

11.14B REINFORCEMENT NEAR AN INTERMEDIATE EDGE MEMBER

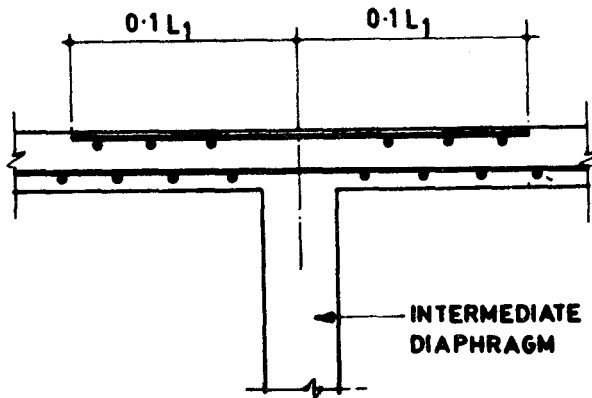

11.14C REINFORCEMENT NEAR AN INTERMEDIATE DIAPHRAGM

FIG. 11.14 TYPICAL MANAGEMENT OF BARS IN A LONG BARREL SHELL

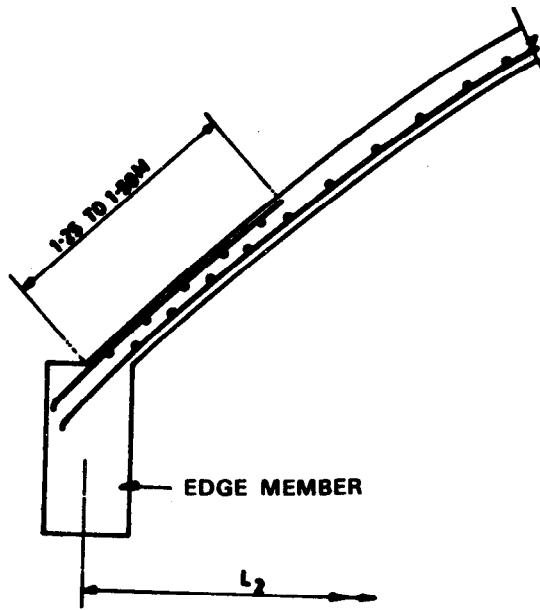

11.15A AT EDGE MEMBERS

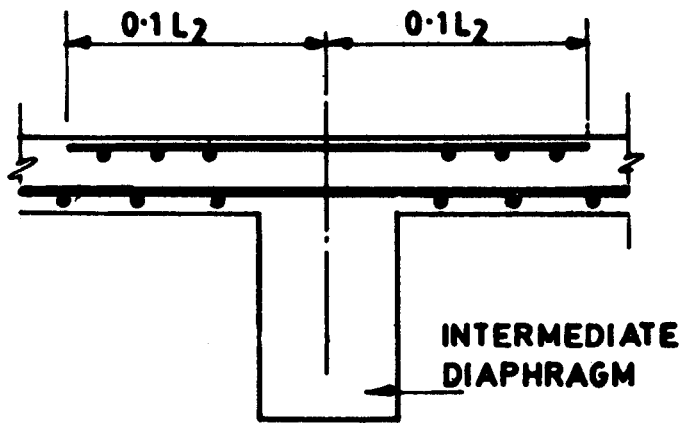

11.15B ABOVE INTERMEDIATE DIAPHRAGMS

FIG. 11.15 TYPICAL DETAILS OF A SHORT BARREL SHELL

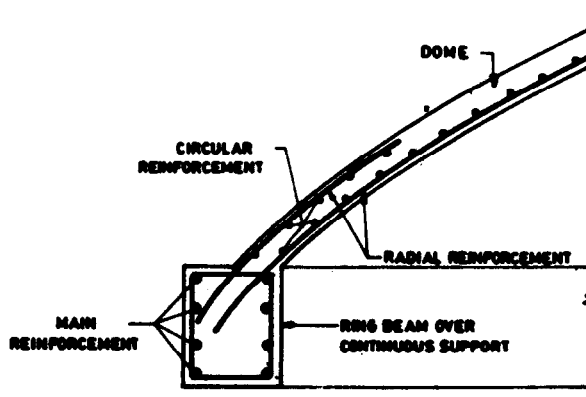
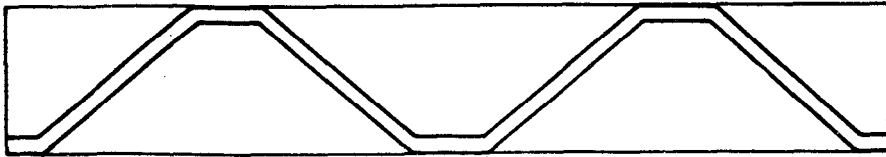
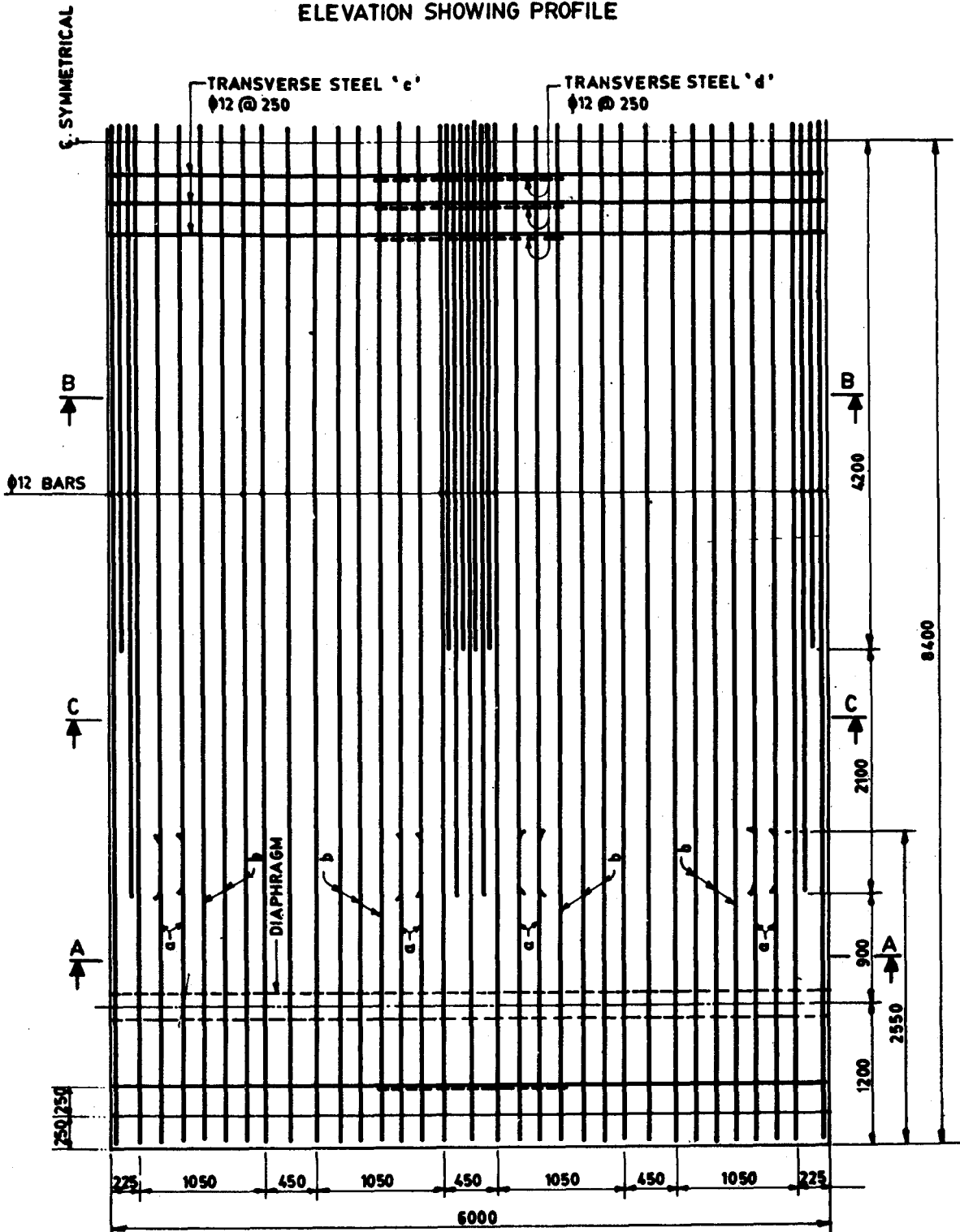

FIG. 11.16 REINFORCEMENT IN A DOME



ELEVATION SHOWING PROFILE



HALF PLAN OF FOLDED PLATE ROOF

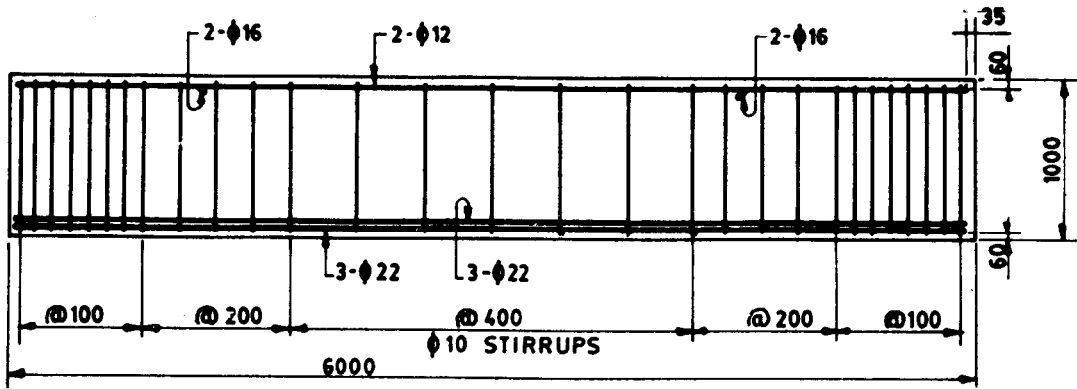

SECTIONAL ELEVATION OF DIAPHRAGM

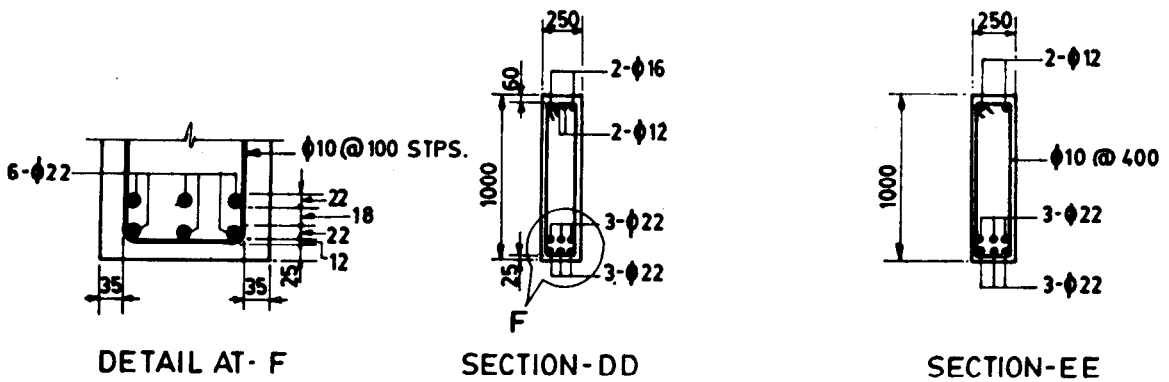

DETAIL AT- F

SECTION-DD

SECTION-EE

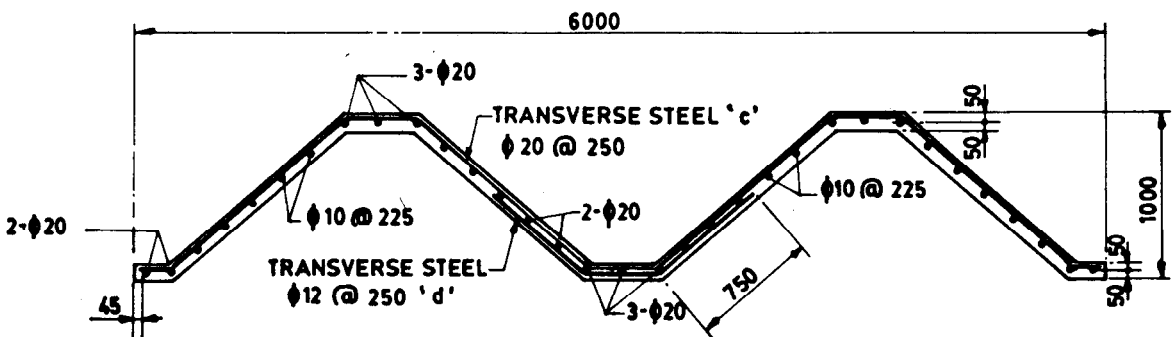

SECTION-AA

FIG. 11.17A

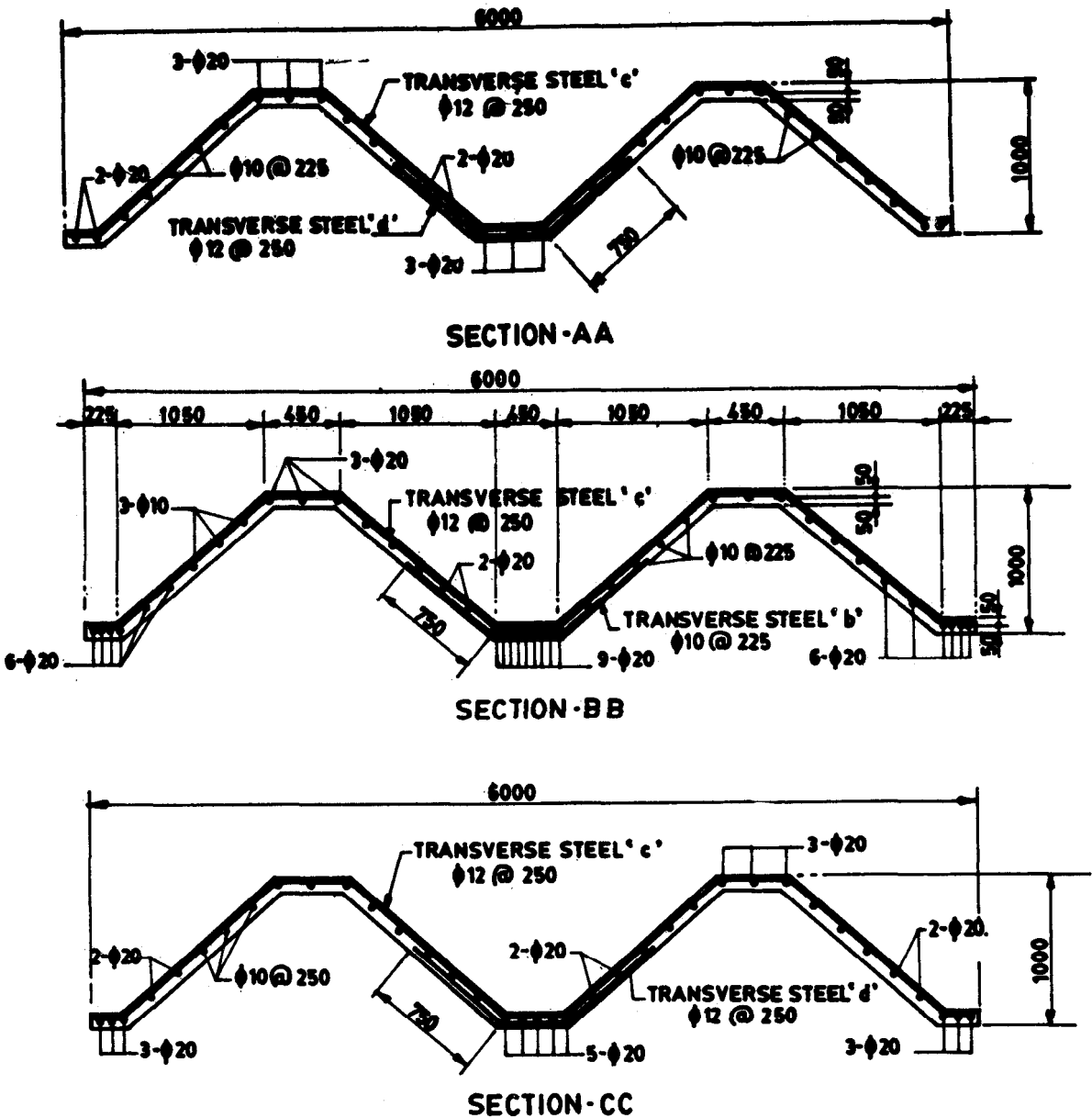

FIG. 11.17

convenience in construction at which measures are taken to achieve subsequent continuity with no provision for further relative movement. A typical application is between two successive lifts in a tank wall (see Fig. 11.18A).

b) *Movement joint*—A movement joint is a specially formed joint intended to accommodate relative movement between adjoining parts of a structure, special provision being made for maintaining the water-tightness of the joint. Movement joints may be of the following types:

1) *Contraction joint*—This is a movement joint which has a deliberate discontinuity

but no initial gap between the concrete on both sides of the joint. The joint is intended to permit contraction of the concrete.

A distinction should be made between a complete contraction joint (see Fig. 11.18C), in which both the concrete and reinforcement are interrupted, and a partial contraction joint (see Fig. 11.18B), in which only the concrete is interrupted while the reinforcement is continued through the joint.

2) *Expansion joint*—This is a movement joint which has complete discontinuity in

both reinforcement and concrete and is intended to accommodate either expansion or contraction of the structure (see Fig. 11.18D).

- 3) *Sliding joint* — This is a movement joint which has complete discontinuity in both reinforcement and concrete. Special provision is made to facilitate relative movement in the plane of the joint. A typical application is between wall and floor in some cylindrical tank designs.

11.5.4 Rectangular Tanks

11.5.4.1 General — Rectangular water tanks are generally analyzed in accordance with IS : 3370 (Part 4)-1967 Code of practice for concrete structures for storage of liquids: Part 4 Design tables'. This code gives tables for moment coefficients and shear coefficients for fixed wall panels along vertical edges but having different end conditions at top and bottom. In arriving at these coefficients, the slabs have been assumed to act as thin plates under various edge conditions given in the code.

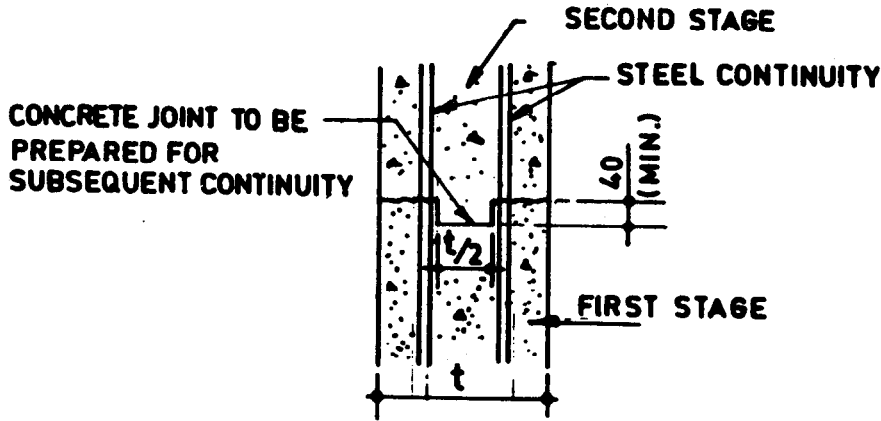
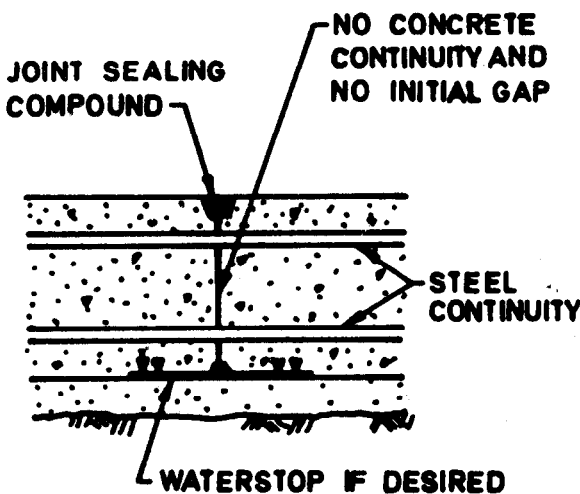
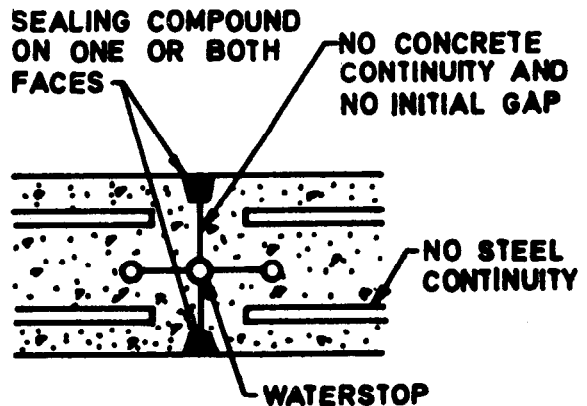

FIG. 11.18A A CONSTRUCTION JOINT



11.18B PARTIAL CONTRACTION JOINT



11.18C COMPLETE CONTRACTION JOINT

FIG. 11.18 TYPES OF JOINTS (TO ILLUSTRATE BASIC PRINCIPLES) (Continued)

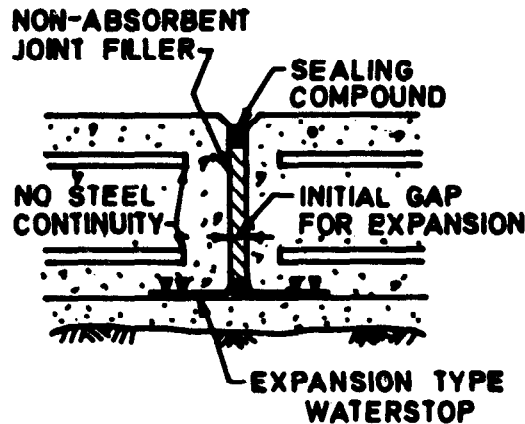

11.18D EXPANSION JOINT

FIG. 11.18 TYPES OF JOINT (TO ILLUSTRATE BASIC PRINCIPLES)

In the plan, the corners restrain the walls under pressure from their tendency to bend outward (see Fig. 11.19). This produces tension zones as shown in Fig. 11.19, at the middle of each outer face of wall and on each side of corners on inner wall faces. These tension portions shall be provided with horizontal steel in addition to that required to reinforce the vertical cantilever effect of walls. The general arrangement of bars in a rectangular tank resting on beams is shown in Fig. 11.20.

When the tank is below ground, the dispersion of steel in the wall depends on the bending moment diagram for internal water pressure and external earth/water pressure.

11.5.4.2 Base reinforcement — The bottom slab of a tank resting on ground shall be doubly reinforced with horizontal reinforcement at the top and bottom of the slab. This is required to cater for the downward pressure when reservoir is full and upward ground pressure when empty. A typical reinforcement detail is shown in Fig. 11.21. The use of dowel bars (starter bars) to the walls shall depend on whether the tank is shallow or deep.

The main and distribution bars in the base shall be placed as per slabs. If the walls are high and long then counterfort or buttress walls shall be used.

11.5.4.3 Roof joint — To avoid the possibility of sympathetic cracking, it is important to ensure that movement joints in the roof correspond with those in walls if roofs and walls are monolithic. If, however, provision is made by means of a sliding joint for movement between the roof and the wall, correspondence of joints is not so important.

11.5.5 Circular Tanks — Circular water tanks are generally analyzed in accordance with IS : 3370 (Part 4)-1967. This code gives tables for moment coefficients and shear coefficients for different end conditions at top and bottom.

11.5.5.1 Wall reinforcement — The horizontal hoop reinforcement in the circular tanks are provided either in one layer (for small tanks) or in two layers (for large tanks). Typical details are shown in Fig. 11.22.

The spacing of hoop reinforcement is increased from bottom to top of the wall to allow for reduction in pressure. Practically it can be varied at every 1.0 to 1.2 m.

The maximum and minimum spacing of the hoop steel and the proportions of distribution steel used will be similar to that of floor slab. The wall thickness shall be taken as equivalent to the floor thickness. The laps shall be provided in the main hoop steel in accordance with Section 4. For continuity of reinforcement between the base and the wall diagonal corner reinforcement shall be provided.

11.5.5.2 Base reinforcement — The base of the circular tank shall be doubly reinforced to resist the downward pressure when full and upward soil pressure when empty.

The best reinforcement for the base is a square mesh fabric and this does not require a detailed plan. When base reinforcement is provided with corner bars, the details of reinforcement shall be shown giving details of corner bars (see Fig. 11.23).

It shall be advisable to specify that main bars in the top layer shall be placed at right angles to

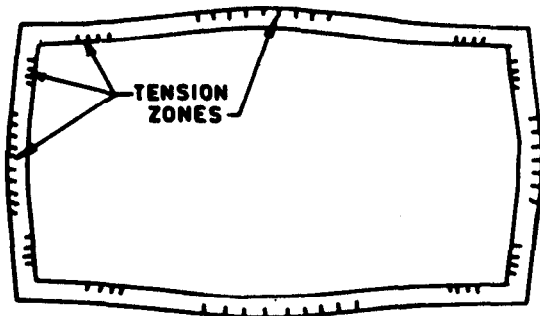
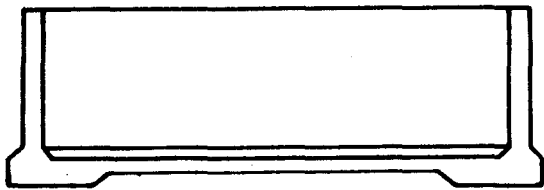

FIG. 11.19 SKETCH SHOWING DEFORMATION OF RECTANGULOR TANK UNDER INTERNAL PRESSURE

those in the bottom layer and that the position of overlaps, if required, will be staggered.

11.5.6 Overhead Tanks—Circular and Intze—A water tower is a typical type of the overhead tank. The only difference between this type of tank and one constructed at ground level, is in the method of support.

11.5.6.1 Roofs—The reservoirs and tanks shall be provided with roof and will be detailed as a normal slab supported on beams and columns or a flat slab supported on columns alone.

In a reservoir that is roofed over, it is possible that the side walls may not act as a cantilever walls but as vertical slabs like basement walls. Then the walls shall be detailed as a slab spanning vertically between the reservoir base and roof. Figure 11.24 shows the typical arrangement of bars (cross-section) in a Intze tank.

11.6 Reinforced Concrete Hinges—Many reinforced concrete structures, such as bridges and portal frames, are designed on the premise that parts of the structure act as hinges. In very large structures, the use of a normal metal hinge would be very expensive and it is, therefore, more economical to form a hinge using reinforcing bars. This is possible because the actual rotation required to satisfy the condition is very small.

11.6.1 Figure 11.25 gives details of three typical RC hinges used at supports.

11.6.1.1 Figure 11.25A is a type of reinforced concrete hinge suitable for a large portal frame or vertical support to a long bridge. The resilient material placed between the member and its foundation can be bituminous felt, lead, rubber or plastic. When the type of hinge is detailed make sure that the hinge reinforcing bars are adequately held in place by binders or hoops as shown. Also the area of concrete marked *A* is sufficient to transfer the whole of the compressive force from the member to the foundation.

The Mesnager hinge shown in Fig. 11.25B has a short portion reduced in cross-section to about one-third of the width. The narrow concrete section is heavily reinforced, and provided with closely spaced binders or hoops. The considered hinge has spiral reinforcement as shown in Fig. 11.25C. If the section of the hinge is wide then extra spirals must be detailed. The gap formed between the abutment and the member is filled with suitable flexible material.

11.6.2 Crown Hinges—These are inserted into certain types of arch structures known as three-hinges, or pinned arches. Figure 11.26 gives general details for this type of hinge.

In the Mesnager hinge shown in Fig. 11.26B, the main reinforcement crosses at an angle of 60° and the gap is filled with a waterproof, resilient material. The joint develops considerable resistance against thrust and shear, yet has little resistance to rotation. Figure 11.26C shows a modification to the Mesnager type of hinge—the considered hinge. This only acts as a hinge during the construction of the arch. When the formwork is removed and the arch drops slightly under its own action the main reinforcing bars are welded together and the hinge is concreted in to form a permanent joint.

11.7 Concrete Pipes—Reinforced cement concrete pipes are widely used for water mains, sewers, culverts and in irrigation. When used for carrying highly acidic sewage or industrial wastes, necessary precautions shall have to be taken against chemical attack and corrosion.

Reinforced concrete pipes either spun or cast shall be designed such that the maximum tensile stress in the circumferential steel due to the specified hydrostatic test pressure does not exceed the limit of 125 N/mm² in the case of mild steel rods, 140 N/mm² in the case of cold-drawn steel wires and high strength deformed bars/wires.

The barrel thickness shall be such that under the specified hydrostatic test pressure, the maximum tensile stress in concrete when considered as effective to take stress along with the tensile reinforcement shall not exceed 2 N/mm² but the wall thickness shall not be less than those given in IS : 458-1971 'Specification for precast concrete pipes (with and without reinforcement (second revision))'.

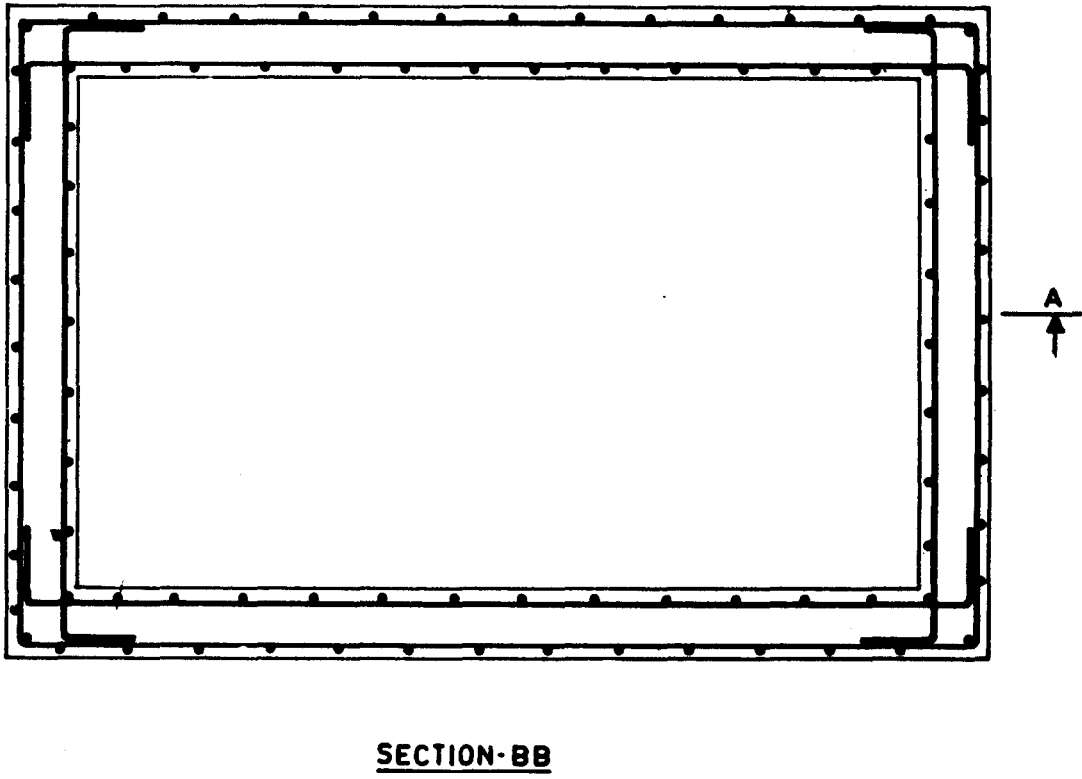
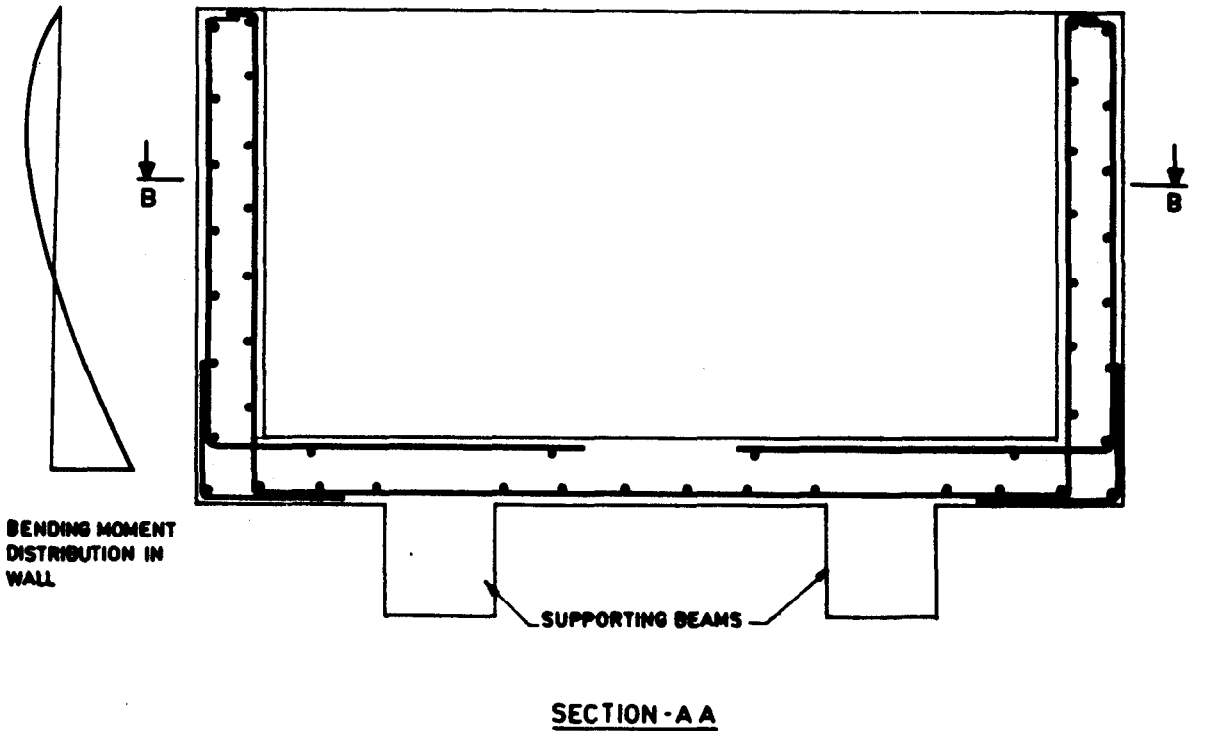

FIG. 11.20 RECTANGULAR TANK SUPPORTING ON BEAMS GENERAL ARRANGEMENT OF REINFORCEMENT

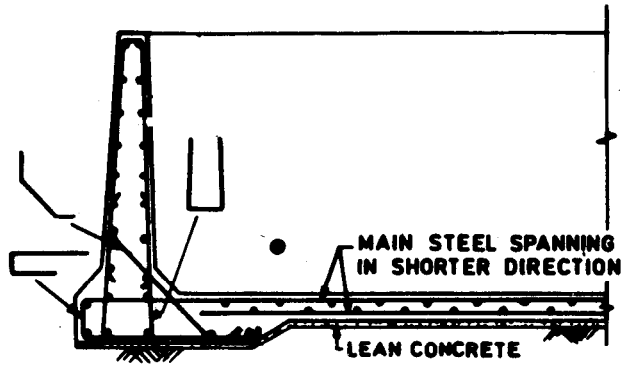
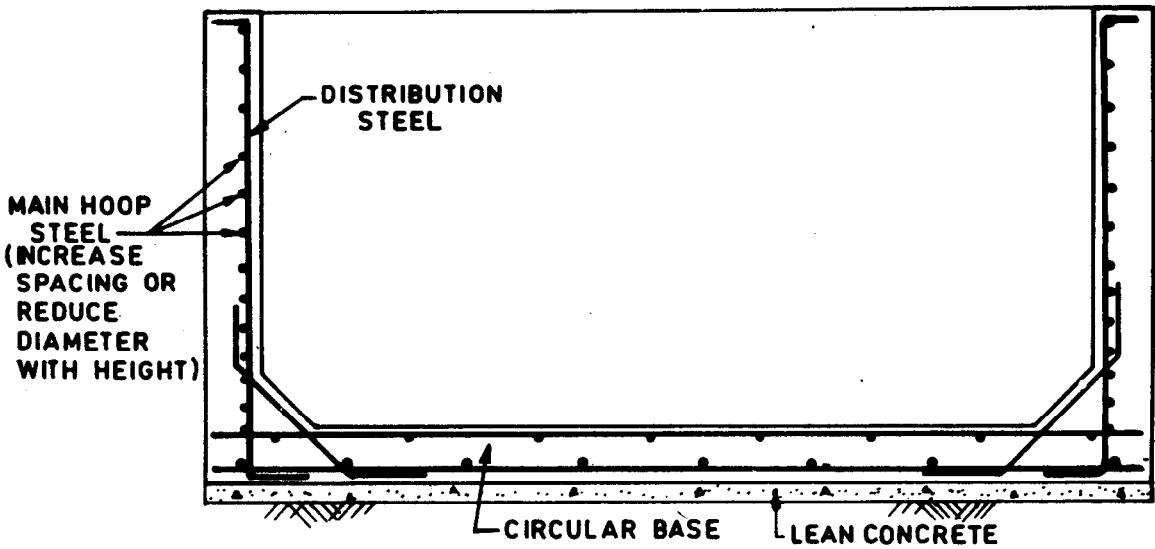
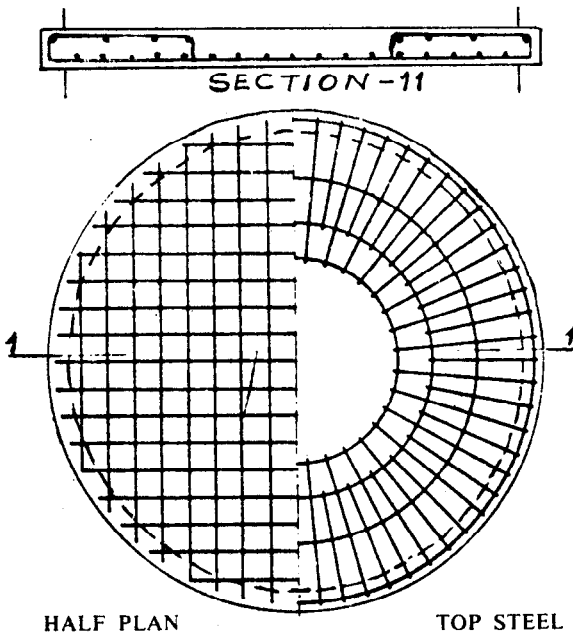

FIG. 11.21 RECTANGULAR TANK RESTRAINED AT BASE WITH THICKENING AT THE BASE— TYPICAL CROSS SECTION



11.22A SECTION THROUGH A CIRCULAR TANK WITH HOOP REINFORCEMENT IN A SINGLE LANGER



11.22B CIRCULAR SLABS
FIG. 11.22 CIRCULAR TANK

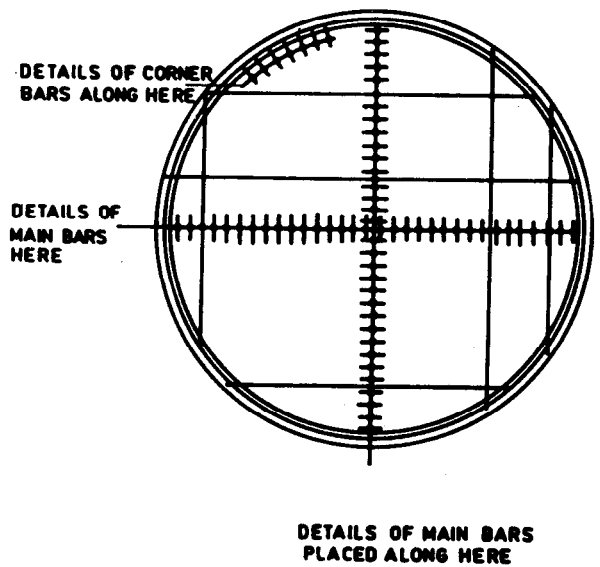

FIG. 11.23 TYPICAL ARRANGEMENT OF BARS IN A CIRCULAR BASE

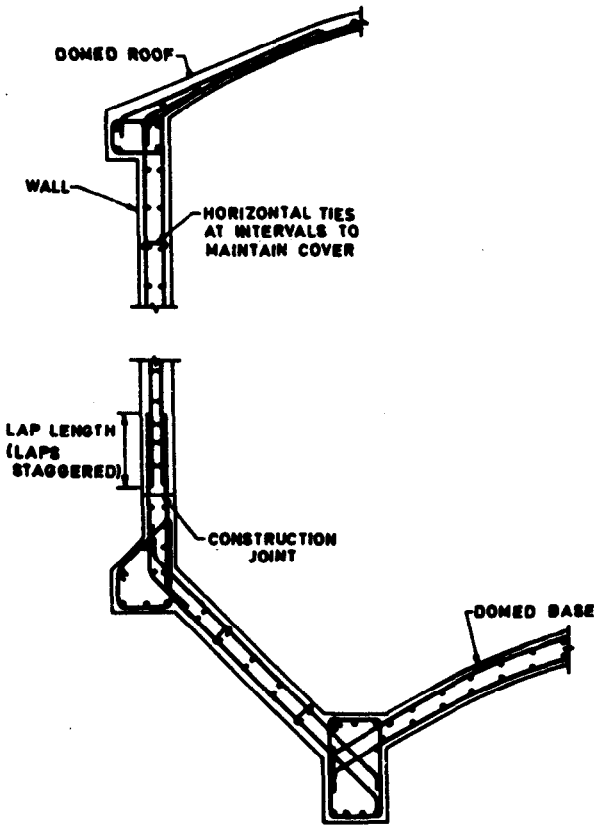

FIG. 11.24 TYPICAL ARRANGEMENT OF BARS IN A INTZE TANK

11.7.1 Reinforcement — The reinforcement (circumferential and longitudinal) shall extend throughout the length of the pipe. The pitch of the circumferential reinforcement shall be neither more than 10 cm or four times the thickness of barrel, whichever is less, nor less than the maximum size of aggregate plus the diameter of the bar used. There is no internationally accepted design method for concrete pipes. Design had to be based on both practical experience and theory. Accordingly minimum quantity of steel has been specified in IS : 458-1971. All pipes with wall thickness 75 mm and above shall have double reinforcement cage and the amount of hoop steel in the outer cage shall be 75 percent of the mass of the hoop steel in inner cage.

NOTE — The ends of concrete pipes shall be suitable for butt, flush collar, spigot and socket, rebated or flexible rubber ring joints. All pressure pipes shall have flexible rubber ring joint. Dimensions of collars shall be according to IS : 458-1971. The reinforcement for the collars shall be same as that provided in the nearest nominal bore of the pipe and the longitudinal reinforcement shall be proportional to the length of the collar. The collars shall be spun up to 1200 mm diameter pipes. Rebated joints shall be used in case of pipes having wall thickness of 110 mm or more.

A typical arrangement of reinforcement is shown in Fig. 11.27.

NOTE — Diagonal reinforcement may be provided at 15 percent of longitudinals in pipes for which the cages are not welded so as to help in binding the cage securely.

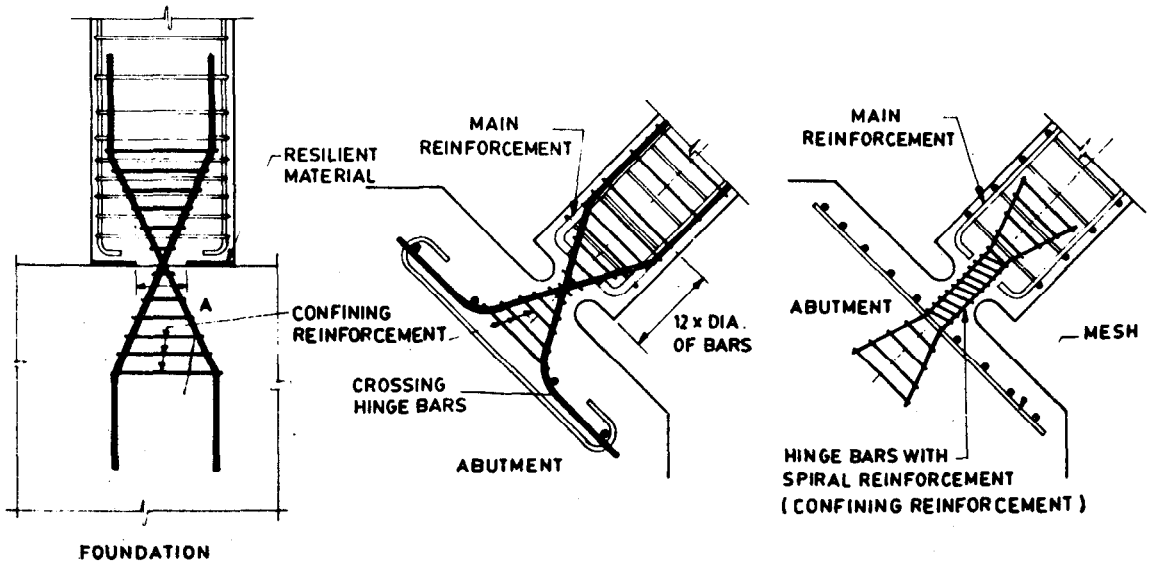
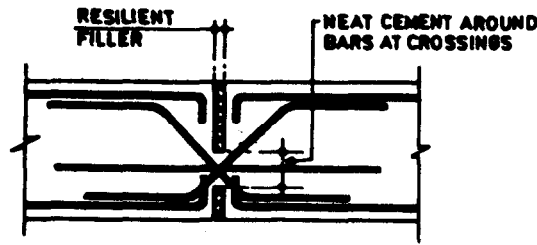
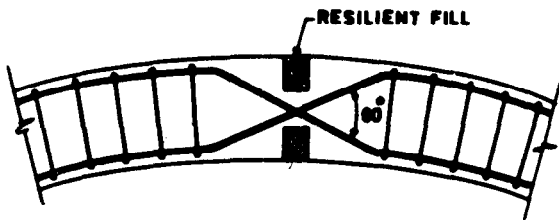

FIG. 11.25 REINFORCED CONCRETE HINGES AT SUPPORTS



11.26A



11.26B

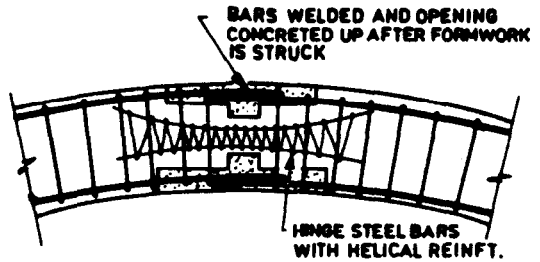

11.26C

FIG. 11.26 CROWN HINGES

11.7.2 Cover— Clear cover to any reinforcement should not normally be less than the following:

| Barrel Thickness mm | Nominal Clear Cover mm |
|--------------------------------|------------------------------|
| Up to and including 25 | 6 |
| Over 25 up to and including 30 | 8 |
| Over 30 up to and including 75 | 10 |
| Over 75 | 15 |
| As spigot steps | 6 |

NOTE— For class NP4 pipes (in accordance with IS : 458-1978, the minimum cover shall be 20 mm.

11.8 Machine Foundations

11.8.1 Foundations for Impact Type Machines (Hammer Foundations) [IS : 2974 (Part 2)-1980 'Code of Practice for Design and Construction of Machine Foundations: Part 2 Foundations for Impact Type Machines (Second Revision)']—The foundation block should be made of reinforced concrete. It is desirable to cast the entire foundation block in one operation. If a construction joint is unavoidable, the plane of the joint shall be horizontal and measures shall be

taken to provide a proper joint. The following measures are recommended:

Dowels of 12 or 16 mm diameter should be embedded at 60 mm centres to a depth of at least 300 mm at both sides of the joint. Before placing the next layer of concrete, the previously laid surface should be roughened, thoroughly cleaned, washed by a jet of water and then covered by a layer of rich 1 : 2 cement grout (1 cement : 2 sand), 2 cm thick. Concrete should be placed not later than 2 hours after the grout is laid.

11.8.1.1 Reinforcement shall be placed along the three axis and also diagonally to prevent shear failure (see Fig. 11.28). Additional reinforcement shall be provided at the top side of the foundation block than at the other sides. Reinforcement at the top may be provided in the form of layers of grills made of 16 mm diameter bars suitably placed to allow easy pouring of concrete. The topmost layers of reinforcement shall be provided with a cover of at least 5 cm. The reinforcement provided shall be at least 25 kg/m³ of concrete.

Figure 11.28 shows typical reinforcement details of a hammer foundation block.

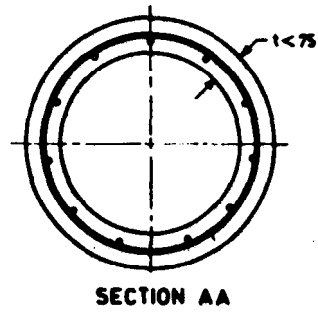
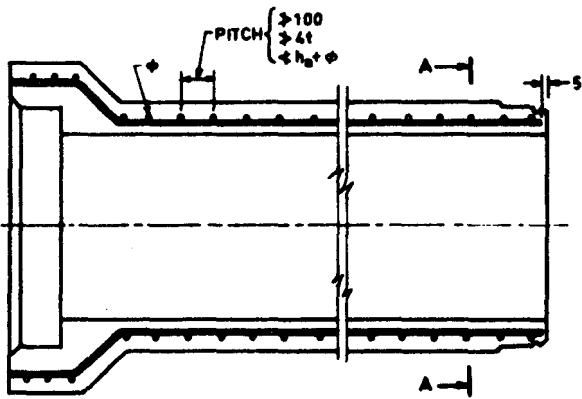

11.27A SINGLE LAYER

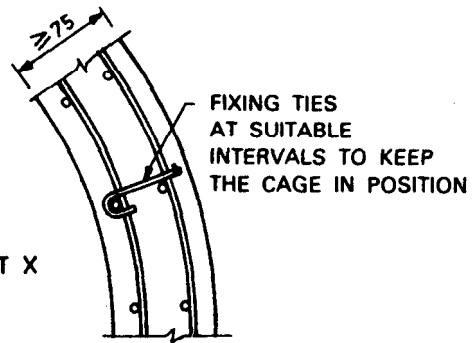
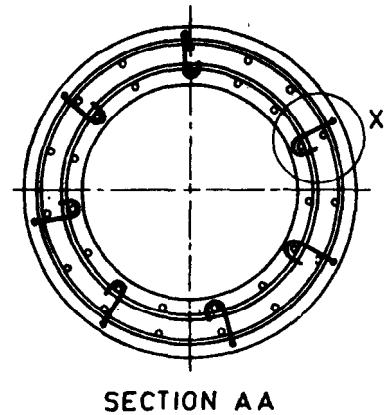
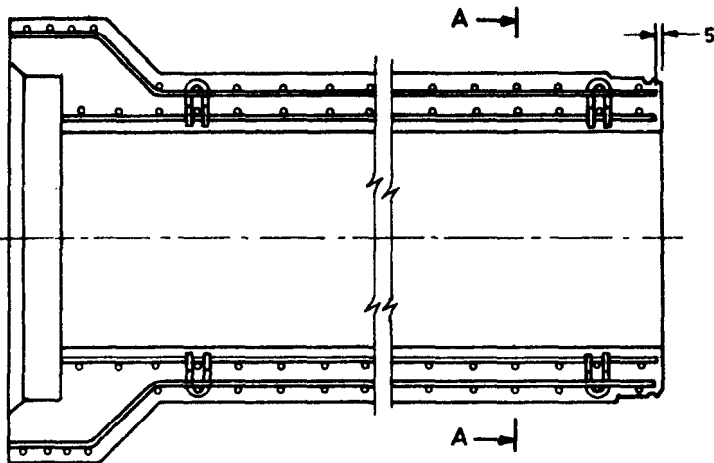

11.27B DOUBLE LAYER

FIG. 11.27 TYPICAL DETAILS OF PIPES

11.8.2 Foundations for Rotary Type Machines of Low Frequency [IS : 2974(Part 4)-1979] — The amount of minimum reinforcement for block foundation shall be 25 kg/m³ of concrete. The amount of minimum reinforcement for frame foundations shall be 40 kg/m³ of concrete for

base slab, 70 kg/m³ of concrete for columns and 90 kg/m³ of concrete for top slab.

Stirrups suitably spaced shall be provided to tie together the main longitudinal bars.

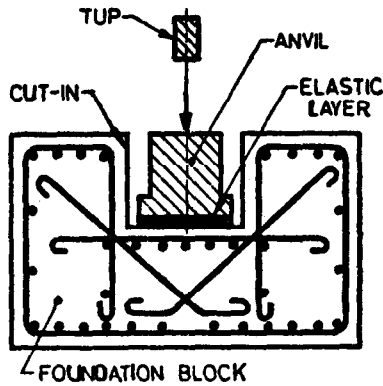

FIG. 11.28 TYPICAL REINFORCEMENT DETAIL

The minimum diameter of the mild steel bars shall be 12 mm and the maximum spacing shall be 200 mm.

The concrete cover for protection of reinforcement shall be 75 mm at the bottom, 50 mm on sides and 40 mm at the top.

Typical arrangement of reinforcements are shown in Fig. 11.29 to 11.31.

11.8.3 Foundations for Reciprocating Type Machines [IS : 2974 (Part 1)-1982].

11.8.3.1 Minimum reinforcement in block foundations—Minimum reinforcement in the concrete block shall be not less than 25 kg/m³. For machines requiring special design considerations of foundations, like machines pumping explosive gases, the reinforcement shall be not less than 40 kg/m³.

The minimum reinforcement in the block shall usually consist of 12 mm bars spaced at 200/250 mm centre-to-centre extending both vertically and horizontally near all the faces of the foundation block.

11.8.3.2 The following points shall be considered while arranging the reinforcements:

- a) The ends of mild steel (if used) shall always be hooked irrespective of whether they are designed for tension or compression;
- b) Reinforcement shall be used at all faces;
- c) If the height of foundation block exceeds one metre, shrinkage reinforcement shall be placed at suitable spacing in all three directions; and
- d) Reinforcement shall be provided around all pits and openings and shall be equivalent to 0.50 to 0.75 percent of the cross-sectional area of the opening.

A typical arrangement of reinforcement in a reciprocating machine foundation is shown in Fig. 11.32.

11.8.4 Foundations for Rotary Type Machines (Medium and High Frequency) [IS : 2974 (Part 3)-1975 'Code of Practice for Design and Construction of Machine Foundations: Part 3 Foundation for Rotary Type of Machines (Medium and High Frequency) (First Revision)].

11.8.4.1 The vertical reinforcing bars of the column shall have sufficient embedment in the base slab to develop the required stresses.

11.8.4.2 All units of foundation shall be provided with double reinforcement. Reinforcements shall be provided along the other two sides of cross-sections of beams and columns, even if they are not required by design calculations so that symmetric reinforcement will be ensured in opposite sides.

11.8.4.3 The amount of minimum reinforcement for major structures components of the framework shall be as follows:

- a) Base slab 40 kg/m³ of concrete
- b) Columns 70 kg/m³ of concrete
- c) Top table 90 kg/m³ of concrete (slab and beam)

Typical arrangement of reinforcement is shown in Fig. 11.33.

11.8.4.4 Stirrups suitably spaced shall be provided to account for the entire shear in the foundation elements.

11.8.4.5 The minimum diameter of longitudinal steel for beams and columns should be selected so that the maximum spacing of these bars shall not be more than 150 mm.

11.8.4.6 Reinforcement cover—Unless specified otherwise, the concrete cover for reinforcement protection shall be as follows:

- a) Base slab 100 mm for top, bottom and sides
- b) Columns and pedestals 50 mm on sides
- c) Beams 40 mm on sides

11.8.4.7 Minimum grade of concrete for foundation shall be not less than M20.

11.8.4.8 Construction joints—The base slab shall be cast in a single pour. A properly designed construction joint shall be provided between the base slab and the columns.

Wherever intermediate decks exist and construction joints are to be provided, the subsequent set of construction joints shall be provided at the top of each such intermediate deck.

In case there is no intermediate deck, continuous concreting shall be done for the columns and the upper deck.

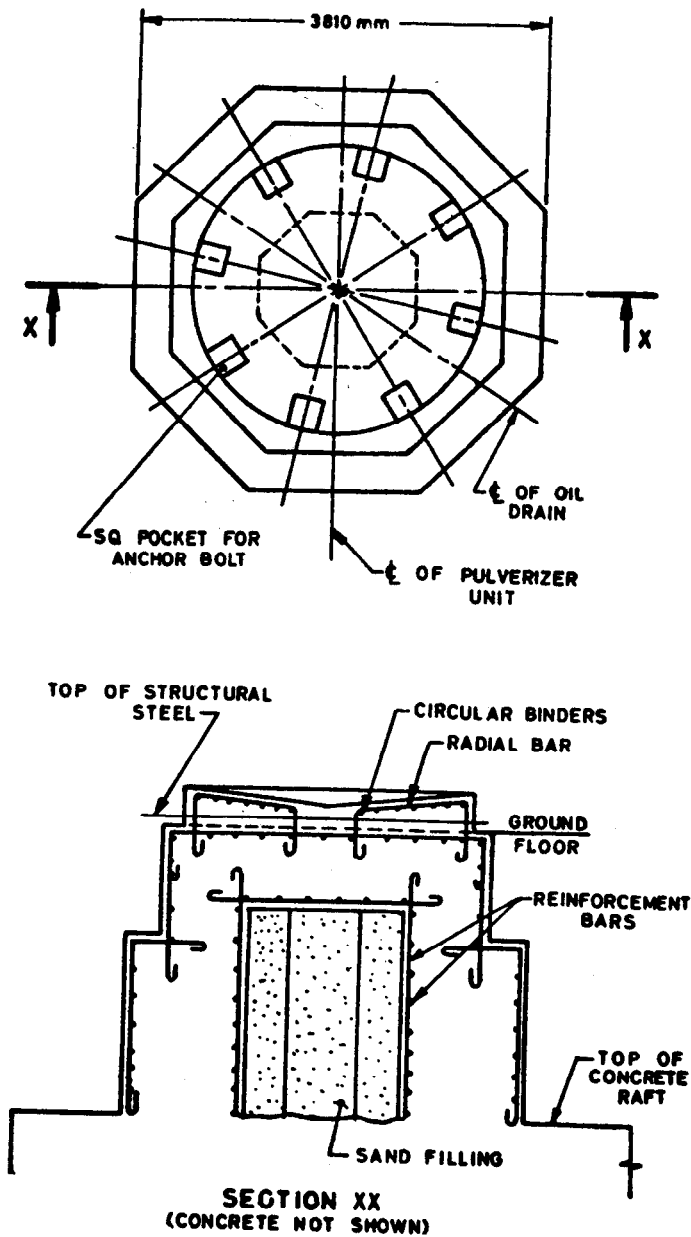

FIG. 11.30 TYPICAL FOUNDATION FOR CRUSHING MILL (PULVERIZER UNIT)

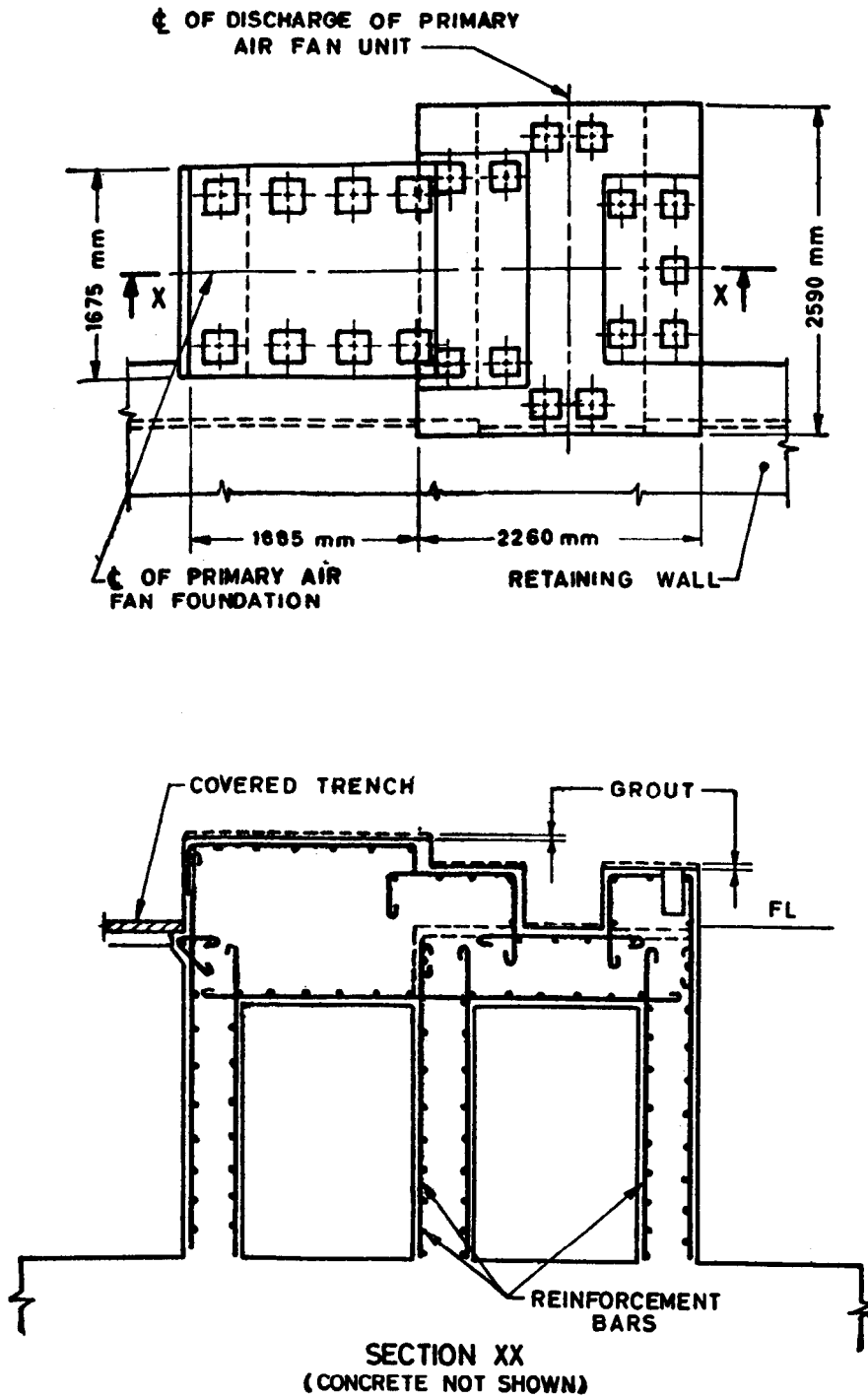

FIG. 11.31 TYPICAL FOUNDATION FOR PRIMARY AIR FAN

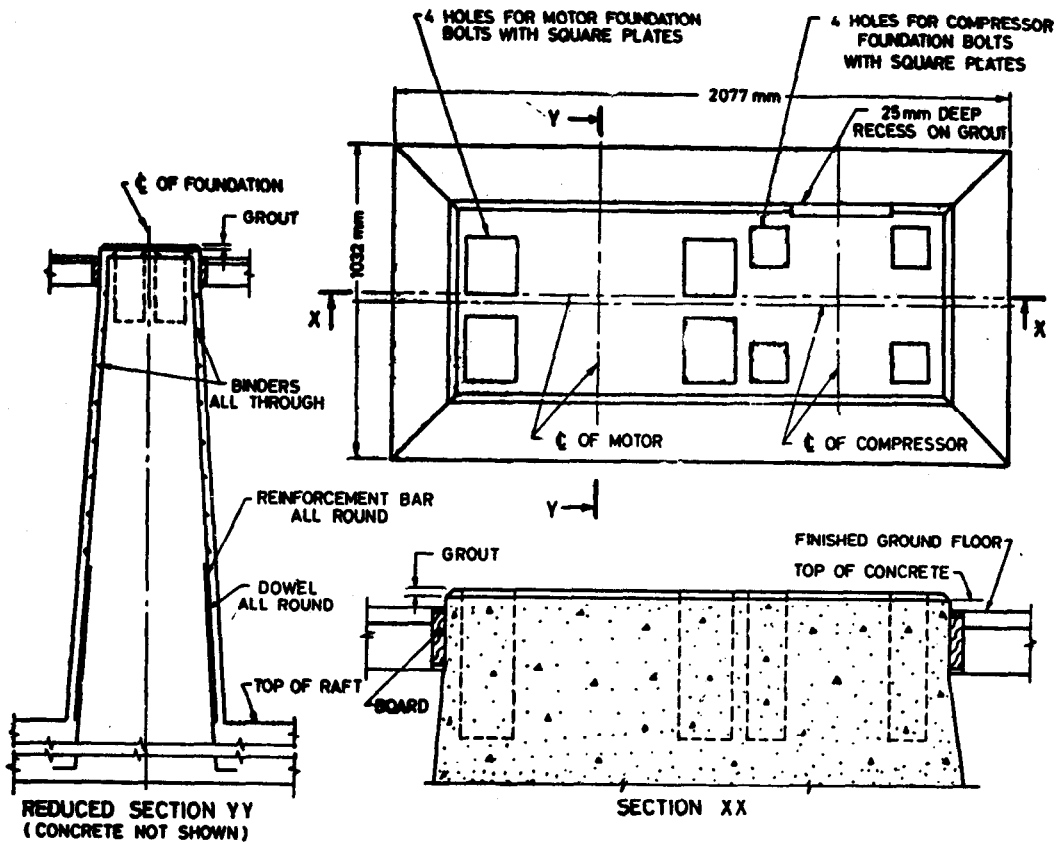
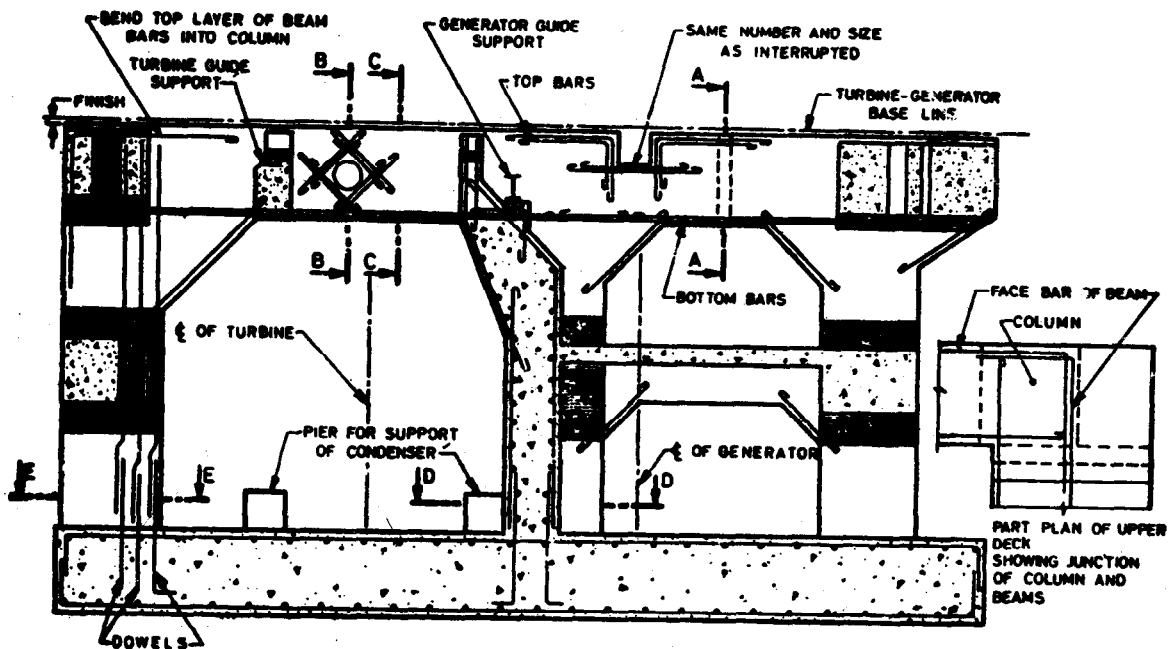
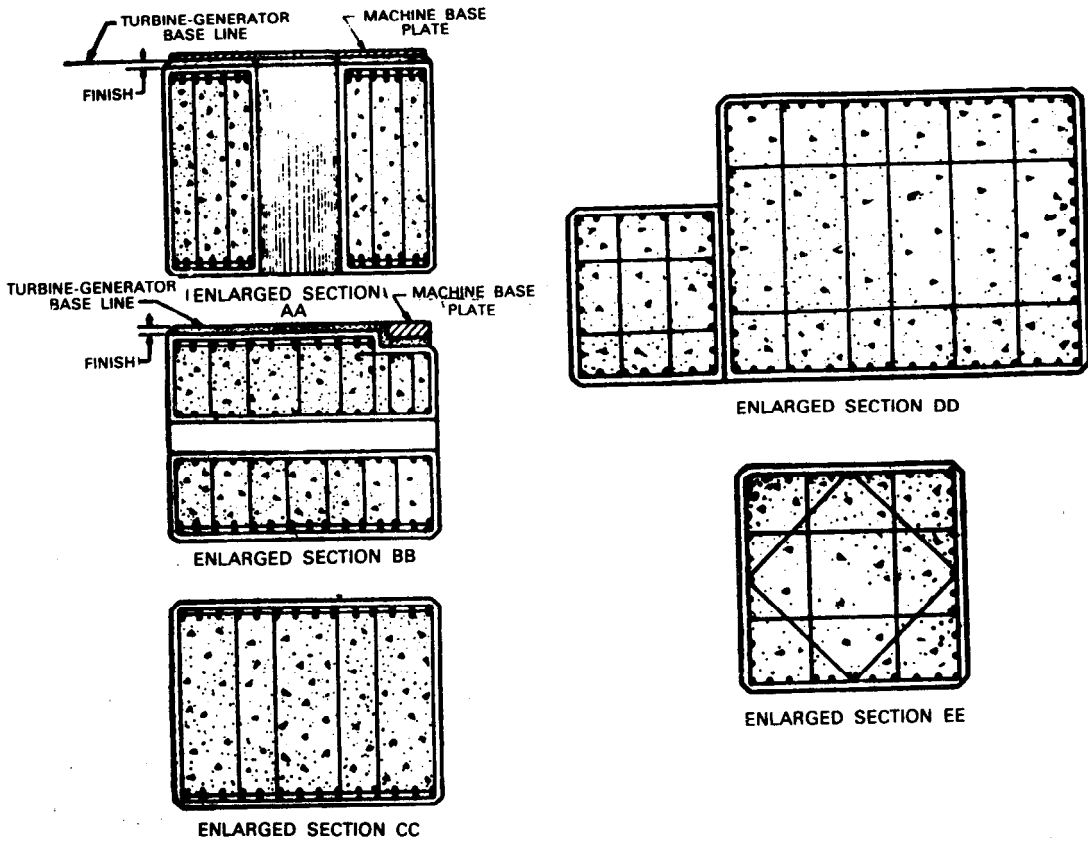

FIG. 11.32 TYPICAL FOUNDATION FOR INSTRUMENT AIR COMPRESSOR



11.33A TYPICAL LONGITUDINAL SECTION THROUGH A TURBO GENERATOR FOUNDATION

FIG. 11.33 TYPICAL DETAILS OF A TURBO GENERATOR FOUNDATION (Continued)



11.33B TYPICAL REINFORCEMENT OF BEAMS

11.32C TYPICAL REINFORCEMENT OF COLUMNS

FIG. 11.33 TYPICAL DETAILS OF A TURBO GENERATOR FOUNDATION

SECTION 12

Ductility Requirements of Earthquake Resistant Buildings

SECTION 12

DUCTILITY REQUIREMENTS OF EARTHQUAKE RESISTANT BUILDINGS

12.0 General—The primary members of structure such as beams and columns are subjected to stress reversals from earthquake loads. The reinforcement provided shall cater to the needs of reversal of moments in beams and columns, and at their junctions.

Earthquake motion often induces forces large enough to cause inelastic deformations in the structure. If the structure is brittle, sudden failure could occur. But if the structure is made to behave ductile, it will be able to sustain the earthquake effects better with some deflection (Δm) larger than the yield deflection (Δy) by absorption of energy. Therefore, besides the design for strength of the frame, ductility is also required as an essential element for safety from sudden collapse during severe shocks. It has also been observed during past earthquakes that structures designed and built for low seismic coefficients survived severe earthquakes with little damage because of energy absorption in plastic deformations.

In zones where risk of major damage from earthquake loads is possible, ductile frame is required in accordance with IS : 4326-1976 'Code of practice for earthquake resistant design and construction of buildings (*first revision*)'. These provisions are generally applicable to all seismic zones but its importance is greater where severe earthquake loadings will become much more significant than other concurrent loads. Accordingly the Code makes it obligatory that in all cases where the design seismic coefficient [see IS : 1893-1976 'Criteria for earthquake resistant design of structures (*third revision*)'] is 0.05 or more (which invariably includes zones IV and V) ductility provisions specified in IS : 4326-1976 shall be adopted. The ductility requirements will be deemed to be satisfied if the conditions given in the following clauses are achieved.

12.1 Flexural Members

12.1.1 The top as well as bottom steel reinforcement shall consist of at least two bars each throughout the length of the member, and the steel ratio ρ on either face (both on compression and tension face) shall not be less than as given below:

For M 15 concrete and plain mild steel bars,
 $\rho_{\min} = 0.0035$

For other concrete and steel reinforcement, $\rho_{\min} = 0.06 F_c / F_y$

where

$$\rho = A_s / bd,$$

F_c = 28-day cube crushing strength of concrete,

F_y = yield stress of reinforcing steel,

A_s = area of steel on a face,

b = breadth of beam web, and

d = effective depth of section.

12.1.2 The maximum tensile steel ratio on any face at any section shall not exceed the following:

For M 15 concrete and plain mild steel bars,
 $\rho_{\max} = \rho_c + 0.011$

For other concrete and mild steel reinforcement, $\rho_{\max} = \rho_c + 0.19 F_c / F_y$

For concrete reinforced with coldworked deformed bars, $\rho_{\max} = \rho_c + 0.15 F_c / F_y$

where

ρ_c = actual steel ratio on the compression face.

12.1.3 When a beam frames into a column, both the top and bottom bars of the beam shall be anchored into the column so as to develop their full tensile strength in bond beyond the section of the beam at the face of the column. Where beams exist on both sides of the column, both face bars of beams shall be taken continuously through the column.

NOTE — To avoid congestion of steel in a column in which the beam frames on one side only, it will be preferable to use U-type of bars spliced outside the column instead of anchoring the bars in the column.

Figure 12.1 shows the typical detail for a beam framing into column from one side or two sides. Such an arrangement will ensure a ductile junction and provide adequate anchorage of beam reinforcement into columns. Top and bottom longitudinal steel for beams framing into both sides of column should extend through the column without splicing.

12.1.4 The tensile steel bars shall not be spliced at sections of maximum tension and the splice shall be contained within at least two closed stirrups (see Fig. 12.2).

12.1.5 The web reinforcement in the form of vertical stirrups shall be provided so as to develop the vertical shears resulting from all ultimate vertical loads acting on the beam plus those which

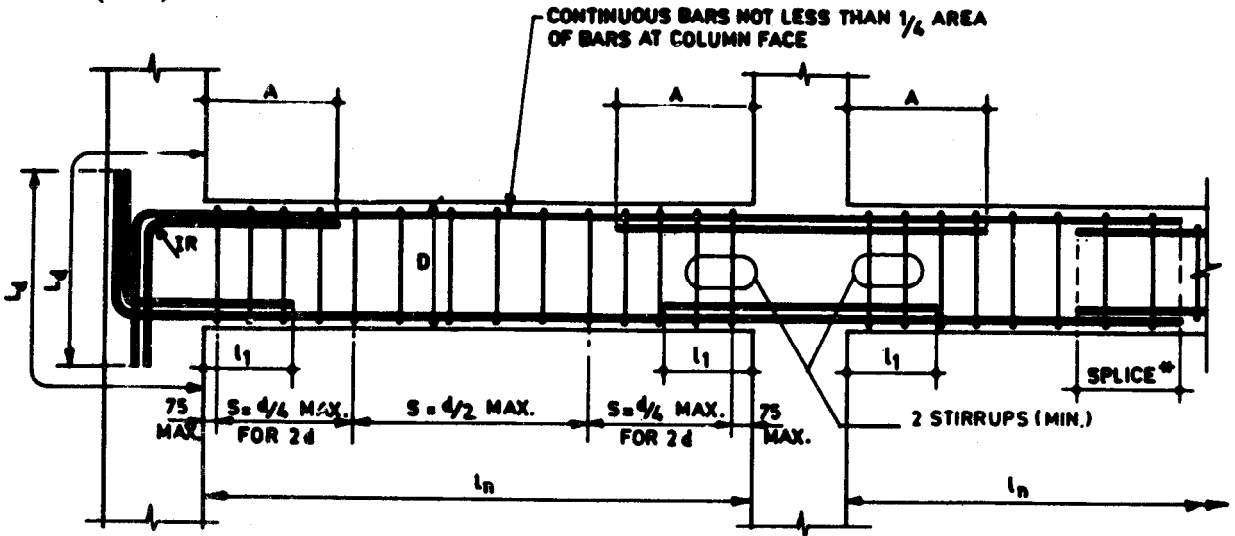

Designer should provide dimension *A*, *S*, *d*, anchorage length, cutoff points of discontinuous bars, etc.
 *provide not less than two stirrups throughout splice length.

- A* = distance to point of inflection plus anchorage length but not less than $l_n/4$. Designer may cut some bars shorter than this but at least one-third the area of bars at the face of column must extend this distance
- d* = Effective depth of beam
- IR* = Internal radius = 4 d_b minimum, 6 d_b preferable
- L_d = development length
- d_b = diameter of bar

FIG. 12.1 EXAMPLE OF TYPICAL BAR DETAILS FOR SPECIAL DUCTILE MOMENT RESISTING FRAMES (COLUMN DETAILS EXCLUDED)

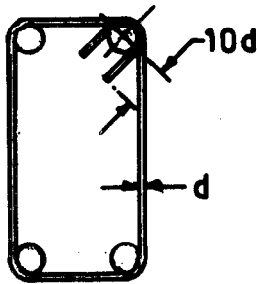

FIG. 12.2 CLOSED STIRRUPS

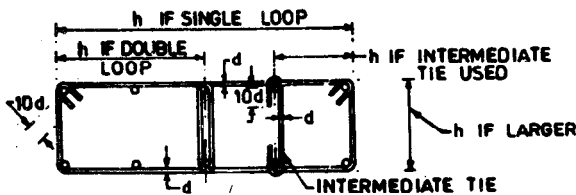

FIG. 12.3 DIMENSION *h* IN RECTANGULAR HOOP

can be produced by the plastic moment capacities at the ends of the beam. The spacings of the stirrups shall not exceed $d/4$ in a length equal to $2d$ near each end of the beam and $d/2$ in the remaining length (see Fig. 12.1). It is important to note that in no case shear failure should precede flexural failure.

12.1.6 Because of the possibility of reversal of shears in the beams, the earthquake shears shall be provided for by the vertical stirrups as they will be effective both for upward and downward shears. Where diagonal bars are also used, their

maximum shear carrying capacity will be restricted below 50 percent of the design shear. Closely spaced stirrups are preferable.

12.2 Columns. Subjected to Axial Load and Bending

12.2.1 If the average axial stress P/A on the column under earthquake condition is less than $0.1 F_c$, the column reinforcement will be designed according to requirements of flexural members given in 12.1. But if $P/A \geq 0.1 F_c$, special confining reinforcement will be required at the column ends as given in 12.2.2 to 12.2.4.

12.2.2 The cross-sectional area of the bar forming circular hoops or a spiral used for confinement of concrete will be:

$$A_{sh} = 0.08 s D_k \frac{F_c}{F_y} \left(\frac{A}{A_k} - 1 \right)$$

where

- A_{sh} = area of bar cross-section,
- s* = pitch of spiral or spacing of hoops,
- D_k = diameter of core measured to the outside of the spiral or hoop,
- F_c = 28-day cube crushing strength of concrete,
- F_y = yield stress of reinforcing steel (hoop or stirrups),
- A* = gross concrete area of the column section, and
- A_k = area of core = $\frac{\pi}{4} D_k^2$.

In the case of rectangular closed stirrups used in rectangular sections, the area of bar shall be:

$$A_{sh} = 0.16 s h \frac{F_c}{F_s} \left(\frac{A}{A_k} - 1 \right)$$

where

h = longer dimension of the rectangular confining stirrup, and

A_k = area of confined concrete core in the rectangular stirrup measured to its outside dimensions.

NOTE — The dimension h of the stirrup could be reduced by introducing links at intermediate points as shown in Fig. 12.3. In this case also A_k shall be measured as overall core area regardless of the stirrup arrangement. Each end of the intermediate tie shall engage the periphery hoop with a standard semicircular hook and shall be secured to a longitudinal bar to prevent displacement of the intermediate tie during construction.

12.2.3 The special confining steel, where required, shall be provided above and below the beam connections in a length of the column at each end which shall be the largest of:

- a) 1/6 of clear height of the column,
- b) larger lateral dimension of the column, and
- c) 450 mm.

The spacing of the hoops or closed stirrups used as special confining steel shall not exceed 10 cm (see Fig. 12.4 and 12.5).

12.2.4 Shear reinforcement shall be provided in the columns to resist the shear resulting from the lateral and vertical loads at ultimate load condition of the frame. The spacing of shear reinforcement shall not exceed $d/2$, where d is the effective depth of column measured from compression fibre to the tension steel.

12.3 Beam-Column Connections — Joints between exterior columns and adjoining flexural members shall be confined by transverse column reinforcement through the joint. Such reinforcement shall consist of circular hoops or spiral in the case of circular columns and rectangular closed stirrups in the case of rectangular columns, as required at the column ends. This is required because on exterior or corner columns the joint core is not confined by flexural members on all sides. To provide some measure of confinement in these situations giving some strength against brittle failure in the joint core, transverse reinforcement as required at the column ends is continued through the joint core (see Fig. 12.4 and 12.5).

The transverse reinforcement is required at the end of the column even if the column is confined

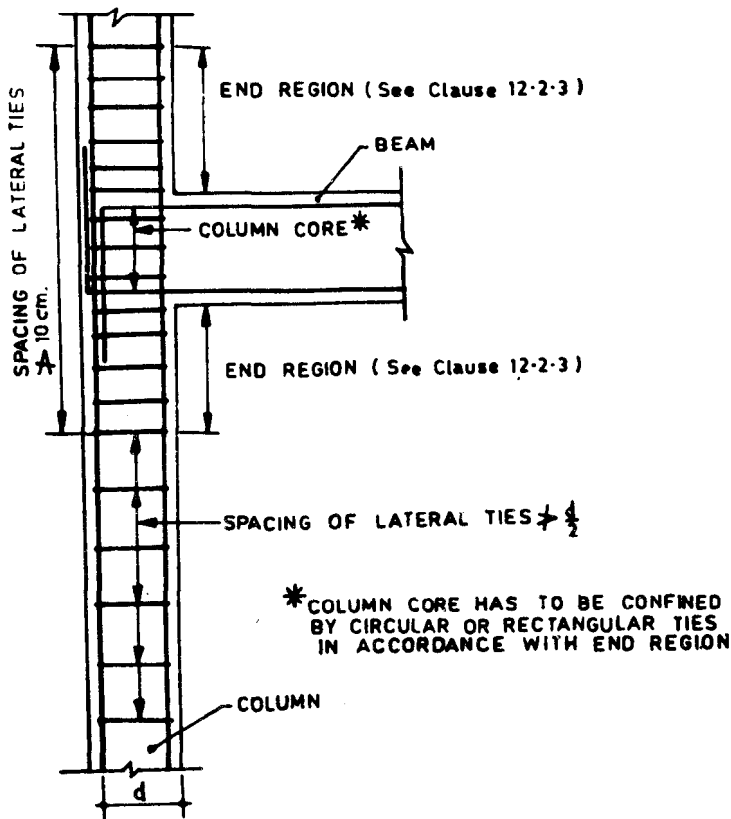

FIG. 12.4 BEAM COLUMN JOINT AT EXTERNAL COLUMNS

by beams from all four sides. The amount of transverse reinforcement in this case may be reduced to half the value. The tie reinforcement at beam-column joints may be provided by U-

shaped ties (hair pin type), the length of the legs beyond the columns being kept as dictated by bond requirements so as to develop full strength of the tie (see Section 7).

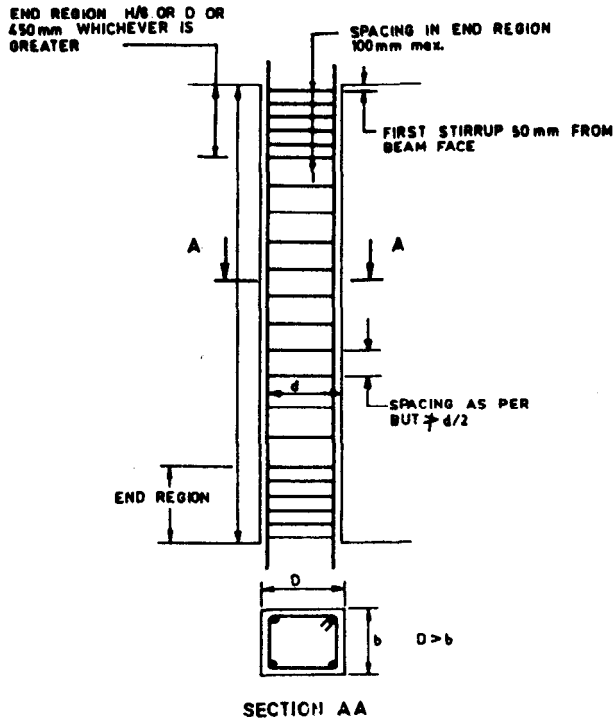

FIG. 12.5 SPACING OF SHEAR REINFORCEMENT IN COLUMNS

SECTION 13

**Transport, Storage, Fabrication, Assembly and
Placing of Steel Reinforcement**

SECTION 13

TRANSPORT, STORAGE, FABRICATION, ASSEMBLY AND PLACING OF STEEL REINFORCEMENT

13.1 Transport and Storage

13.1.1 Transport— This clause only concerns the transport of unshaped reinforcement. Reinforcement is to be protected during loading, unloading and transport. The following shall be avoided:

- a) Accidental damage or notches causing a decrease in section.
- b) Contact with other products liable to deteriorate or to weaken the bonding of the reinforcement.
- c) Any permanent bends in the reinforcement, straightening being inadvisable.
- d) Removal of any anti-corrosive protection present.

Care should be taken not to destroy the marking or labelling of the products. In order to facilitate any subsequent handling (unloading, distribution in the stock), batches of identical reinforcement should be grouped during transport.

13.1.1.1 Transport between the supplier and the consumer— Transport is generally by road. Wherever possible good accessibility to bundles of reinforcement should be maintained to allow rapid handling (separation timbers, slings). Unloading should be carried out mechanically wherever possible.

13.1.1.2 Transport on the fabrication area— The operation is generally expensive. However, rationalization and industrialization may lead to greater mass production which allows better use of mechanical lifting methods and reduces reliance on manual transport. Transport between various shaping machines may be carried out on tables fitted with rollers; these tables may be mobile and thus serve several production lines. Transport by lifting necessitates the use of a hoist fitted with several attachments for holding the bundle and preventing any permanent deformation in the reinforcement.

13.1.2 Storage— During storage, the reinforcement elements should be carefully indexed and classified according to their diameter, type, grades, length and batch of origin.

When the design of ribs or the distribution of the marking allows easy identification even for cut lengths, accidental substitution is not frequent; on the other hand, there is danger of confusion for plain reinforcement without markings or with

markings which are not repeated. It is thus necessary to use the entire length of the reinforcement or the cut reinforcement bearing the distinctive mark last of all. The cleanness of the steel without stains, such as grease, oil, paint, earth, non-adherent rust or any other substance which is harmful to its good preservation and bonding is important. The whole of protective coating, if any, shall be protected during storage and steel-fixing. When the reinforcement is removed from store, the surface state should be examined to ensure that the steel has not undergone any harmful deterioration. If the design engineer considers it necessary, the manufacturer (or the fabricator) shall carry out quality control tests.

This examination should be all the more detailed the longer the storage period, the more severe the environmental conditions, and higher the grade of steel.

Both on site (as far as possible) and in the works, a sufficient storage area should be provided to facilitate handling to prevent any error or confusion.

The storage area shall provide free access for the arrival of unbent reinforcement and be close to the measuring tables and other bending equipment. When a fabrication post is set up on site, but mainly during the design of larger reinforced units, any handling which is not strictly necessary shall be avoided wherever possible. As commercial lengths are large, any rotation of the reinforcement in a horizontal plane shall be excluded. This is possible when the reinforcement is stored in alignment or parallel to the measuring tables and the cutting tables.

13.2 Cutting— The reinforcement is cut in accordance with the cutting schedules. Cutting is carried out with the aid of shears power-operated or otherwise taking care not to damage the ribs in the neighbourhood of the sheared section.

Flame cutting and electrode cutting is not advised for reinforcement other than that in mild steel. It may alter the properties of heat-treated steel over a small length (a few diameters).

The cut lengths are generally measured on a measuring table; this ensures that flatness and straightness of the reinforcement are checked during measuring and the tolerances are complied with more easily.

For repetitive series, that is generally in factories, measuring tables are fitted with detachable stops, fixed in advance by the operator to obtain the desired lengths for several reinforcing bars simultaneously. Reinforcement on these measuring benches is transported by means of rollers, in some cases power-driven or by winches.

Tolerances on cut lengths depend on the tolerances for:

- a) the concrete cover to the reinforcement,
- b) the position of the reinforcement, and
- c) the structural element (shuttering).

Other tolerances may be imposed by special conditions:

- a) orthogonality of the sheared section in relation to the axis of the reinforcement (flash welding, sleeve splice), and
- b) absence of burns (sleeve splice).

Depending on the criteria of use, one may prefer one piece of cutting equipment to another (cutting by shears, cutting by power saw, etc).

13.3 Fabrication

13.3.1 General— Fabrication involves shaping of the reinforcement elements, that is, bending and radiusing (that is, bending with a large radius of curvature).

Fabrication is carried out in accordance with the schedules. The schedules shall be followed as strictly as possible; in fact, straightening is always hazardous, systematic rebending should, therefore, be avoided. It is advisable, if the bending has to be corrected *in-situ*, for this operation to be carried out by accentuating the bending rather than by straightening.

During fabrication, consideration shall be given to the fact that due to the elastic return of a bent bar, the real angle may (as function of the grade and diameter) be greater than the angle of rotation of the plate. The operator should therefore, overbend.

The minimum diameter of the mandrel shall be at least equal to the minimum diameter of the bending-rebending test specified in the Agreement, and shall be selected so as to avoid crushing or splitting of the concrete under the effect of the pressure which is exerted inside the curve.

For anchor hooks at the ends of the longitudinal bars, the minimum diameter of the mandrel shall never be less than 5ϕ . The fabricator shall ensure the quality of bending (absence of cracks, etc) by a visual examination.

In general, tolerances are not fixed on bending angles; on the other hand, it is important that the

overall dimensions of the fabricated reinforcement conform to the plan (correct placing, sufficient concrete cover, etc).

The bending speed depends on the nature of the steels and the ambient temperature: it shall be the subject of a preliminary experimental determination if it is not fixed in the Agreement or by the regulations.

Bending and radiusing, which are similar operations, are carried out cold. The use of a torch to facilitate this operation is generally prohibited, since it can, for example, alter the mechanical properties of cold worked steel.

Fabrication, even when mechanized, requires many operations: its relative importance in the overall cost of reinforcement is high. Rationalization of these operations and use to the greatest possible extent of rectilinear reinforcement are essential in order to reduce the overall cost.

13.3.2 Equipment— Bending of bars may be done either by improvised means or by hand-operated machines (see Fig. 13.1, 13.2 and 13.3) and by power-operated bender. For bars of 12 mm diameter and under, mechanical contrivances of the type illustrated in Fig. 13.1 may be advantageously employed.

13.3.2.1 Two of the most common types of bar-bending machines suitable for bending bars cold are shown in Fig. 13.2 and 13.3. The essential components of the machines are also illustrated in the figures. The hand machine shown in Fig. 13.2 could be employed for bending bars up to 16 mm diameter and for larger diameters geared bar bender shown in Fig. 13.3 is required. Special roller spindles may be necessary for bending deformed and twisted bars.

13.3.2.2 Bending of bars of 36 mm diameter and larger require special equipment, such as

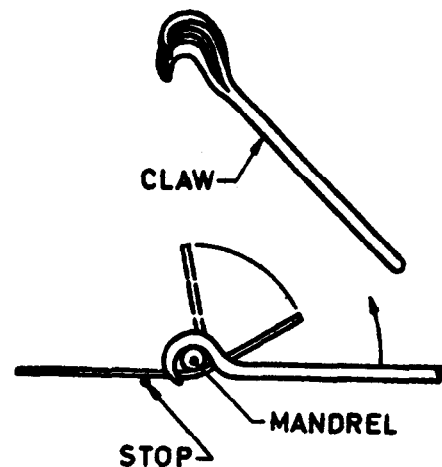

FIG. 13.1 BENDING OF BAR BY MEANS OF CLAW

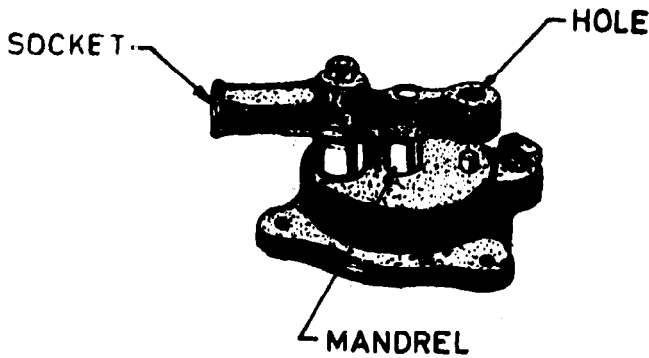

FIG. 13.2 SIMPLE BAR-BENDING MACHINE

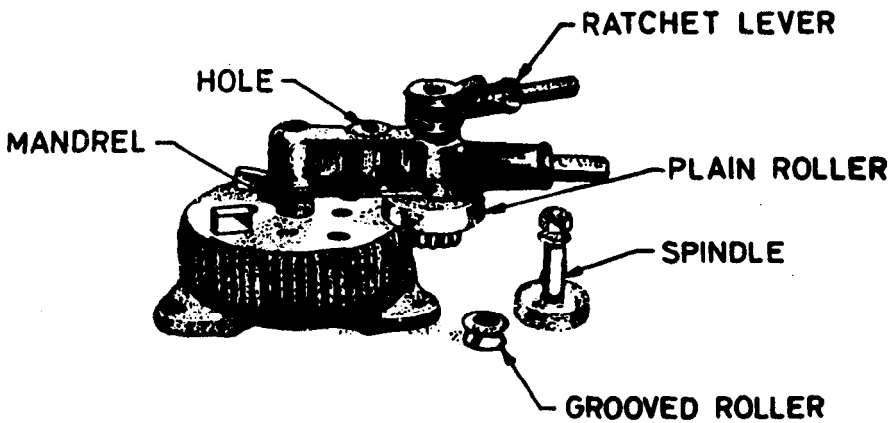

FIG. 13.3 GEARED BAR-BENDING MACHINE

power-operated benders. However, where only a few bars are to be bent, easy bends may be formed by jimcrow or rail bender, an appliance comprising forged bow with a steel square threaded screw.

13.3.2.3 Where large quantities of bars are to be bent, power-operated benders may be advantageously used.

13.3.2.4 *Operation* — The hand-operated benders are generally mounted on tables. Various operations involved and the schematic way of bending are illustrated in Fig. 13.4. The bar to be bent should be placed between two stops driven into a steel or wooden table. The bar should be held rigid at one of the stops by a roller sitting over the mandrel. By using a tommy bar and levering, the bar may be bent to the desired angle.

13.3.2.5 Special patented appliances for bending bars into helical, rectangular and other shapes are available and they may also be used.

13.3.3 *Bending and Cutting Tolerances* — Where an overall or an internal dimension of the bent bar is specified, the tolerance, unless otherwise stated, should be as follows:

| | <i>Dimension</i> | | <i>Tolerance</i> | |
|-------------------|------------------|----|------------------|------|
| | | cm | | mm |
| For bent bars | ≤ 75 | | + 3 | - 5 |
| | $> 75 \leq 150$ | | + 5 | - 10 |
| | $> 150 \leq 250$ | | + 6 | - 15 |
| | > 250 | | + 7 | - 25 |
| For straight bars | All lengths | | + 25 | - 25 |

13.3.3.1 Any excess in length of bar supplied over the total of lengths of the various portions of the bar between bends, including the specified tolerances or not, shall be taken up in the end anchorages, or in that portion of the bar which shall be indicated on the schedule. The cutting lengths shall be specified to the next greater whole 25 mm of the sum of the bending dimensions and allowance.

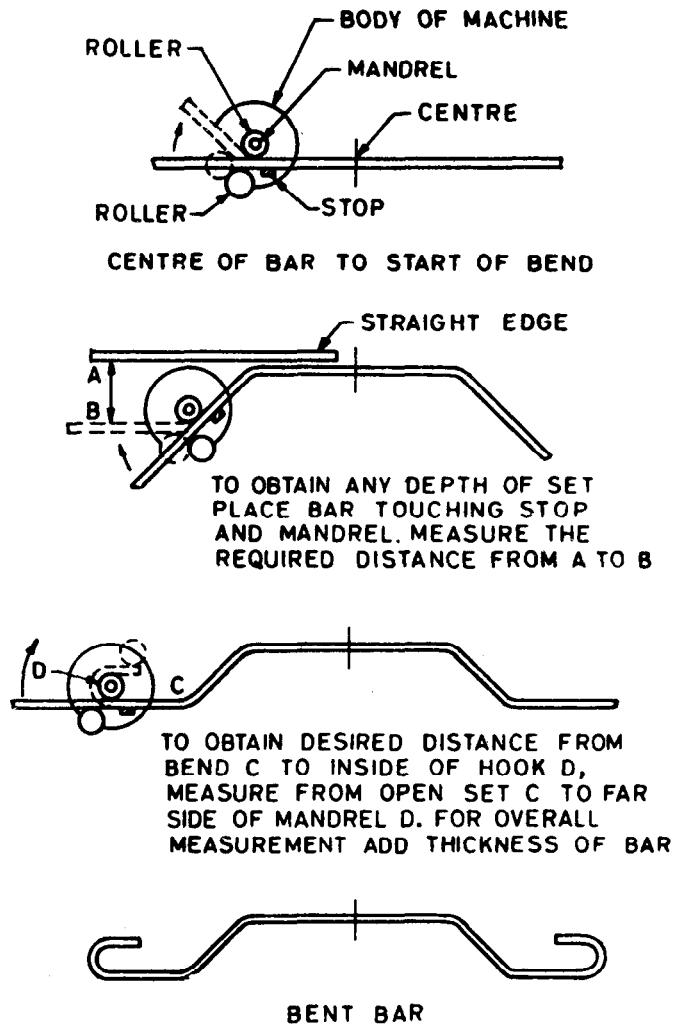

FIG. 13.4 BENDING OF BAR

13.3.3.2 The cutting tolerance for bars to be bent shall be the tolerance given for straight bars. To allow for this cutting tolerance when dimensioning bent bars, at least one dimension shall not be specified.

13.4 Assembly and Placing of the Reinforcement Elements

13.4.1 *General*—This section covers the partial or total (flat or spatial) assembly, in accordance with the reinforcement drawings, of the reinforcement elements. This assembly may be carried out:

- a) at the works,
- b) at the fabrication location on site, and
- c) at the immediate position of the component, that is:
 - 1) in the shuttering,
 - 2) above the shuttering, and
 - 3) outside the shuttering.

If assembly is not carried out at the spot where it is to be positioned, the accuracy of the assembly shall be closely monitored. Depending on the assembly point and subsequent handling, various precautions have to be observed:

- a) conformity to the schedules, respect of tolerances imposed, respect of spacing, cover and lapping of the bars;
- b) invariability of the position of the bars, rigidity of the whole; and
- c) possibility of placing and compacting the concrete (with a vibrating poker in many cases).

These problems shall be taken into account from the design stage onwards.

These conditions can be satisfied by well-thought out design and careful assembly.

For assembly outside the shuttering, the fixer uses gauges, trestles and special temporary wooden supports (or steel in the works). These

devices can sometimes consists of auxiliary reinforcing bars which do not play a part in carrying stresses. The placing of these bars shall conform to the various regulations concerning the concrete cover, distance between bars, etc.

In addition some auxiliary bars are, if necessary, planned to prevent large deformations in the reinforced and assembled structures. Handling of prefabricated reinforcement requires some care: any accidental displacement of a bar or any permanent deformation should be avoided.

In some cases, and in particular for large reinforced structures, hoisting equipment is fitted with a spreader bar hooked in several places to the element to be positioned (see Fig. 13.5). Assembly may involve cases where only partial assembly can be carried out since the weight to be lifted and/or the accessibility of the shuttering and the possibility of making satisfactory joints inside the formwork act as limits.

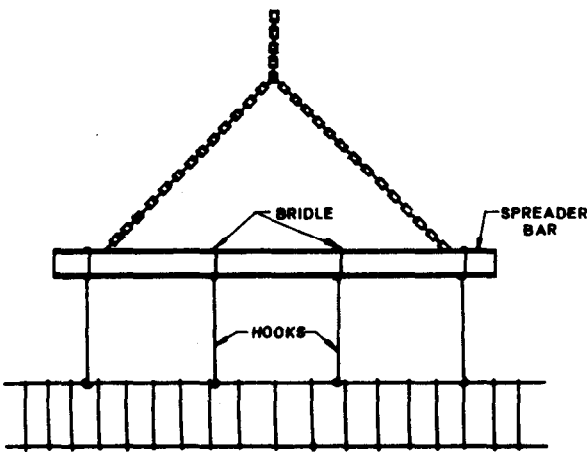

1. Bridle 2. Spreader Bar 3. Hooks

FIG. 13.5 HOISTING EQUIPMENT

The various assembly operations shall take account of the presence of elements such as recesses and service pipes and conduits, etc, embedded in the concrete of the structural element.

Prefabricated reinforcement is fixed with ties, couplers, welds or carefully arranged supports, of suitable solidity and in sufficient number so that they can be neither displaced nor deformed during placing of the concrete or during transport and placing of the reinforcement structure when it is assembled outside the shuttering.

The cost of reinforcement may be broken down as follows:

| | | | |
|------|---|-----------------|-----------------------|
| Cost | { | — raw materials | |
| | | — production | |
| | | — design costs | — calculations |
| | | | — drawings |
| | | | — preparing schedules |
| | | — checking | |

Production costs (cutting, bending, transport, assembly and fixing) may vary depending on the product, preparation, design of the reinforcement, from 4 to 5 manhours per tonne to 150 manhours per tonne.

Examples

Reinforcement of a Beam or Column (Outside the Shuttering).

Cut and bent bars are stored nearby, sorted and collected into bundles and labelled (these have been produced either on site, or delivered cut and bent by a reinforcement factory).

The fixer puts longitudinal bars on chair supports (minimum 2 chairs). The position for stirrups is measured and marked off. Each stirrup by being moved slightly apart is introduced around the bars. Angle bars are tied with a double knot to the main upper bars. By separating slightly either the chair, or the bars, the lower bars are brought down; these are held by the stirrups. The necessary intersections are tied up. In some cases, dowel bars are introduced at the ends of the cage. Removal of the whole after labelling (if not to be used immediately).

Reinforcement of a Slab :

- marking off in chalk the distances between axes;
- placing of the main bars;
- placing of the secondary reinforcement;
- tying of intersections;
- placing of the spacers for the lower bed;
- placing of spacers between two layers;
- placing of the distribution reinforcement on the spacers, and other secondary reinforcement on the lower bed;
- placing of the main reinforcement; and
- lifting of the secondary reinforcement and tying.

Reinforcement of a Wall — In general, the wall remains accessible from at least one side: reinforcement starts on the other:

- fixing of vertical bars to the dowel bars and the spacers;
- positioning and tying of horizontal bars;
- positioning of the horizontal dowel bars for the front bed;
- fixing of vertical bars and tying in horizontal bars lifted as needed; and
- placing of spacers between the two vertical layers.

Assembly of Prefabricated Reinforcement — Apart from the problem of deformability during transport and handling, assembly is carried out in the same way as above, but at the works. Fixing is carried out by welding or tying. Units are limited by the lifting capacity available on site and the maximum dimensions authorised for the means of transport anticipated.

The reinforcement factory decides on the method of jointing reinforcement structures

(independent bars to be drawn from the cages, welding or mechanical coupling methods, etc).

13.4.2 Fixing — As regards assembly on site, bars which touch while crossing are fixed generally by very tight annealed wire ties of 1 to 2 mm, or sometimes by some special device.

13.4.2.1 Tying — Tying may, in order of increasing resistance to slipping, be by means of a:

- single or snap tie (see Fig. 13.6)
- saddle ties
- figure of eight tie

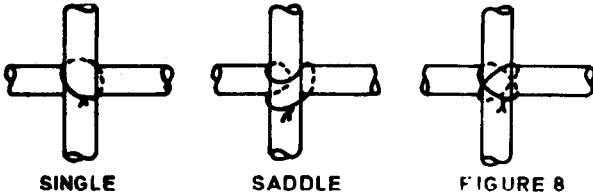

FIG. 13.6

Recourse to stronger ties may enable the number of nodes tied to be limited. It is, in any event, recommended that the direction of single knots be alternated so as to increase the rigidity of the mesh (see Fig. 13.7).

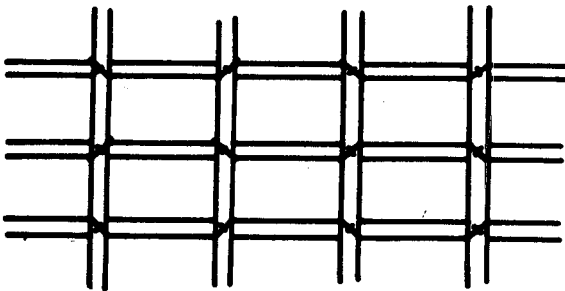

FIG. 13.7 ALTERNATED TYING

The need to tie a certain percentage of the nodes depends not only on the type of tie used, but also on the diameter of the bars, their surface shape (smooth or notched) and the rigidity which one wishes to give to the reinforcement (handling, transport, etc).

Tying wire is delivered in small coils.

Pieces of wire with two eyelets are also used, tied with the aid of special pliers with a hook. This method is faster with an unskilled workforce (see Fig. 13.8).

With skilled fixers tying is the best method of jointing on site.



FIG. 13.8 PREFABRICATED FIXING WIRE

The bottom of the shuttering must be cleared of any wire waste before concreting to prevent it causing rust stains and corrosion paths on the surface from which the shuttering is to be removed. For this purpose a magnet suspended at the end of a chain which is taken along the bottom of the shuttering, or even a jet of compressed air, may be used.

13.4.3 Placing the Reinforcement — Correct placing of reinforcement requires proper maintenance of the distances between bars, and concrete cover, that is, the exact placing of the reinforcement in accordance with the drawings.

This is, in general, achieved by using spacers to ensure that the reinforcement is kept in the position allocated in the design, resisting the actions to which it is subjected during placing. The parts of spacers in contact with the shuttering shall resist corrosion and shall not affect the appearance of the concrete when the shuttering is removed. When the concrete has hardened they shall not cause cracking or infiltration of water, which causes corrosion.

13.4.3.1 Distance between parallel reinforcement elements:

- a) *Between horizontal layers* — The distance between these layers is often ensured by means of a bar (say 12 mm diameter) bent as shown in Fig. 13.9.

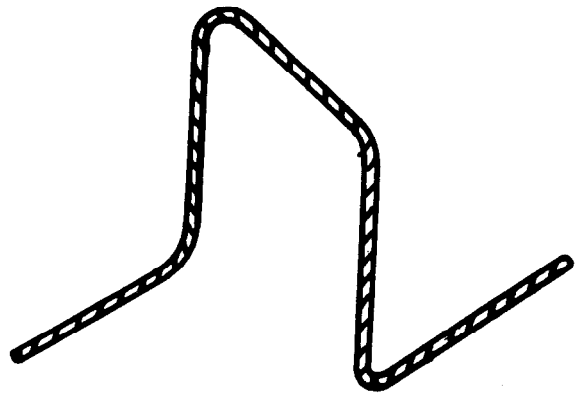
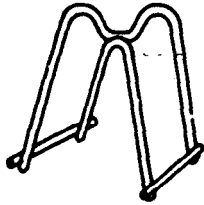
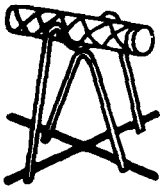

FIG. 13.9 LAYER SPACERS

This high chair, which is easy to make on site, is fixed to the main reinforcement and is never in direct contact with the shuttering.

Prefabricated devices such as those indicated in Fig. 13.10 are also used, either for isolated bars (bar chairs), or for heavy layers (continuous chairs and bolsters).

- b) *Between vertical layers* — The distance between vertical layers of reinforcement (see Fig. 13.11) is usually ensured by means of straight bars, hooked bars or bars bent into a U, tied to the main reinforcement.



13.10A FOR ISOLATED BARS (HIGH CHAIRS)



13.10B FOR HEAVY LAYERS (CONTINUOUS CHAIRS)

FIG. 13.10 CHAIRS

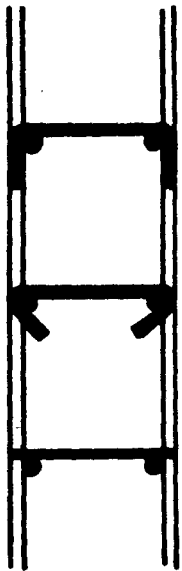

U-BAR

HOOKED BAR

STRAIGHT BAR

FIG. 13.11 SPACERS FOR VERTICAL LAYERS

Fixing by a straight bar can never be correctly ensured.

Hooked bars do not prevent vertical layers from moving closer together, therefore, tying is necessary.

Bars bent into a U may be easily and correctly tied to the main reinforcement and is the best solution.

There are metal devices ensuring simultaneously correct spacing of the vertical bars (fixing by gripping) the cover required and the distance between the walls of the shuttering. Plastic caps are fitted to prevent corrosion of the metal piece on the surface of the concrete (see Fig. 13.12).

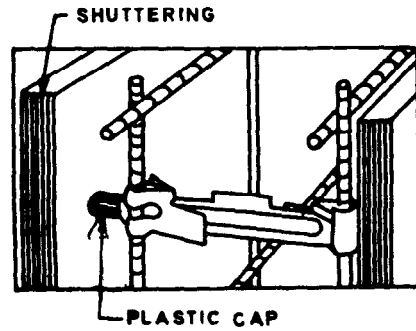

FIG. 13.12 SPACERS FOR REINFORCEMENT AND SHUTTERING

c) *In beams and columns* — In beams, columns and other elements the main bars, which are parallel, are connected by tying to the stirrups in order to form a rigid cage.

13.4.4 Fixing Reinforcement in Relation to the Shuttering — It is essential to maintain the distance between the reinforcement and the shuttering indicated on the drawing.

This is necessary to provide a uniform concrete cover to the reinforcement so as to protect it from corrosion.

13.4.4.1 Horizontal shuttering — In the case of horizontal shuttering, the device used must be able to support the following without risk of piercing the shuttering:

- the weight of the reinforcement;
- supplementary loads resulting from the placing of the concretes;
- supplementary loads due to movement of workers over the reinforcement network.

In foundation pads, the layer of reinforcement is placed on mortar or concrete blocks or on strips of mortar cast in place between two joists. These supports themselves rest either on blinding concrete (general case) or directly on the ground (see Fig. 13.13).

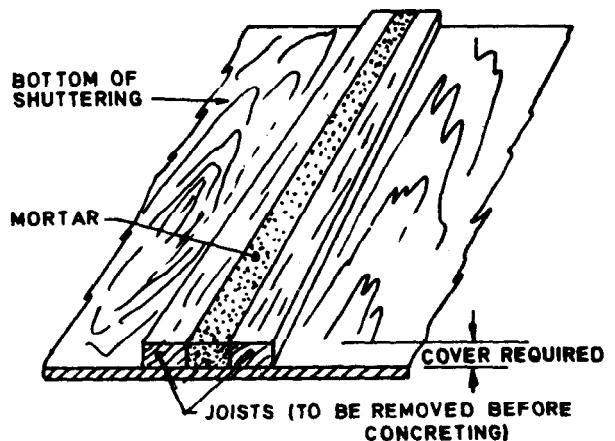

FIG. 13.13 STRIP OF MORTAR CAST ON THE SHUTTERING (OR ON THE GROUND)

The mortar should, of course, have hardened sufficiently before the reinforcement is placed.

The disadvantages attributed to this system arise from the haste in placing reinforcement structures which are often very heavy on mortar which is too fresh and which is then likely to break.

At the bottom of the shuttering, continuous metallic supports are also used, the feet of which are sometimes fitted with plastic caps to prevent rust stains on visible surfaces, or continuous supports entirely in plastic. The latter model presents the disadvantage of not guaranteeing correct filling of the lower part by the concrete (see Fig. 13.14).

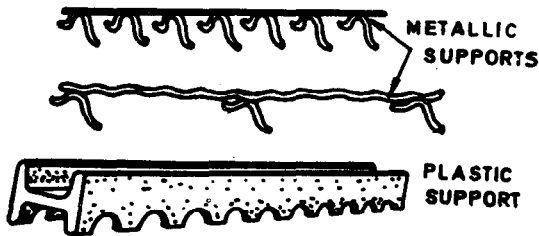

FIG. 13.14 CONTINUOUS SUPPORTS FOR LAYERS OF REINFORCEMENT

For layers of reinforcement for reinforced concrete road surfaces in the USA, bent ribbed sheet-metal supports placed directly on the ground are very widely used.

There is a very wide variety of individual supports which may, for greater ease, be classified according to the constituent material:

- a) *Mortar supports* (see Fig. 13.15)—The blocks of mortar are most often produced on the site. The trend is, however, towards an increasing use of prefabricated pieces, the shape of which is sometimes more suitable and the composition more homogeneous. The blocks often have a tying wire in mild annealed steel or in galvanised steel, or a wire with two eyelets.

The area of contact with the shuttering may be reduced by giving a hemispherical or cylindrical shape to the block. In this case adequate cover of the block is not always ensured if the concrete used is very dry or has undergone little vibration.



FIG. 13.15 TYPES OF MORTAR BLOCK SUPPORT

The blocks or wedges of mortar are visible after the shuttering has been removed if their composition is different from that of the concrete in the structure and if their porosity is likely to cause absorption of the oil used for removal of the shuttering.

Bonding to the concrete is always well assured, and no cracking is noted where the block of mortar is located.

Rings of mortar through which the reinforcement is threaded are relatively fragile; they can break when the reinforcement is put in place in the shuttering.

NOTE—Mortar blocks as spacer blocks should not be permitted on the faces in contact with the liquid in case of reservoirs and tanks.

- b) *Asbestos-cement supports* (Fig. 13.16)—There are different forms, with or without tying wire, which limit the area of contact with the shuttering.

The mechanical strength is at least as good as that of blocks of mortar; they are less fragile and bond well with the concrete.



FIG. 13.16 TYPES OF ASBESTOS-CEMENT SUPPORTS

- c) *Plastic supports*—These are of two types; (see Fig. 13.17).

- a) Supports of the 'chair' type on which the bar is generally simply placed, sometimes gripped. They look like a cradle resting on a cylindrical base or with components which are either parallel or crossed (cruciform contact with the shuttering).

Supports of this type can generally support heavy loads. They do on the other hand have the disadvantage of presenting a large area of contact with the shuttering; some models have cavities, the complete filling of which with concrete may create a problem.

- b) Supports of the 'circular' type which are fixed to the reinforcement by gripping. They are generally weaker and may give way under the weight of heavy reinforcement.

They are certainly more suitable for vertical reinforcement than for horizontal reinforcement. The support must be designed to allow good anchoring in the concrete while not constituting too large a discontinuity in the section passing through its plane.

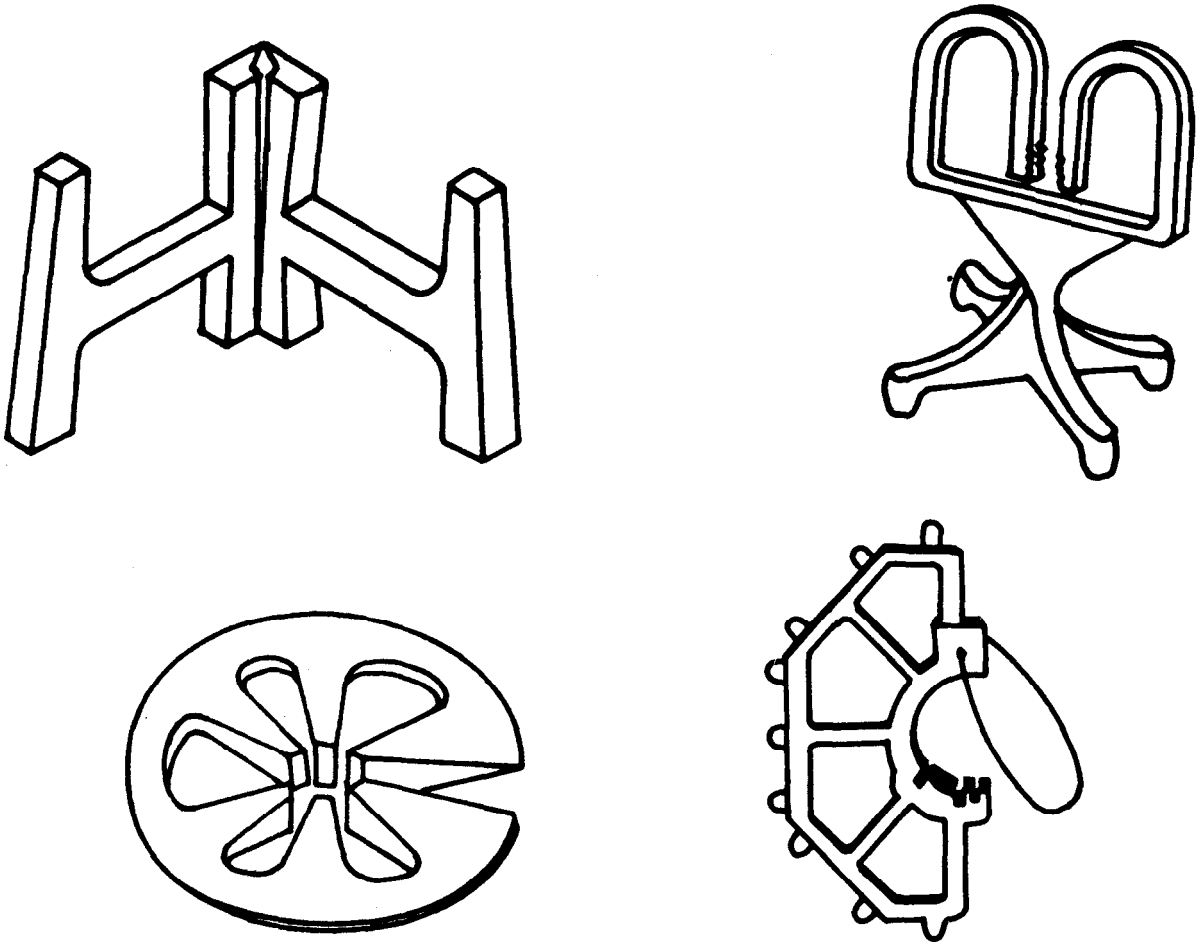

FIG. 13.17 PLASTIC SUPPORTS

Contact with the shuttering is limited to the ends of the spokes or a very limited portion of rim.

13.4.4.2 Vertical shuttering — Here the role of the spacer is basically to maintain the desired distance between the reinforcement and the wall of the shuttering; the spacer does not have to bear large loads.

It must, on the other hand, be correctly fixed to the reinforcement so that it does not move under its own weight (vertical reinforcement), or at the moment of concreting (fall of concrete, vibration, etc).

This fixing is carried out either by binding (mortar or asbestos cement blocks) or by the very elasticity of the material (plastic spacers fixed by gripping). The types listed in 13.4.4.1 may, in general, be suitable on condition that they are fixed correctly to the reinforcement.

In columns, in particular, it is better not to use the circular type spacers on the vertical

reinforcement, since they constitute obstructions when concreting; it is preferable to place them on the horizontal reinforcement.

13.4.4.3 Upper reinforcement in slabs — The upper network of reinforcement in slabs or floors usually rests on the lower network by means of chairs (see Fig. 13.18).

The reinforcement network sometimes rests on the bottom of the shuttering by means of high blocks of mortar or concrete (up to 15 to 20 cm high) which are in the form of a pyramid or a truncated cone.

High metal chairs, individual or continuous, are also used and sometimes fitted with plastic caps.

13.4.5 Factors Determining the Choice of a System — Table 13.1 presents the factors governing the choice of reinforcement supports.

When two figures are given for a single characteristic, each concerns a support variant or

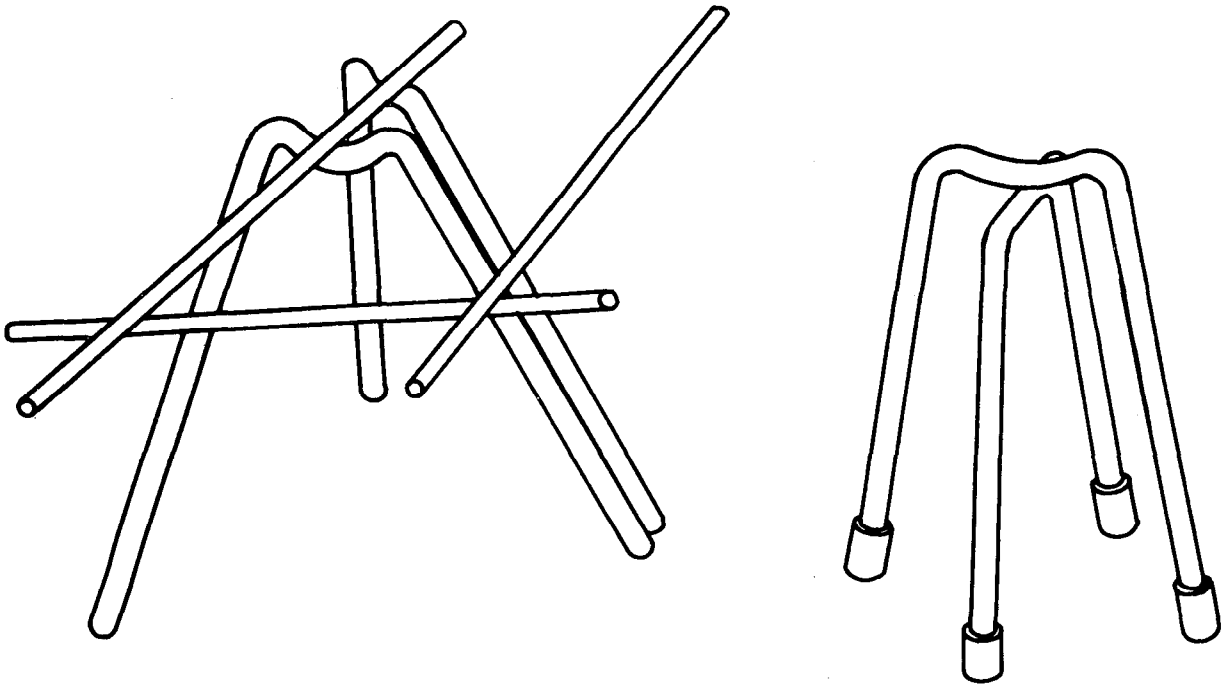

FIG. 13.18 HIGH METALLIC CHAIRS

a different method. It is necessary in this case to refer to the corresponding comments.

It is obvious that some criteria may be essential, for example, fire resistance, and that the use of

the table shall be altered accordingly.

It is advisable to avoid the use of supports, specially mortar supports which are left behind on the inner face of water retaining structures.

TABLE 13.1 THE CHOICE OF A SUPPORT

| FACTORS TO BE CONSIDERED | GRADE OF APPRECIATION | | | | FACTORS TO BE CONSIDERED | GRADE OF APPRECIATION | | | | |
|--|-----------------------|---------|---------|-----------|--|-----------------------|---------|---------|-----------|--|
| | Asbestos | | Plastic | | | Asbestos | | Plastic | | |
| | Mor-tar | Cem-ent | Chair | Cir-cular | | Mor-tar | Cem-ent | Chair | Cir-cular | |
| (1) | (2) | (3) | (4) | (5) | (1) | (2) | (3) | (4) | (5) | |
| <i>Economic factors</i> | | | | | <i>Factors associated with the device placed in the concrete</i> | | | | | |
| Purchase price | 1 | 2 | 2 | 2 | Thermal treatment of the concrete | 1 | 1 | 3 | 3 | |
| Ease of storage and handling | 3 | 2 | 1 | 1 | Facing concrete (immediately after removal of shuttering) | 2-3 | 2 | 4 | 3 | |
| Speed and ease of placing | 1-3 | 1-3 | 1 | 2 | Treatment of the concrete surface | 2 | 2 | 4 | 3 | |
| <i>Technical factors associated with the device itself</i> | | | | | Bond with the concrete | 1-2 | 2 | 3 | 3 | |
| Crushing strength | 1-2 | 1 | 2 | 3 | Corrosion of the reinforcement | 2 | 2 | 3 | 3 | |
| Strain under load | 1 | 1 | 1 | 3 | Fire resistance | 1 | 1 | 4 | 4 | |
| Uniformity of dimensions | 2-3 | 1 | 1 | 2 | | | | | | |
| Use in cold weather | 1 | 1 | 2 | 3-4 | | | | | | |
| Scratching, scoring or piercing of the shuttering | 3 | 3 | 2 | 2 | | | | | | |

1 = excellent; 2 = good; 3 = admissible; 4 = not recommended.

SECTION 14
Typical Structural Drawings

SECTION 14

TYPICAL STRUCTURAL DRAWINGS

14.1 Some examples of structural drawings (*see* pages 243-280) giving details of structural elements—footings, columns, beams, slabs, etc., are included. These are included for the purpose of illustration only; they are not intended as recommendations for design although they generally meet the requirements of IS : 456-1978. These drawings are intended to emphasize how design information is represented on structural engineering drawings. Specific locations of cut off points, bends, amounts of steel, etc., are shown as examples to convey necessary information through the drawings. These are not to be considered as standard methods of detailing for a specific structure.

The above drawings are based on the drawings

of different projects from different organisations* and each one gives only a part of the information relating to each structure/project. These drawings have been modified, wherever necessary, more or less to suit the requirements of the Handbook. Details of minor nature (as were relevant to the situation) have also been deleted for the purpose of this Handbook.

*BIS acknowledges with thanks the following organizations who were helpful in providing the basic drawings on the basis of which the present drawings have been included:

1. National Industrial Development Corporation Limited, New Delhi;
2. Engineering Consultants (India), New Delhi;
3. Central Public Works Department (CDO), New Delhi; and
4. Bharat Heavy Electricals Limited, New Delhi.

APPENDIX A

(Clause 4.4)

WELDING

A-0 GENERAL — Welded joints are permitted in reinforcement (mild steel and deformed bars) subject to the condition that in all cases of important connections, tests shall be done to prove that the joints are of the full strength of bars connected.

A-1 WELDING OF MILD STEEL PLAIN AND HOT ROLLED DEFORMED BARS

A-1.0 The requirements for welding mild steel round and deformed bars conforming to mild steel, Grade I, conforming to IS : 432(Part 1)-1982 'Specification for mild steel and medium tensile steel bars and hard-drawn steel wire for concrete reinforcement: Part I Mild steel and medium tensile steel bars (*third revision*)' and hot rolled deformed bars conforming to IS : 1786-1985 'Specification for high strength deformed steel bars and wires for concrete reinforcement (*third revision*)' are given in IS : 2751-1979 'Code of practice for welding of mild steel plain and deformed bars for reinforced concrete construction (*first revision*)'.

NOTE 1 — Hot rolled deformed bars/wires conforming to IS : 1786-1985 will have their transverse and longitudinal ribs in straight lengths.

NOTE 2 — For guaranteed weldability, the percentage of carbon shall be restricted to 0.25 percent, maximum.

A-1.1 Electrodes and Filler Rods

A-1.1.1 Electrodes — Covered electrodes for manual metal arc welding shall conform to IS : 814 (Part 1)-1974 'Specification for covered electrodes for metal arc welding of structural steel: Part 1 For welding products other than sheets (*fourth revision*)' and IS : 814 (Part 2)-1974 'Specification for covered electrodes for metal arc welding of structural steel: Part 2 For welding sheets (*fourth revision*)'.

A-1.1.2 Filler Rods — Mild steel filler rods for oxy-acetylene welding shall conform to type S-FS7 of IS : 1278-1972 'Specification for filler rods and wires for gas welding (*second revision*)' provided they are capable of giving a minimum butt weld tensile strength of 410 MPa.

A-1.1.3 Mixtures for thermit welding shall be capable of yielding weld metal of the required composition and the tensile strength shall be at least 410 MPa.

A-1.2 Flash Butt Welding — Electric flash butt welding may be adopted if a number of welds have to be done at the same place and when the electric supply is available of the required capacity in respect of the cross-sectional area of the maximum size of bar to be welded.

A-1.2.1 Preparation for Welding — The ends of the bars to be welded shall be sheared off so that fresh steel surfaces are available for welding. The surfaces of the ends of the bars to be clamped shall be cleaned free from rust to enable free flow of electricity in the bars.

A-1.2.2 Procedure — The procedure for flash butt welding shall generally be in accordance with the 'Indian Standard Recommended Procedure for Flash Butt Welding' (*under print*).

A-1.2.2.1 The ends of the bars to be welded are placed in proper alignment in the clamps so that bend or eccentric joints do not result. The clamps should be cleaned before each welding operation to avoid current losses and also to eliminate harmful notches or grooves due to burning in of spots of arcing.

A-1.2.2.2 Welding should be done without any preheating of bars. The bar ends shall be uniformly pushed against each other from the moment of contact up to the upsetting. The transformer regulator should be so set that the current at the contact area is between 85 and 90 A/mm².

A-1.2.2.3 If the butt welding machine or the available power is not sufficient to take the load for welding the bar in the cold condition, welding may be done after preheating. By repeated making and breaking of the contact arc, heat can be made to spread over the entire cross-section of the bar. The number of short circuits (contacts and reversing) should be kept to the minimum possible so that the welding time and spread of heat in the longitudinal directions in the bar is minimum. Satisfactory joints with only slight reduction in the original strength of the bar can be achieved with current densities up to 25 A/mm².

A-1.2.2.4 In automatic machines, the flash rate should be so set that a continuous flash without interruption can be achieved. If too high a rate is set, then additional short circuits are required leading to a heat spreading. If the rate is too low, the flash will be interrupted, consequently air penetrating into the joint will form oxides. If the machine is hand operated, the flash should be maintained to avoid interruption.

A-1.2.2.5 Burn-off length — For bars with sheared ends a burn-off (flash-off) length of about 10 mm is required, this length being practically independent of the bar diameter. Very short burn-off length leads to defective welding because all the impurities will not have been removed from the place of welding. Increase in the burn-off

length of the bar thus reducing the strength of the bar.

A-1.2.2.6 Upsetting — The upsetting should result from the burning off, that is, without interruption in the rain of sparks. The electric supply should be switched off about 1/3 to 1 second after the start of the upsetting or in the case of automatic machine, after 1 to 3 minutes of upset travel.

The voltage and frequency of the current should be checked before commencing the welding operation. Such deviations from the nominal value or large fluctuations during the operation may lead to gross defects in the welding. Wherever possible, welding should be done in periods of the day when the total load on the network is fairly balanced.

A-1.3 Fusion Welding of Mild Steel Bars — Steel bars shall be either butt welded or lap

welded using any of the following fusion welding processes:

- a) Manual metal-arc welding,
- b) Oxy-acetylene welding,
- c) Gas pressure welding, and
- d) Thermit welding.

Thermit welding shall be generally in accordance with the 'Recommended practice for fusion welding of ferrous metal by aluminothermic process' (*under print*).

A-1.3.1 Butt Welding of Mild Steel Bars — Bars may be spliced by butt welding them directly or through a splice number such as angle, sleeve, bars, etc.

A-1.3.1.1 The preparation of edges for different types of butt welds shall be in accordance with Table A-1.

TABLE A-1 EDGE PREPARATION FOR MANUAL METAL ARC WELDING
(Clause A-1.3.1.1)

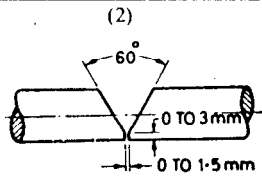
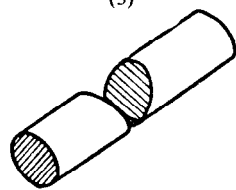
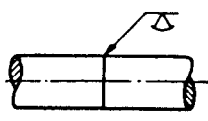
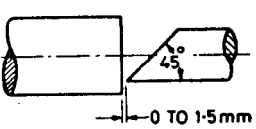
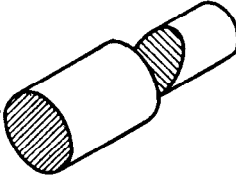
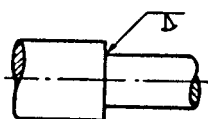
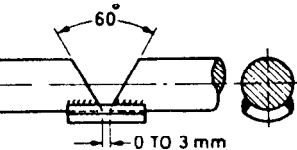
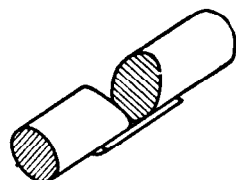
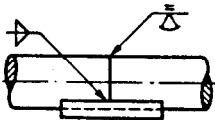
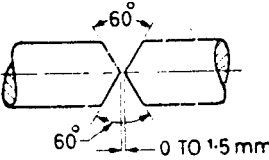
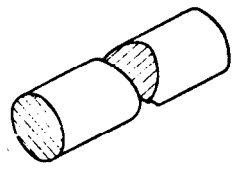
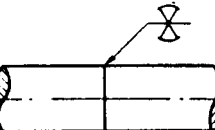
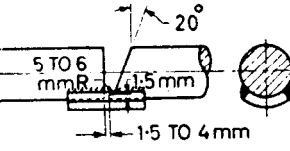
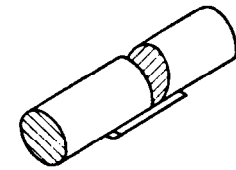
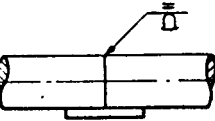
| Sl. No. | DETAIL | TYPE OF JOINT | SYMBOLIC REPRESENTATION | SIZE RANGE | APPLICATION |
|---------|---|---|--|---|--|
| 1 | (2)  | (3)  | (4)  | (5) 20 to 25mm | (6) Where the root is accessible for back-chipping and application of a sealing run. |
| 2 |  |  |  | Smaller bar 20 to 25mm welded to larger bar | Where the root is accessible for back-chipping and application of a sealing run. |
| 3 |  |  |  | 20 to 50mm | Where access to the root of the weld is unobtainable. Alternatively a removable copper backing bar may be used in place of the integral steel backing shown. |
| 4 |  |  |  | 25 to 50mm | For general use; Horizontal bars should be turned for flat position welding, wherever possible. |
| 5 |  |  |  | 40 to 50mm | Where access to the root of the weld is unobtainable. |

(Continued)

TABLE A-1 EDGE PREPARATION FOR MANUAL METAL ARC WELDING (Contd.)

(Clause A-3.1.1.1)

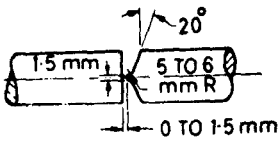
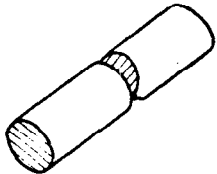
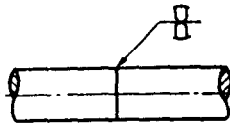
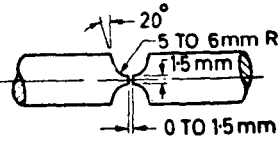
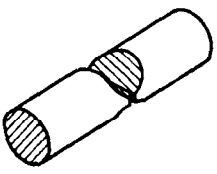
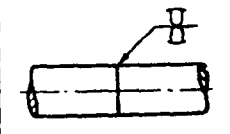
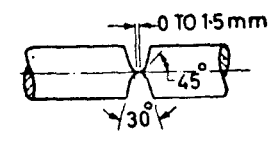
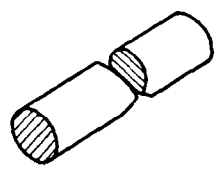
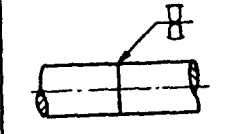
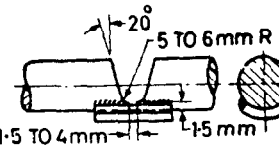
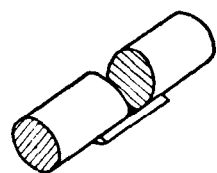
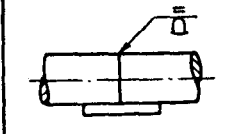
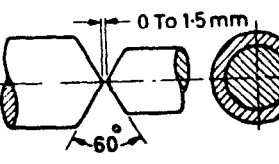
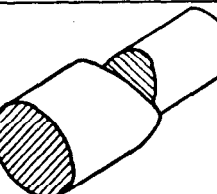
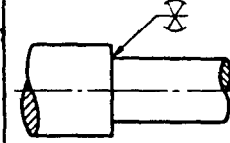
| Sl. No. | DETAIL | TYPE OF JOINT | SYMBOLIC REPRESENTATION | SIZE RANGE | APPLICATION |
|----------|--|--|--|--|--|
| (1) 6 | (2)  | (3)  | (4)  | (5) 40 to 50mm | (6) For general use: Horizontal bars should be turned for flat position welding, wherever possible. |
| 7 |  |  |  | 40 to 50mm | Where access to the root of the weld is unobtainable. |
| 8 |  |  |  | 40 to 50mm | Where the increased difficulty of preparation will be offset by the reduction in welding cost. |
| 9 |  |  |  | 40 to 50mm | Where access to the root of the weld is unobtainable. |
| 10 |  |  |  | Smaller bar over 25mm welded to larger bar | For general use: Horizontal bars should be turned for flat position wherever possible. |

A-1.3.1.2 The edges shall be prepared by shearing, machining or oxy-acetylene flame cutting. Bevelling may be done by chipping, machining grinding or oxygen cutting. The joint faces and the surrounding portion of the bars shall be free from scale, dirt, grease, paint, rust and contaminants.

A-1.3.1.3 When it is not possible to rotate the bars for welding in flat position, the axis of the bars shall be horizontal and the respective axes of welds shall be vertical, that is, welds being carried out in the vertical position.

A-1.3.1.4 In the case of inclined bars, the edge preparation shall be such that welding is done only on sides (see Fig. A-1).

A-1.3.1.5 All the bars to be welded should be aligned and set up in position with their axes in one straight line. The joints may not be out of alignment by more than 25 percent of the thickness of the thinner material for material up to and including 12 mm thick, or by more than 3 mm for thicker material. Alignment may be accomplished in a jig, or by means of a clamp or by using guides. Rotation of the bars should be avoided until they are adequately welded, so that no disturbance to the alignment is caused and no twist is introduced in the bars during the process of welding.

A-1.3.1.6 In the case of details 4, 6, 7, 8 and 10 of Table A-1, back chipping in the root is

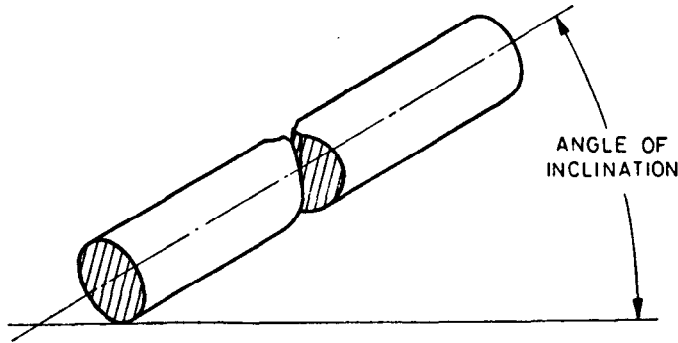

FIG. A-1 EDGE PREPARATION OF INCLINED BARS

recommended before welding is commenced on second side. The root run and one further run should be deposited on the first side. Where possible the back chipping and root run on the second side should then follow and the remaining runs should preferably be deposited on alternate sides of the joint to assist in controlling distortion.

A-1.3.1.7 Indirect butt splices may be made by welding bars to splice plate, angle, sleeve, etc. using single or double fillet welds as shown in Fig. A-2. The splice member used, that is, plate, angle, bar, sleeve, etc. should have a cross-sectional area such that its strength is at least 5 percent higher than the strength of the bars being welded. The bars shall not be eccentric by more than 3 percent of the bars joined. The angles when used may be flattened to suit for welding higher size bars.

A-1.3.2 Lap Welding of Mild Steel Bars

A-1.3.2.1 Edge preparation is not necessary for lap welds. The length of bars to be welded should be free from scale, dirt, grease, paint, rust and contaminants.

A-1.3.2.2 The bars may be lap welded using the details given in Fig. A-3. Detail given in Fig. A-3(A) is used when the bars are in contact with each others. If the bars are bent, the maximum gap shall be 6 mm.

When the gap between bars is more than 6 mm the joint should be made using a splice bar or plate [see Fig. A-3 (A)]. The gap between the bar and splice plate should not exceed 0.25 times the diameter of the bar or 5 mm, whichever is less. The area of the splice material shall be at least 5 percent more than the area of the higher size bar being welded.

Some information regarding throat thickness and reinforcement is given in Table A-2.

A-1.3.2.3 The dimensions of the fillet welds (length and throat thickness) shall be capable of developing the full strength of the bar. The

TABLE A-2 DETAILS FOR LAP WELDED JOINTS
(Clause A-1.3.2.2)

| BAR DIAMETER | THROAT THICKNESS | GAP BETWEEN REINFORCEMENT (APPROX) |
|------------------|------------------|------------------------------------|
| (1) | Min | (3) |
| mm | mm | mm |
| Up to 12 | 3 | 1.5 |
| Over 12 up to 16 | 3 | 3 |
| Over 16 | 5 | 3 |

NOTE 1 - If any overhead weld is required, it should be made prior to the flat welds.

NOTE 2 - If the bars are bent, the maximum gap should not exceed 6 mm.

eccentricity in the joint should be taken into consideration in the design calculations.

A-1.3.3 Square Butt Welds— Square butt welds may be used for direct butt welding and shall be made using hydrogen controlled electrodes or the thermit welding process.

A-1.4 Selection of Welded Joints

A-1.4.1 Direct butt splices (Table A-1) and, as a second choice indirect butt splices (see Fig. A-1), should be specified for bars of diameter 20 mm and over in order to reduce effects of eccentricity.

A-1.4.2 For bars of diameter up to 20 mm indirect splicing (see Fig. A-1) may be used although lap welds are normally adopted for such bars.

A-1.4.3 Square Butt Welds— The bars may be directly jointed with square butt welds provided the welds are made using hydrogen controlled electrodes or thermit welding process.

A-1.5 Location of Welded Joints— Welded joints should be staggered in the length of the

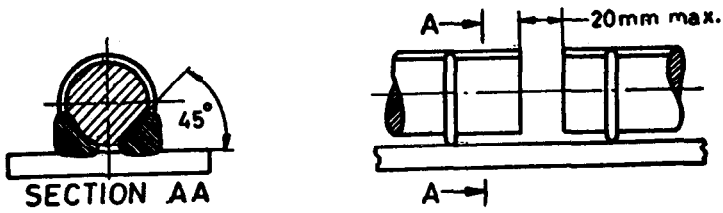

A-2A INDIRECT BUTT SPLICE USING A PLATE

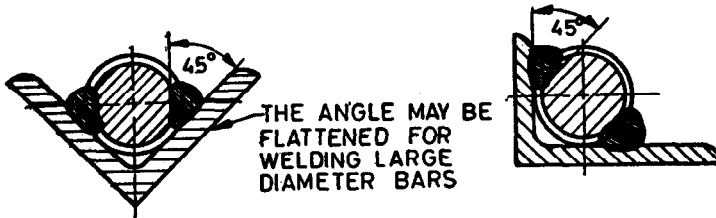

A-2B INDIRECT BUTT SPLICE USING AN ANGLE

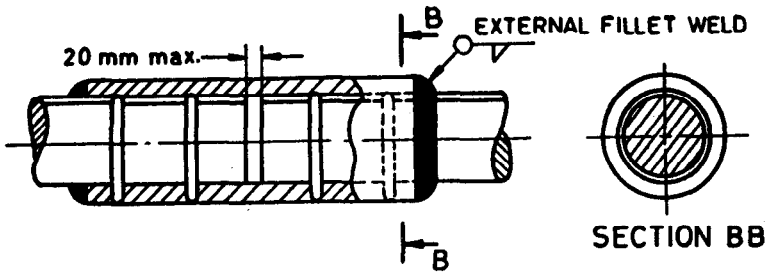

A-2C INDIRECT BUTT SPLICE USING A SLEEVE

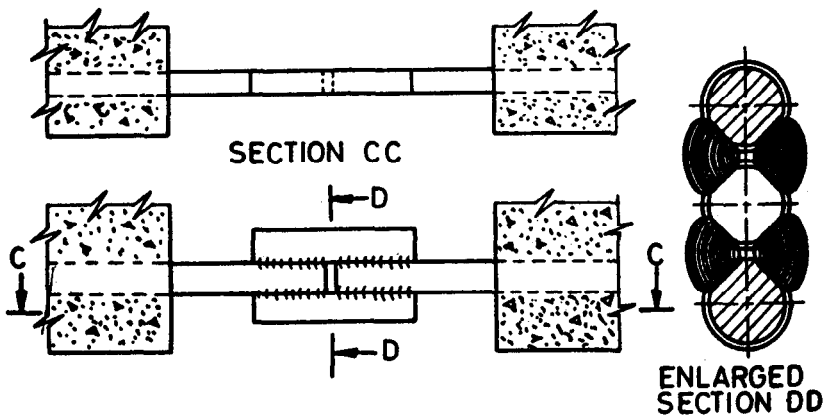

A-2D INDIRECT BUTT SPLICE USING TWO BARS

FIG. A-2 INDIRECT BUTT SPLICES

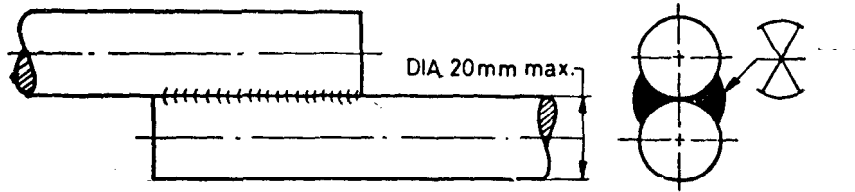

A-3A LAP WELDING BARS IN CONTACT

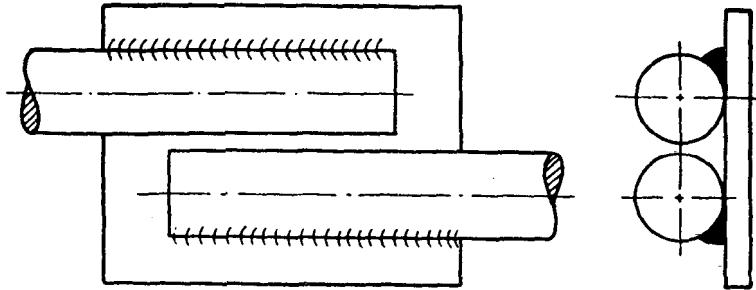

A-3B LAP WELDING BARS WITH BARS SEPARATED BY A DISTANCE

FIG A-3 LAP WELDING OF MILD STEEL BARS

reinforced concrete components. The joints should also not be positioned in highly stressed areas.

A-1.6 Quality Control Tests

A-1.6.1 Butt Welds — Test pieces containing butt welds at the centre in the 'as welded' condition shall be selected at the rate of one for tensile test and one for nick break test for every 500 joints.

A-1.6.1.1 Tensile test — The selected pieces, when subjected to a tensile test, shall have a tensile strength not less than 410 MPa (42 kgf/mm²).

A-1.6.1.2 Nick break test — The test specimen shall be notched as given in Fig. A-4 and shall be broken open along the weld, the fractured surface visually examined for fusion, root penetration, gas cavities and quality of weld metal. The surface should be reasonably free from cavities, inclusions, etc. There shall be no lack of fusion. Small porosity may, however, be permitted.

A-1.6.1.3 Bend test — The specimen shall be bent using any suitable jig. The weld joint should be capable of being bent to an angle of 60° around a mandrel of diameter equal to diameter of bar before any crack appears.

A-1.6.2 Lap Joints — Test pieces containing lap joints at their centre shall be selected at the rate of 1 per 500 joints.

A-1.6.2.1 Tensile test — The load required to shear the joint shall be at least equal to the tensile load required to fracture the bar.

NOTE — When pulling lap weld specimens to determine the tensile strength a jig should be used to prevent distortion due to secondary stresses. The jig may be of design and detail preferred by the testing agency but should prevent change in geometry of the specimen as it is being pulled.

A-1.7 Retests — If a sample selected for testing fails to meet the requirements given under A-1.6.1 or A-1.6.2, the purchaser or his representative shall select two further samples from the same lot. If on testing, either of the samples fails to meet the specified requirements, the whole lot shall be rejected.

A-1.8 Inspection — For purpose of inspection reference shall be made to IS : 822-1970 'Code of procedure for inspection of welds'.

A-1.8.1 The weld size, length and location shall be as stipulated in the drawings, and the metal designated shall be free from cracks, excessive slag inclusions and excessive porosity.

A-1.8.2 The weld metal shall be properly fused with the parent metal without overlapping at the toes of the weld.

A-1.8.3 There shall be no cracks in the heat affected zones of the reinforcing bars or splice members

A-1.8.4 There shall be no serious undercuts in joint subjected to tension.

A-1.8.5 All craters shall be filled to the cross-section of the welds.

A-1.8.6 The visible surfaces of all welds shall be free from entrapped slag and shall be regular and of consistently uniform contour.

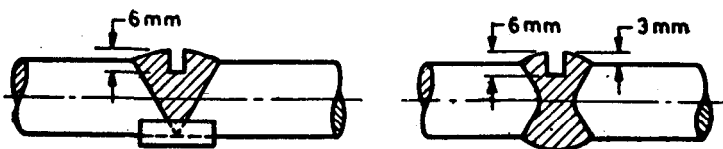

FIG. A-4 NICK BREAK TEST SPECIMENS.

A-1.8.7 All direct butt welds shall be of full cross-section with maximum reinforcement of 3 mm and shall blend smoothly into the face of bars.

A-1.8.8 The profile of fillet welds shall be substantially flat or slightly convex.

A-2 WELDING OF COLD-WORKED STEEL BARS

A-2.0 The recommendation for welding cold-worked steel bars conforming to IS : 1786-1985 is given in IS : 9417-1979.

NOTE 1— Cold-work deformed bars conforming to IS : 1786-1985 will have their longitudinal and transverse ribs twisted and not in straight lines.

NOTE 2— For guaranteed weldability, the percentage of carbon shall be restricted to 0.25 percent, maximum.

A-2.1 Electrodes— Electrodes used shall conform to IS : 814(Part 1)-1974 and IS : 814(Part 2)-1974.

A-2.2 Procedure— Cold-worked steel bars shall be either butt-welded or lap-welded. Butt-welding may be carried out either by resistance butt or flash butt or by manual metal arc welding process.

A.2.2.1 Resistance Butt Welding and Flash Butt Welding of Cold-Worked Bars— Flash or resistance butt welding may be adopted if a large number of welding has to be done at the same place and when the electric supply is available of the required capacity in respect of the cross-sectional area of the maximum size of bar to be welded.

A-2.2.1.1 Preparation for welding— The ends of the bars and the extreme untwisted ends of new bar shall be sheared off so that fresh steel surfaces are available for welding. The surfaces of the ends of the bars to be clamped shall be cleaned free from rust to enable free flow of current in the bars.

A-2.2.1.2 Procedure— The ends of the bars to be welded are placed in proper alignment in the clamps so that bent or eccentric joints do not result. The clamps should be cleaned before each welding operation to avoid current loss and to eliminate harmful notches or grooves due to burning in of spots of arcing.

The bar ends shall be uniformly pushed against each other from the moment of contact up to the upsetting. The transformer regulator should be

so set that the current at the contact area is between 85 and 90 A/mm².

If the capacity of butt welding machine or the available power is not sufficient to take the load for welding from cold, welding may be done after preheating. By making and breaking of the contact arc repeatedly, heat can be made to spread over the entire cross-sections of the bars. The number of short-circuits (contacts and reversing) should be kept to the minimum possible so that the welding time and spread of heat in the longitudinal direction in the bar is minimum. Satisfactory joints with only slight reduction in the original strength of the bar can be achieved with a current densities up to 25 A/mm².

In automatic machines the flash rate should be so set that a continuous flash without interruption can be achieved. If too high a rate is set, then additional short-circuits are required leading to a heat spreading. If the rate is too low, the flash will be interrupted, consequently air penetrating into the joint will form oxides. If the machine is hand-operated, the flash should be maintained to avoid interruption. Too long flashes lead to generation of large quantities of heat thus removing the effect of cold-working in the bar.

Burn-off length— For bars with sheared ends, a burn-off (flash-off) length of about 5 to 7 mm is required, this length being practically independent of the bar diameter. Very short burn-off lengths lead to defective welding because all the impurities will not have been removed from the place of welding. Increase in the burn-off length will spread heat along the length of the bar thus reducing the strength of the bar.

Upsetting— The upsetting should result from the burning off, that is, without interruption in the rain of sparks. The electric supply should be switched off about 1/3 to 1 second after the start of the upsetting or in the case of automatic machine after 1 to 3 mm of upset travel.

The voltage and frequency of the current should be checked before commencing the welding operation. Such deviations from the nominal value or large fluctuations during the welding. Wherever possible, welding should be done in periods of the day when the total load on the network is fairly balanced.

A-2.2.2 Butt-Welding by Metal-Arc Welding Process— Butt-welds are normally adopted to

join bars of thickness more than 20 mm. Welding electrodes with flux covering of Type 3 or 6 (see IS : 815-1974 'Classification and coding of covered electrodes for metal arc welding of structural steel (second revision)') are recommended for better results depending on the size of bar to be welded.

A-2.2.2.1 Preparation for welding

The preparation of the edges of the rods shall be as shown in Fig. A-5. The edges shall be prepared by shearing, machining or oxy-acetylene flame cutting. Beveling may be made by machining, grinding or oxy-acetylene cutting. The fusion faces and the surrounding material shall be free from scale, dirt, grease, paint, rust and contaminants.

When it is not possible to rotate the bars for welding in flat position, the axis of the bars shall be horizontal and the respective welding shall be vertical, that is, the welds being carried out in the vertical position.

In the case of non-rotatable inclined bars, the edge preparation shall be such that welding is done only on sides (see Fig. A-5).

All the bars to be butt welded should be aligned and set up in position with their axis in one straight line. This may be done in a jig or by means of a clamp or by using guides. Rotation of the bars should be avoided until they are adequately welded, so that no disturbance to the alignment is caused and no twist is introduced in the bars during the process of welding. The joints

may not be out of alignment by more than 25 percent of the thickness of the thinner material up to and including 12 mm thick, or by more than 3 mm or thicker material.

A-2.2.2.2 Electrodes — The electrodes shall be so selected that relatively short beads can be rapidly made, since with each bead only a small quantity of heat is transferred to the steel which the steel can conduct away without any harmful effects on the material. If the electrodes move out slowly, a concentration of heat takes place thus removing the effects of cold-working on the bar.

The size of electrode depends upon the length of the bead and thickness of the bar to be welded. The root runs should be made with electrodes of size 3.15 mm. With the number of beads the size of electrode should be gradually increased from 3.15 to a maximum size of 5 mm for the top bead.

A-2.2.2.3 Welding procedure and technique — The sequence of welding beads is shown in Fig. A-6 for information. The runs 1 to 4 are made in the position of welding best suited for the quality of the weld. Besides the interruption in welding required for cleaning of each bead, a pause shall be made after every second bead and the bar is allowed to cool down. The temperature of the bars at a distance of about 20 mm from the joint shall not exceed 300°C immediately after the bead is made. Before commencing the next bead, the temperature shall not exceed 250°C. The temperatures can be checked approximately using temperature indicating crayons.

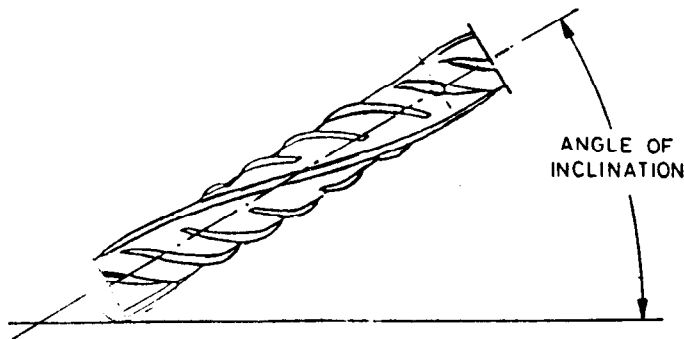

FIG. A-5 EDGE PREPARATION OF INCLINED BARS

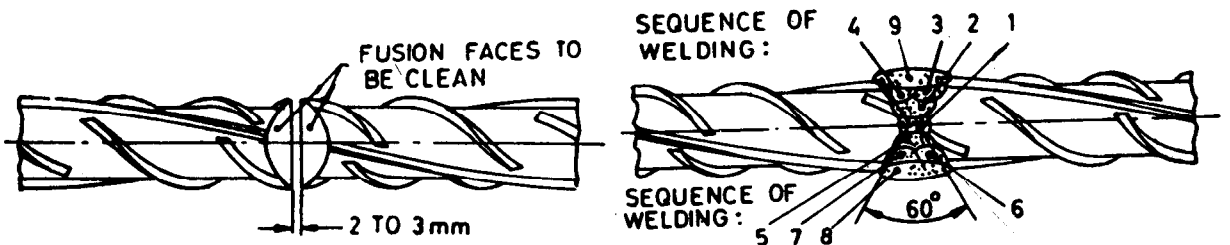

FIG. A-6 SEQUENCE OF WELDING BEADS

After completing the bead 4, the bars are rotated by 180° about their axes, and the beads 5 to 8 are made in a manner described above. The final bead 9 is made in the case of horizontal and freely rotatable bars by weaving in the direction of the bar periphery, the bars being continuously rotated during welding.

In the case of vertical, inclined and non-rotatable bars the beads 1 to 4 shall be made as explained in this clause. The top bead is made by making separate annular runs (see Fig. A-7), the electrode being drawn up to the edge of the top bead. The starting and withdrawal position of the electrodes are shown in Fig. A-7. The top beads are made by drawing the adjacent beads in the longitudinal direction of the bar. The diameter measured over the top of the butt welded joint shall be equal to at least 1.2 times the diameter of the bar.

A-2.2.3 Lap Welding of Cold-Worked Bars — Lap joints may be made in bars of all sizes and qualities of cold-worked bars. They are preferred when access for welding is from only one side and while connecting prefabricated units. Use of electrodes with flux covering of type 3 or 6 are recommended for better results depending on the size of bar being welded.

A-2.2.3.1 Edge preparation is not necessary for lap welds. The joint faces and the surrounding material shall be free from scale, dirt, grease, paint, rust and contaminants.

A-2.2.3.2 Electrodes — The size of electrodes according to the diameter of the bar to be welded shall be as follows:

| Size of Bar mm | Size of Electrode, Min mm |
|--------------------------------|------------------------------|
| Up to and including 6 | 1.6 |
| Over 6 up to and including 10 | 2.0 |
| Over 10 up to and including 14 | 2.5 |
| Over 14 up to and including 20 | 3.15 |
| Over 20 | 4 |

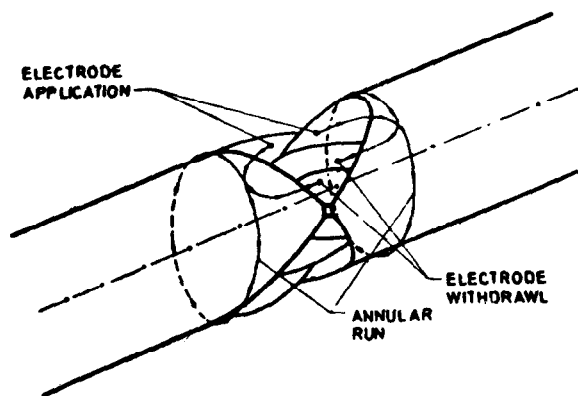

FIG. A-7 MAKING OF TOP BEAD

A-2.2.3.3 Procedure — The arc should be struck as shown in Fig. A-8 somewhere in the middle of the joint and not at its beginning.

The movement of the electrode for welding lap joints in the horizontal and vertical position is indicated in Fig. A-8.

In Fig. A-9 to A-12 are given the various lap joints used to connect cold-worked bars.

A-2.3 Quality Control Tests

A-2.3.1 Butt Welds — Test pieces containing butt welds at the centre in the as welding condition shall be selected at the rate of one for tensile test and one for bend test for every 500 joints.

A-2.3.1.1 Tensile test — The selected pieces, when subjected to a tensile test, shall have a tensile strength not less than 90 percent of the actual tensile strength of the bar but in no case less than the tensile strength of the bar specified in IS : 1786-1985. The fracture shall take place away from the weld.

A-2.3.1.2 Bend test — The welded joint should be capable of being bent to an angle of 60° around a mandrel of diameter equal to diameter of bar before any crack appears.

A-2.3.2 Lap Joints — The pieces containing lap joints at their centre shall be selected at the rate of one in 500 joints.

A-2.3.2.1 Tensile test — The load required to shear the lap joint shall be at least equal to the tensile load required to fracture the bar.

A-2.4 Retests — If a sample selected for testing fails to meet the requirements given under A-2.3.1 and A-2.3.2, the purchaser or his representative shall take two further samples from the same lot. If on testing either of the samples fails to meet the specified requirements, the whole lot shall be rejected.

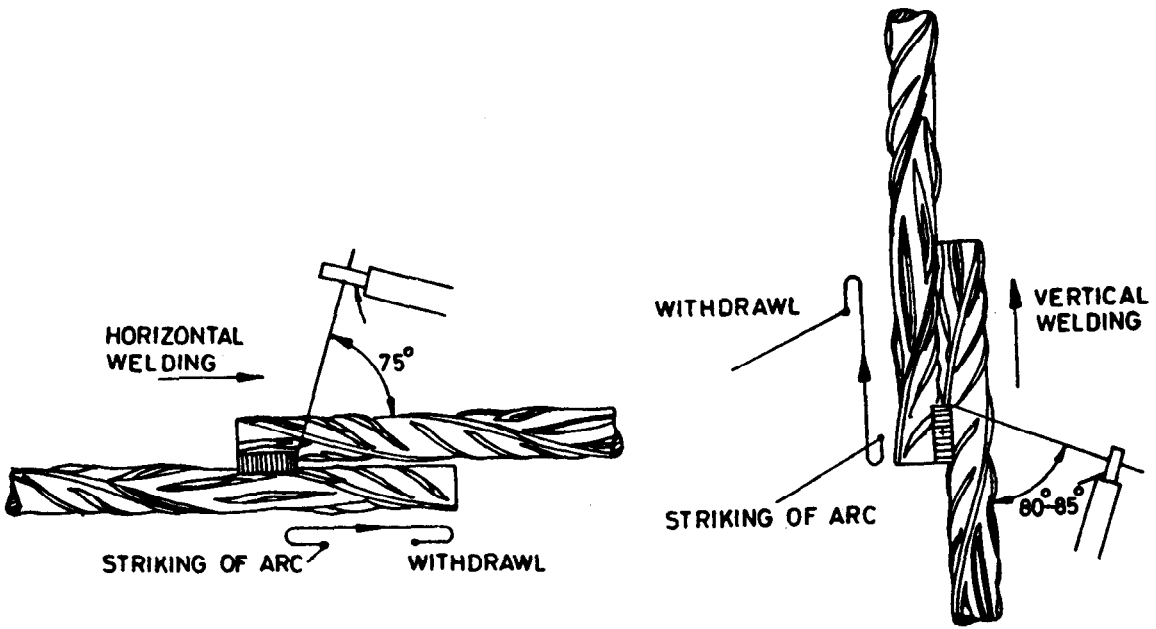

A-8A WELDING IN THE HORIZONTAL POSITION

A-8B WELDING IN THE VERTICAL POSITION

FIG. A-8 WELDING OF LAP JOINTS

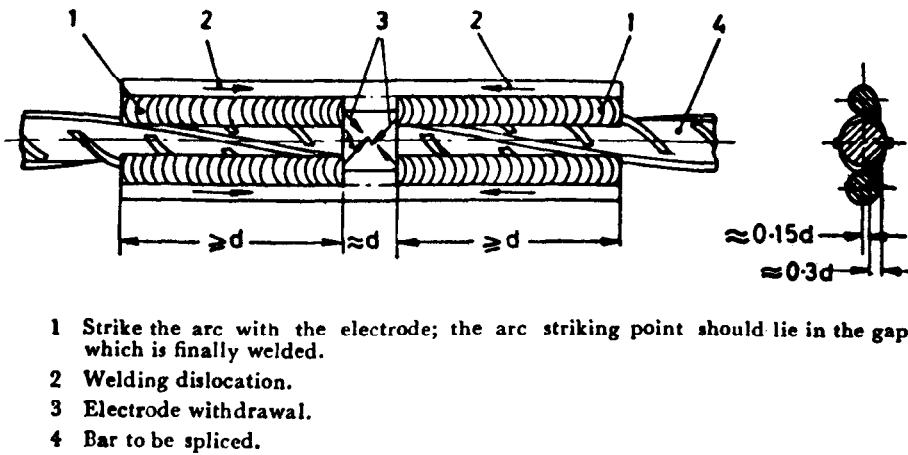

- 1 Strike the arc with the electrode; the arc striking point should lie in the gap which is finally welded.
- 2 Welding dislocation.
- 3 Electrode withdrawal.
- 4 Bar to be spliced.

FIG. A-9 LAP JOINT USING STAGES

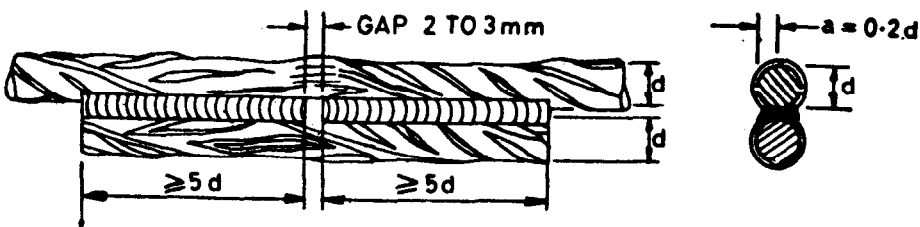

FIG. A-10 LAP JOINT

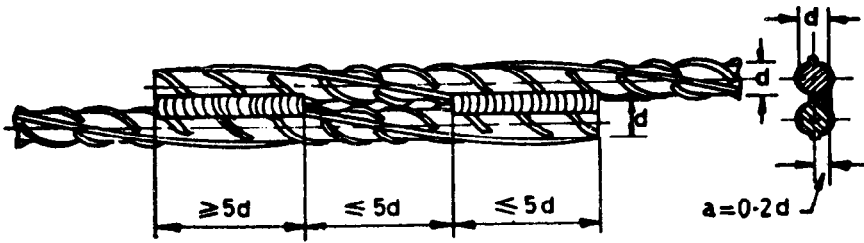

FIG. A-11 LAP JOINT

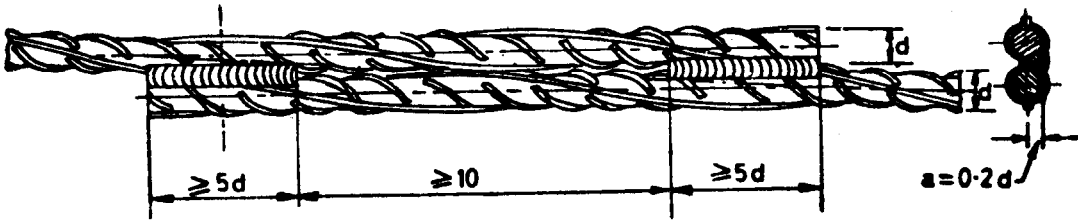

FIG. A-12 LAP JOINT

APPENDIX B

(Clause 5.9.1)

ISO 4066-1977 BUILDING AND CIVIL ENGINEERING DRAWINGS—BAR SCHEDULING*

B-0. INTRODUCTION

The purpose of this International Standard is to ensure uniformity of practice in the scheduling of steel bars for the reinforcement of concrete. To establish a clear and unambiguous system for scheduling, it is necessary to specify the method of indicating dimensions to be used and the order in which the information is given on the bar schedule.

As the use of preferred shapes is considered to be very advantageous both for simplifying design and manufacture and for the use of computers, the opportunity has been taken to include a list of preferred shapes and a coding system; the layout of the bar schedule is based on the use of preferred shapes.

B-1. SCOPE

This International Standard establishes a system for the scheduling of reinforcing bars, and comprises

- the method of indicating dimensions;
- a coding system for bar shapes;
- a list of preferred shapes;
- the bar schedule.

B-2. FIELD OF APPLICATION

This International Standard applies to all types of steel bar for the reinforcement of concrete.

Steel fabric and prestressing steel reinforcement are excluded.

B-3. METHODS OF INDICATING BENDING DIMENSIONS

The bending dimensions shall be indicated as shown in Fig. B-1 to B-5.

Dimensions shall be outside dimensions except for radii and the standard radius of bend shall be the smallest radius permitted by national standards or regulations.

The total length (cutting length) shall be calculated on the basis of the appropriate bending dimensions with corrections for bends and allowances for anchorages.

*This ISO standard is reproduced here in full as a supplement to the information contained in this handbook.

B-4. CODING SYSTEM FOR BAR SHAPES

The shape code number consists of two or, if essential, three or four characters, as defined in Table B-1.

B-5. LIST OF PREFERRED SHAPES

When a third character is used, the direction of the end anchorages shall be as shown by the dotted lines in the examples in Table B-2.

It is recognized that in some countries hooks are used for end anchorages.

The letter symbols refer to the dimensions which shall be given in the bar schedule.

B-6. BAR SCHEDULE

The bar schedule is the document used to specify and identify reinforcing bars. The format specified below incorporates the use of preferred shapes.

B-6.1 Information content

A bar schedule shall contain the following information in the sequence listed below:

- a) member — identification of the structural member in which the bar is located;
- b) bar mark — unique reference of the bar;
- c) type of steel;
- d) diameter of bar;
- e) length of each bar (cutting length, allowing for loss or gain at bends, calculated from the dimensions and radii given in (k); see B-3);
- f) number of members;
- g) number of bars in each member;
- h) total number of bars [(f) × (g)];
- j) total length [(e) × (h)];
- k) shape code (as defined in B-5);
- m) bending dimensions;
- n) revision letter;
- p) title block.

An example of a form of bar schedule is shown on page 236.

BENDING DIMENSIONS

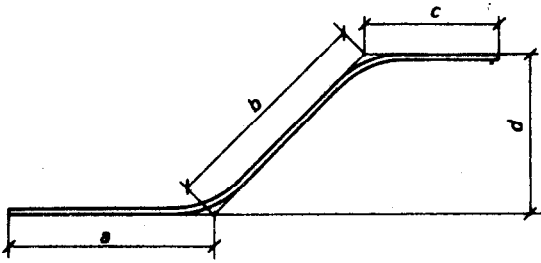

FIG. B-1

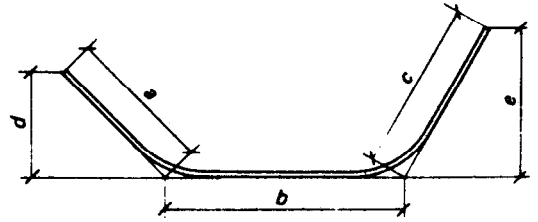

FIG. B-2

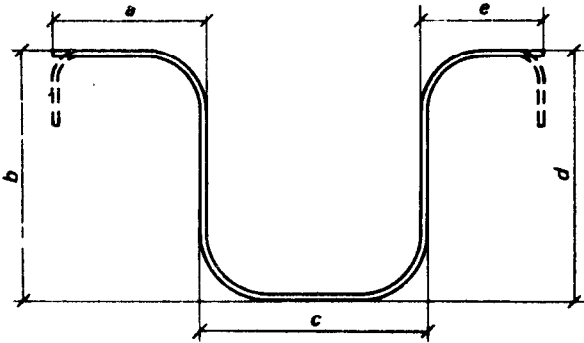

FIG. B-3

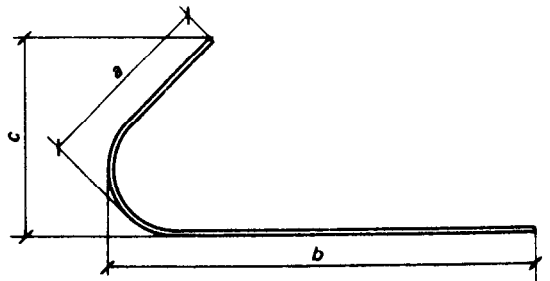
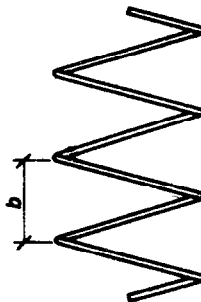
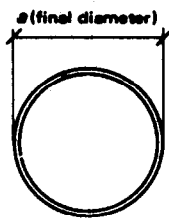

FIG. B-4



c : number of complete turns

FIG. B-5

B-6.2 Special shapes

When special shapes are required, these shall be shown by a dimensioned sketch drawn in the space normally used for bending dimensions.

B-6.3 Title Block

The title block shall be placed below the schedule, and shall contain the following information:

- a) name of the structural designer;
- b) title of the project;
- c) date prepared
prepared by ...
checked by ...

- d) drawing number;
- e) bar schedule reference;
- f) revision letter and date of last revision; and
- g) a statement that the schedule has been prepared in accordance with the requirements of ISO 4066.

B-7. SUMMARY SHEET











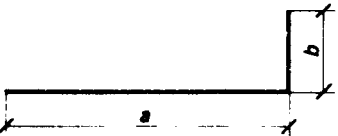

If required, summary sheets may be used; separate sheets shall be used for each type of steel.

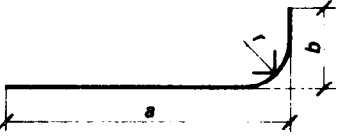
TABLE B-1 CODE NUMBER COMPOSITION

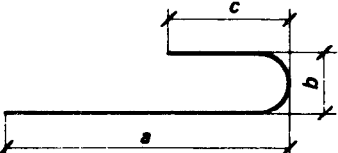
| FIRST CHARACTER | SECOND CHARACTER | THIRD CHARACTER | FOURTH CHARACTER |
|---|---|---|---|
| 0 — No bends (optional) | 0 — Straight bars (optional) | 0 — No end anchorage (optional) | S — Where a national standard specifies a special radius of bend (for example stirrups, links) this shall be indicated by use of the character S. |
| 1 — 1 bend | 1 — 90° bend(s) of standard radius all bent in the same direction | 1 — End anchorage at one end, as defined in national standards | |
| 2 — 2 bends | 2 — 90° bend(s) of non-standard radius, all bent in the same direction | 2 — End anchorages at both ends, as defined in national standards | |
| 3 — 3 bends | 3 — 180° bend(s) of non-standard radius, all bent in the same direction | | |
| 4 — 4 bends | 4 — 90° bends of standard radius not all bent in the same direction | | |
| 5 — 5 bends | 5 — Bends < 90°, all bent in the same direction | | |
| 6 — Arcs of circles | 6 — Bends < 90°, not all bent in the same direction | | |
| 7 — Helices | 7 — Arcs or helices | | |
| 81 to 89 — Shapes defined in national standards | | | |
| 99 — Special non-standard shapes defined by a sketch. It is recommended that code shapes 99 for all non-standard shapes be used. However, the numbers 91 to 99 are available for countries which require more than one number for special shapes. | | | |

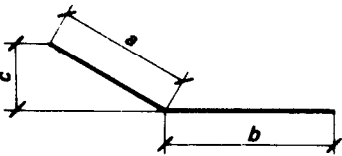
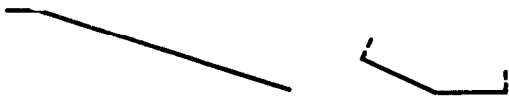
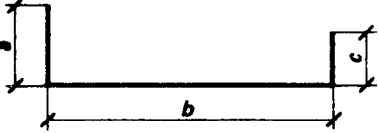
NOTE — The table explains the logic behind the numbering of the shapes in Table B-2. It is not to be used for making up codes for additional shapes.

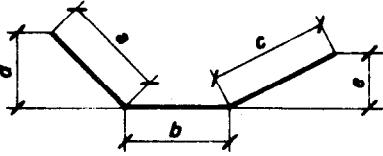
TABLE B-2 PREFERRED SHAPE

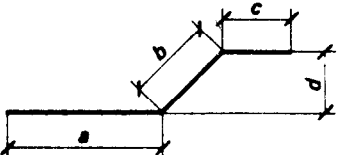
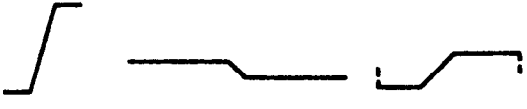
| SHAPE CODE | SHAPES | EXAMPLES |
|------------|---|--|
| 00 |  |  |
| 11 |  |  |
| 12 |  |  |
| 13 |  |  |
| 15 |  |  |
| 21 |  |  |
| 25 |  |  |
| 26 |  |  |

(Continued)

TABLE B-2 PREFERRED SHAPES — Continued

| SHAPE CODE | SHAPES | EXAMPLES |
|------------|--|----------|
| 31 | | |
| 33 | | |
| 41 | | |
| 44 | | |
| 46 | | |
| 51 | | |
| 67 | | |
| 77 | <p><i>c</i> : number of complete turns</p> | |

APPENDIX C

DIMENSIONS AND PROPERTIES OF HARD DRAWN STEEL WIRE FABRIC AND OTHER BARS

TABLE C-1 DIMENSIONS AND PROPERTIES OF HARD-DRAWN STEEL WIRE FABRIC (SQUARE AND OBLONG MESH)

| Sl. No. | MESH SIZE (NOMINAL PITCH OF WIRES) | DIAMETER OF WIRE EACH WAY | NOMINAL WEIGHT | Sl. No. | MESH SIZE (NOMINAL PITCH OF WIRES) | DIAMETER OF WIRE EACH WAY | NOMINAL WEIGHT |
|-----------------------|------------------------------------|---------------------------|-------------------|---------|------------------------------------|---------------------------|-------------------|
| (1) | (2) | (3) | (4) | (1) | (2) | (3) | (4) |
| | mm | mm | kg/m ² | | mm | mm | kg/m ² |
| A. Square Mesh | | | | | | | |
| | | | | | main | cross | |
| 1 | 50 | 3.0 | 2.220 | 55 | 75 | 300 | 2.580 |
| 2 | 50 | 3.8 | 3.560 | 56 | 75 | 300 | 2.83 |
| 3 | 50 | 3.0 | 6.160 | 57 | 75 | 300 | 3.040 |
| 4 | 100 | 3.4 | 1.430 | 58 | 75 | 300 | 3.470 |
| 5 | 100 | 3.6 | 1.600 | 59 | 75 | 300 | 3.80 |
| 6 | 100 | 4.0 | 1.980 | 60 | 75 | 300 | 4.260 |
| 7 | 100 | 4.5 | 2.530 | 61 | 75 | 300 | 4.360 |
| 8 | 100 | 4.8 | 2.840 | 62 | 75 | 300 | 5.730 |
| 9 | 100 | 5.0 | 3.080 | 63 | 75 | 300 | 7.130 |
| 10 | 100 | 5.3 | 3.460 | 64 | 75 | 300 | 8.910 |
| 11 | 100 | 5.8 | 4.140 | 65 | 75 | 400 | 7.00 |
| 12 | 100 | 6.5 | 5.200 | 66 | 75 | 400 | 7.90 |
| 13 | 100 | 7.0 | 6.040 | 67 | 75 | 400 | 8.71 |
| 14 | 100 | 8.0 | 7.900 | 68 | 75 | 400 | 5.60 |
| 15 | 150 | 3.15 | 0.82 | 69 | 75 | 400 | 4.97 |
| 16 | 150 | 3.6 | 1.060 | 70 | 75 | 400 | 4.46 |
| 17 | 150 | 4.0 | 1.320 | 71 | 75 | 400 | 3.50 |
| 18 | 150 | 4.5 | 1.660 | 72 | 100 | 150 | 1.460 |
| 19 | 150 | 4.75 | 1.85 | 73 | 100 | 150 | 1.620 |
| 20 | 150 | 5.0 | 2.060 | 74 | 100 | 150 | 1.670 |
| 21 | 150 | 5.3 | 2.300 | 75 | 100 | 150 | 1.950 |
| 22 | 150 | 5.6 | 2.57 | 76 | 100 | 150 | 1.910 |
| 23 | 150 | 5.8 | 2.760 | 77 | 100 | 150 | 2.260 |
| 24 | 150 | 6.0 | 2.360 | 78 | 100 | 150 | 2.240 |
| 25 | 150 | 6.3 | 3.27 | 79 | 100 | 150 | 2.600 |
| 26 | 150 | 6.5 | 3.480 | 80 | 100 | 150 | 3.260 |
| 27 | 150 | 7.1 | 4.14 | 81 | 100 | 150 | 3.680 |
| 28 | 150 | 7.5 | 4.62 | 82 | 100 | 250 | 1.530 |
| 29 | 150 | 8.0 | 5.260 | 83 | 100 | 250 | 1.960 |
| 30 | 150 | 9.0 | 6.660 | 84 | 100 | 250 | 2.300 |
| 31 | 150 | 10.0 | 8.220 | 85 | 100 | 250 | 3.640 |
| 32 | 200 | 4.0 | 0.980 | 86 | 100 | 300 | 1.180 |
| 33 | 200 | 4.5 | 1.260 | 87 | 100 | 300 | 1.640 |
| 34 | 200 | 4.8 | 1.420 | 88 | 100 | 300 | 1.440 |
| 35 | 200 | 5.3 | 1.740 | 89 | 100 | 300 | 1.450 |
| 36 | 200 | 5.8 | 2.080 | 90 | 100 | 300 | 1.680 |
| 37 | 200 | 6.5 | 2.600 | 91 | 100 | 300 | 2.100 |
| 38 | 200 | 7.0 | 3.020 | 92 | 100 | 300 | 1.900 |
| 39 | 200 | 8.0 | 3.940 | 93 | 100 | 300 | 1.730 |
| 40 | 200 | 9.0 | 5.300 | 94 | 100 | 300 | 2.000 |
| 41 | 200 | 10.0 | 6.160 | 95 | 100 | 300 | 2.340 |
| | | | | 96 | 100 | 300 | 2.730 |
| | | | | 97 | 100 | 300 | 2.930 |
| | | | | 98 | 100 | 300 | 3.350 |
| | | | | 99 | 100 | 300 | 3.530 |
| | | | | 100 | 100 | 300 | 3.640 |
| | | | | 101 | 100 | 300 | 4.210 |
| | | | | 102 | 100 | 300 | 4.420 |
| | | | | 103 | 100 | 300 | 4.690 |
| | | | | 104 | 100 | 300 | 4.820 |
| | | | | 105 | 100 | 300 | 5.460 |
| | | | | 106 | 100 | 300 | 6.860 |
| | | | | 107 | 150 | 250 | 1.440 |
| | | | | 108 | 150 | 250 | 3.300 |
| | | | | 109 | 150 | 250 | 3.900 |
| | | | | 110 | 150 | 300 | 2.070 |
| | | | | 111 | 150 | 300 | 2.520 |
| | | | | 112 | 150 | 300 | 3.490 |
| B. Oblong Mesh | | | | | | | |
| | main | cross | | | main | cross | |
| 42 | 75 | 250 | 5.0 | 4.2 | 2.490 | | |
| 43 | 75 | 250 | 4.2 | 4.2 | 1.09 | | |
| 44 | 75 | 250 | 6.0 | 5.0 | 3.580 | | |
| 45 | 75 | 300 | 3.15 | 2.65 | 0.96 | | |
| 46 | 75 | 300 | 3.55 | 2.65 | 1.18 | | |
| 47 | 75 | 300 | 4.0 | 2.65 | 1.45 | | |
| 48 | 75 | 300 | 4.0 | 3.0 | 1.510 | | |
| 49 | 75 | 300 | 4.5 | 3.15 | 1.870 | | |
| 50 | 75 | 300 | 4.7 | 3.15 | 2.06 | | |
| 51 | 75 | 300 | 4.8 | 3.6 | 2.160 | | |
| 52 | 75 | 300 | 5.0 | 4.2 | 2.420 | | |
| 53 | 75 | 300 | 5.0 | 5.0 | 2.600 | | |
| 54 | 75 | 300 | 5.3 | 3.15 | 2.51 | | |

TABLE C-2 REINFORCEMENT CHARACTERISTICS— AREA, WEIGHT AND PERIMETER

| SIZE | AREA | WEIGHT | PERI-METER | LENGTH PER TONNE | SIZE | AREA | WEIGHT | PERI-METER | LENGTH PER TONNE |
|------|--------------------|--------|------------|------------------|------|--------------------|--------|------------|------------------|
| (1) | (2) | (3) | (4) | (5) | (1) | (2) | (3) | (4) | (5) |
| mm | (cm ²) | (kg/m) | (cm) | (m) | mm | (cm ²) | (kg/m) | (cm) | (m) |
| 6 | 0.283 | 0.222 | 1.89 | 4310 | 22 | 3.801 | 2.980 | 6.91 | 336 |
| 8 | 0.503 | 0.395 | 2.51 | 2332 | 25 | 4.909 | 3.854 | 7.85 | 260 |
| 10 | 0.785 | 0.617 | 3.14 | 1621 | 28 | 6.157 | 4.830 | 8.80 | 207 |
| 12 | 1.131 | 0.888 | 5.77 | 1125 | 32 | 8.042 | 6.313 | 10.05 | 159 |
| 14 | 1.539 | 1.206 | 4.40 | 829 | 36 | 10.179 | 7.990 | 11.31 | 125 |
| 16 | 2.011 | 1.578 | 5.03 | 633 | 40 | 12.566 | 9.864 | 12.57 | 101 |
| 18 | 2.545 | 2.000 | 5.65 | 500 | 45 | 15.904 | 12.490 | 14.14 | 80 |
| 20 | 3.142 | 2.466 | 6.28 | 405 | 50 | 19.635 | 15.410 | 15.71 | 65 |

| NUMBER OF BARS | TABLE C-3 AREAS OF GROUPS OF STANDARDS BARS (IN SQUARE CENTIMETRES) | | | | | | | | | | | | |
|-------------------|---|-------|-------|-------|-------|-------|-------|-------|-------|-------|--------|--------|--------|
| | BAR DIAMETER IN mm | | | | | | | | | | | | |
| | 6 | 8 | 10 | 12 | 14 | 16 | 18 | 20 | 22 | 25 | 28 | 32 | 36 |
| 1 | 0.28 | 0.50 | 0.79 | 1.13 | 1.54 | 2.01 | 2.54 | 3.14 | 3.80 | 4.91 | 6.16 | 8.04 | 10.18 |
| 2 | 0.56 | 1.00 | 1.57 | 2.26 | 3.07 | 4.02 | 5.08 | 6.28 | 7.60 | 9.81 | 12.31 | 16.08 | 20.35 |
| 3 | 0.84 | 1.50 | 2.35 | 3.39 | 4.61 | 6.03 | 7.63 | 9.42 | 11.40 | 14.72 | 18.47 | 24.12 | 30.53 |
| 4 | 1.13 | 2.01 | 3.14 | 4.52 | 6.15 | 8.04 | 10.17 | 12.56 | 15.20 | 19.63 | 24.63 | 32.17 | 40.71 |
| 5 | 1.41 | 2.51 | 3.92 | 5.65 | 7.69 | 10.05 | 12.72 | 15.70 | 19.00 | 24.54 | 30.78 | 40.21 | 50.89 |
| 6 | 1.69 | 3.01 | 4.71 | 6.78 | 9.23 | 12.06 | 15.26 | 18.85 | 22.80 | 29.45 | 36.94 | 48.25 | 61.07 |
| 7 | 1.97 | 3.51 | 5.49 | 7.91 | 10.77 | 14.07 | 17.81 | 21.99 | 26.60 | 34.36 | 43.10 | 56.29 | 71.25 |
| 8 | 2.26 | 4.02 | 6.28 | 9.04 | 12.31 | 16.08 | 20.35 | 25.13 | 30.41 | 39.27 | 49.26 | 64.34 | 81.43 |
| 9 | 2.54 | 4.52 | 7.06 | 10.17 | 13.85 | 18.09 | 22.90 | 28.27 | 34.21 | 44.17 | 55.41 | 72.33 | 91.60 |
| 10 | 2.82 | 5.02 | 7.85 | 11.31 | 15.39 | 20.10 | 25.44 | 31.41 | 38.01 | 49.08 | 61.57 | 80.42 | 101.78 |
| 11 | 3.11 | 5.52 | 8.63 | 12.44 | 16.93 | 22.11 | 27.99 | 34.55 | 41.81 | 53.99 | 67.75 | 88.46 | 111.96 |
| 12 | 3.39 | 6.03 | 9.42 | 13.57 | 18.47 | 24.12 | 30.53 | 37.69 | 45.61 | 58.90 | 73.89 | 96.51 | 122.14 |
| 13 | 3.67 | 6.53 | 10.21 | 14.70 | 20.01 | 26.13 | 33.08 | 40.84 | 49.41 | 63.81 | 80.04 | 104.55 | 132.32 |
| 14 | 3.95 | 7.03 | 10.99 | 15.83 | 21.55 | 28.14 | 35.62 | 43.98 | 53.21 | 68.72 | 86.20 | 112.59 | 142.50 |
| 15 | 4.24 | 7.54 | 11.78 | 16.96 | 23.09 | 30.15 | 38.17 | 47.12 | 57.02 | 73.63 | 92.36 | 120.63 | 152.68 |
| 16 | 4.52 | 8.04 | 12.56 | 18.09 | 24.63 | 32.17 | 40.71 | 50.26 | 60.82 | 78.54 | 98.52 | 128.68 | 162.86 |
| 17 | 4.80 | 8.54 | 13.35 | 19.22 | 26.17 | 34.18 | 43.26 | 53.40 | 64.62 | 83.44 | 104.67 | 136.72 | 173.03 |
| 18 | 5.08 | 9.04 | 14.13 | 20.35 | 27.70 | 36.19 | 45.80 | 56.54 | 68.42 | 88.35 | 110.83 | 144.76 | 183.21 |
| 19 | 5.37 | 9.55 | 14.92 | 21.48 | 29.24 | 38.20 | 48.34 | 59.69 | 72.22 | 93.26 | 116.99 | 152.80 | 193.39 |
| 20 | 5.65 | 10.05 | 15.70 | 22.62 | 30.78 | 40.21 | 50.89 | 62.83 | 76.02 | 98.17 | 123.15 | 160.85 | 203.57 |

TABLE C-4 PERIMETER OF GROUPS OF STANDARD BARS (IN CENTIMETERS)

| NUMBER OF BAR | BAR DIAMETER IN mm | | | | | | | | | | | | |
|------------------|--------------------|-------|-------|-------|-------|--------|--------|--------|--------|--------|--------|--------|--------|
| | 6 | 8 | 10 | 12 | 14 | 16 | 18 | 20 | 22 | 25 | 28 | 32 | 36 |
| 1 | 1.88 | 2.51 | 3.14 | 3.77 | 4.40 | 5.03 | 5.65 | 6.28 | 6.91 | 7.85 | 8.80 | 10.05 | 11.31 |
| 2 | 3.77 | 5.02 | 6.28 | 7.54 | 8.79 | 10.05 | 11.31 | 12.56 | 13.82 | 15.70 | 17.59 | 20.10 | 22.62 |
| 3 | 5.65 | 7.54 | 9.42 | 11.31 | 13.19 | 15.08 | 16.96 | 18.85 | 20.73 | 23.56 | 26.38 | 30.15 | 33.92 |
| 4 | 7.54 | 10.05 | 12.56 | 15.08 | 17.59 | 20.10 | 22.62 | 25.13 | 27.64 | 31.41 | 35.18 | 40.21 | 45.23 |
| 5 | 9.42 | 12.56 | 15.70 | 18.85 | 21.99 | 25.13 | 28.27 | 31.41 | 34.55 | 39.27 | 43.98 | 50.26 | 56.54 |
| 6 | 11.31 | 15.08 | 18.85 | 22.62 | 26.38 | 30.15 | 33.92 | 37.69 | 41.46 | 47.12 | 52.77 | 60.31 | 67.85 |
| 7 | 13.19 | 17.59 | 21.99 | 26.38 | 30.78 | 35.18 | 39.58 | 43.98 | 48.38 | 54.97 | 61.57 | 70.37 | 79.16 |
| 8 | 15.08 | 20.10 | 25.13 | 30.15 | 35.18 | 40.21 | 45.23 | 50.26 | 55.29 | 62.83 | 70.37 | 80.42 | 90.47 |
| 9 | 16.96 | 22.62 | 28.27 | 33.92 | 39.58 | 45.23 | 50.89 | 56.54 | 62.20 | 70.68 | 79.16 | 90.47 | 101.78 |
| 10 | 18.85 | 25.13 | 31.41 | 37.69 | 43.98 | 50.26 | 56.54 | 62.83 | 69.11 | 78.54 | 87.96 | 100.53 | 113.09 |
| 11 | 20.73 | 27.64 | 34.55 | 41.46 | 48.38 | 55.29 | 62.20 | 69.11 | 76.02 | 86.39 | 96.75 | 110.59 | 124.40 |
| 12 | 22.62 | 30.15 | 37.69 | 45.23 | 52.77 | 60.31 | 67.85 | 75.39 | 82.93 | 94.24 | 105.55 | 120.63 | 135.71 |
| 13 | 24.50 | 32.67 | 40.84 | 49.00 | 57.17 | 65.34 | 73.51 | 81.68 | 89.85 | 102.10 | 114.35 | 130.69 | 147.02 |
| 14 | 26.38 | 35.18 | 43.98 | 52.77 | 61.57 | 70.37 | 79.16 | 87.96 | 96.76 | 109.95 | 123.15 | 140.74 | 158.33 |
| 15 | 28.27 | 37.69 | 47.12 | 56.54 | 65.97 | 75.39 | 84.82 | 94.24 | 103.67 | 117.81 | 131.94 | 150.79 | 169.64 |
| 16 | 30.15 | 40.21 | 50.26 | 60.31 | 70.37 | 80.42 | 90.47 | 100.53 | 110.58 | 125.66 | 140.74 | 160.85 | 180.95 |
| 17 | 32.04 | 42.72 | 53.40 | 64.08 | 74.77 | 85.45 | 96.13 | 106.81 | 117.49 | 133.51 | 149.54 | 170.90 | 192.26 |
| 18 | 33.92 | 45.23 | 56.54 | 67.95 | 79.16 | 90.47 | 101.78 | 113.09 | 124.40 | 141.37 | 158.33 | 180.95 | 203.57 |
| 19 | 35.81 | 47.75 | 59.69 | 71.62 | 83.56 | 95.50 | 107.44 | 119.38 | 131.31 | 149.22 | 167.13 | 191.00 | 214.88 |
| 20 | 37.69 | 50.26 | 62.83 | 75.39 | 87.96 | 100.53 | 113.09 | 123.66 | 138.23 | 157.08 | 175.93 | 201.06 | 226.19 |

TABLE C-5 AREA OF BARS IN SLABS (IN SQUARE CENTIMETRES PER METRE WIDTH)

| SPACING cm | BAR DIAMETER in mm | | | | | | | | | | | |
|---------------|--------------------|-------|-------|-------|-------|-------|-------|-------|-------|-------|--------|--------|
| | 6 | 8 | 10 | 12 | 14 | 16 | 18 | 20 | 22 | 25 | 28 | 32 |
| 5 | 5.65 | 10.05 | 15.71 | 22.62 | 30.79 | 40.21 | 50.89 | 62.83 | 76.03 | 98.17 | 123.15 | 160.85 |
| 6 | 4.71 | 8.38 | 13.09 | 18.85 | 25.66 | 33.51 | 42.41 | 52.36 | 63.36 | 81.81 | 102.68 | 134.04 |
| 7 | 4.04 | 7.18 | 11.22 | 16.16 | 21.99 | 28.72 | 36.35 | 44.88 | 54.30 | 70.12 | 87.96 | 114.89 |
| 8 | 3.53 | 6.28 | 9.82 | 14.14 | 19.24 | 25.13 | 31.81 | 39.27 | 47.52 | 61.36 | 76.97 | 100.53 |
| 9 | 3.14 | 5.58 | 8.73 | 12.57 | 17.10 | 22.34 | 28.27 | 34.91 | 42.24 | 54.54 | 68.42 | 89.36 |
| 10 | 2.83 | 5.03 | 7.85 | 11.31 | 15.39 | 20.11 | 25.45 | 31.42 | 38.01 | 49.09 | 61.57 | 80.42 |
| 11 | 2.57 | 4.57 | 7.14 | 10.28 | 13.99 | 18.28 | 23.13 | 28.56 | 34.56 | 44.62 | 55.98 | 73.11 |
| 12 | 2.36 | 4.19 | 6.54 | 9.42 | 12.83 | 16.75 | 21.21 | 26.18 | 31.68 | 40.91 | 51.31 | 67.02 |
| 13 | 2.17 | 3.87 | 6.04 | 8.70 | 11.84 | 15.47 | 19.57 | 24.17 | 29.24 | 37.76 | 47.37 | 61.86 |
| 14 | 2.02 | 3.59 | 5.61 | 8.08 | 11.00 | 14.36 | 18.18 | 22.44 | 27.15 | 35.06 | 43.98 | 57.45 |
| 15 | 1.88 | 3.35 | 5.24 | 7.54 | 10.26 | 13.40 | 16.96 | 20.94 | 25.34 | 32.72 | 41.05 | 53.62 |
| 16 | 1.77 | 3.14 | 4.91 | 7.07 | 9.62 | 12.57 | 15.90 | 19.63 | 23.76 | 30.68 | 38.48 | 50.27 |
| 17 | 1.66 | 2.96 | 4.62 | 6.65 | 9.05 | 11.83 | 14.97 | 18.48 | 22.36 | 28.87 | 36.22 | 47.31 |
| 18 | 1.57 | 2.79 | 4.36 | 6.28 | 8.55 | 11.17 | 14.44 | 17.45 | 21.12 | 27.27 | 34.21 | 44.68 |
| 19 | 1.49 | 2.65 | 4.13 | 5.95 | 8.10 | 10.58 | 13.39 | 16.53 | 20.01 | 25.84 | 32.41 | 42.33 |
| 20 | 1.41 | 2.51 | 3.93 | 5.65 | 7.70 | 10.05 | 12.72 | 15.71 | 19.01 | 24.54 | 30.79 | 40.21 |
| 21 | 1.35 | 2.39 | 3.74 | 5.39 | 7.33 | 9.57 | 12.12 | 14.96 | 18.10 | 23.37 | 29.32 | 38.30 |
| 22 | 1.28 | 2.28 | 3.57 | 5.14 | 7.00 | 9.14 | 11.57 | 14.28 | 17.28 | 22.31 | 27.99 | 36.56 |
| 23 | 1.23 | 2.18 | 3.41 | 4.92 | 6.69 | 8.74 | 11.06 | 13.66 | 16.53 | 21.34 | 26.77 | 34.97 |
| 24 | 1.18 | 2.09 | 3.27 | 4.71 | 6.41 | 8.38 | 10.60 | 13.09 | 15.84 | 20.54 | 25.66 | 33.51 |
| 25 | 1.13 | 2.01 | 3.14 | 4.52 | 6.15 | 8.04 | 10.18 | 12.57 | 15.20 | 19.63 | 24.63 | 32.17 |
| 26 | 1.09 | 1.93 | 3.02 | 4.35 | 5.92 | 7.73 | 9.79 | 12.08 | 14.62 | 18.88 | 23.68 | 30.93 |
| 27 | 1.05 | 1.86 | 2.91 | 4.19 | 5.70 | 7.45 | 9.42 | 11.64 | 14.08 | 18.18 | 22.81 | 29.79 |
| 28 | 1.01 | 1.79 | 2.80 | 4.04 | 5.50 | 7.18 | 9.09 | 11.22 | 13.58 | 17.53 | 21.99 | 28.76 |
| 29 | 0.97 | 1.73 | 2.71 | 3.90 | 5.31 | 6.93 | 8.77 | 10.83 | 13.11 | 16.93 | 21.23 | 27.73 |
| 30 | 0.94 | 1.68 | 2.62 | 3.77 | 5.13 | 6.70 | 8.48 | 10.47 | 12.67 | 16.36 | 20.52 | 26.81 |
| 32 | 0.88 | 1.57 | 2.45 | 3.53 | 4.81 | 6.28 | 7.95 | 9.82 | 11.88 | 15.34 | 19.24 | 25.13 |
| 34 | 0.83 | 1.48 | 2.31 | 3.33 | 4.53 | 5.91 | 7.48 | 9.24 | 11.18 | 14.44 | 18.11 | 23.65 |
| 36 | 0.78 | 1.40 | 2.18 | 3.14 | 4.28 | 5.58 | 7.07 | 8.73 | 10.56 | 13.63 | 17.10 | 22.34 |
| 38 | 0.74 | 1.32 | 2.07 | 2.98 | 4.05 | 5.29 | 6.70 | 8.27 | 10.00 | 12.92 | 16.20 | 21.15 |
| 40 | 0.71 | 1.26 | 1.96 | 2.83 | 3.85 | 5.03 | 6.36 | 7.85 | 9.50 | 12.27 | 15.39 | 20.11 |

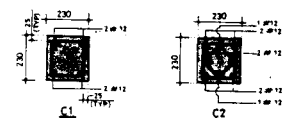
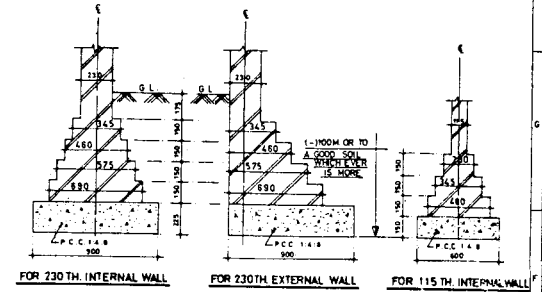
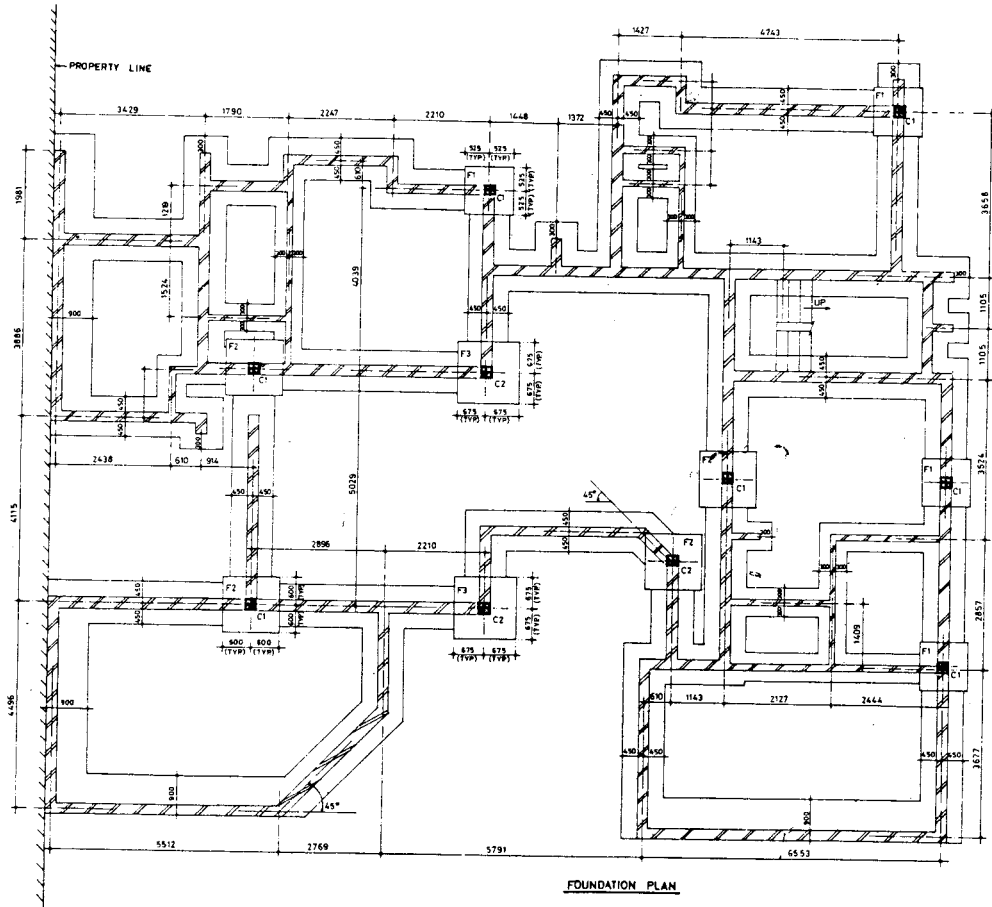

FOOTING SCHEDULE

| FOOTING MARK | DIMENSIONS IN M M | | | RFT SPACING IN M M | | REMARKS |
|--------------|-------------------|------|-----|--------------------|---------|---------|
| | L | B | D | HL | VB | |
| F1 | 1050 | 1050 | 250 | #10@140 | #10@140 | |
| F2 | 1200 | 1200 | 300 | #10@120 | #10@120 | |
| F3 | 1950 | 1350 | 300 | #10@100 | #10@100 | |

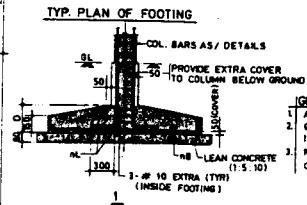
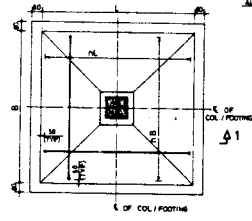

- GENERAL NOTES:**
1. ALL DIMENSIONS ARE IN M M UNLESS NOTED OTHERWISE.
 2. GRADE OF CONCRETE MIX SHALL BE M15 CONFORMING TO IS: 456-1978.
 3. REINFORCEMENT SHALL BE HIGH STRENGTH DEFORMED BARS OF GRADE Fe 415 CONFORMING TO IS: 1786-1985.

FOUNDATION DETAIL OF ISOLATED FOOTING.

SHEET - I

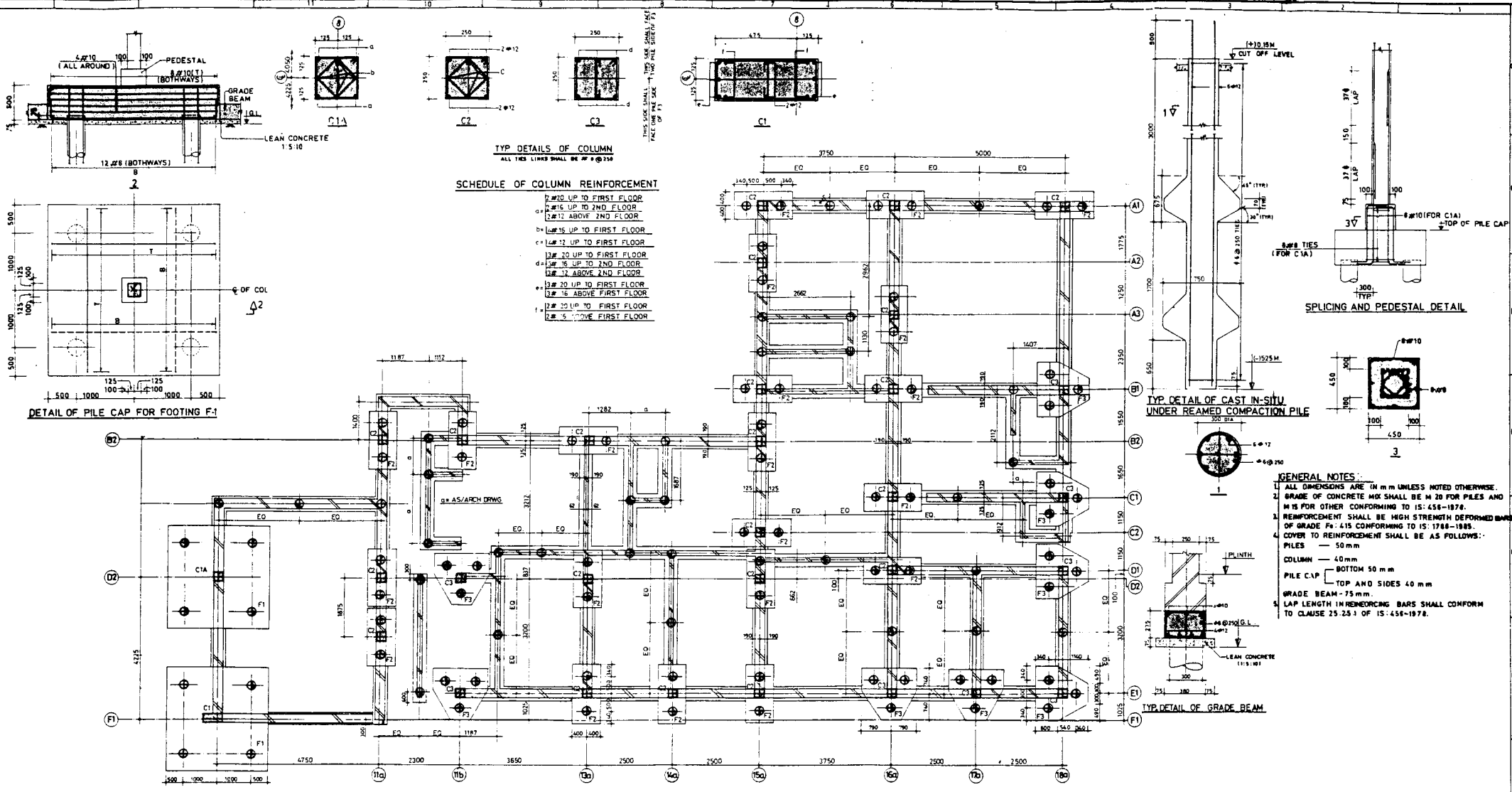

TYP DETAILS OF COLUMN
ALL TIES SHALL BE # 8 @ 150

SCHEDULE OF COLUMN REINFORCEMENT

- a. 2#20 UP TO FIRST FLOOR
- b. 2#16 UP TO 2ND FLOOR
- c. 2#12 ABOVE 2ND FLOOR
- d. 4#16 UP TO FIRST FLOOR
- e. 4#12 UP TO FIRST FLOOR
- f. 2#20 UP TO FIRST FLOOR
- g. 2#16 UP TO 2ND FLOOR
- h. 2#12 ABOVE 2ND FLOOR
- i. 2#20 UP TO FIRST FLOOR
- j. 2#16 ABOVE FIRST FLOOR

DETAIL OF PILE CAP FOR FOOTING F-1

SPlicing AND PEDESTAL DETAIL

TYP DETAIL OF CAST IN-SITU UNDER REAMED COMPACTION PILE

- GENERAL NOTES:
1. ALL DIMENSIONS ARE IN mm UNLESS NOTED OTHERWISE.
 2. GRADE OF CONCRETE MIX SHALL BE M 20 FOR PILES AND M 15 FOR OTHER CONFORMING TO IS: 456-1978.
 3. REINFORCEMENT SHALL BE HIGH STRENGTH DEFORMED BARS OF GRADE Fe 415 CONFORMING TO IS: 1786-1985.
 4. COVER TO REINFORCEMENT SHALL BE AS FOLLOWS:
 - PILES — 50 mm
 - COLUMN — 40 mm
 - PILE CAP — BOTTOM 50 mm
 - TOP AND SIDES 40 mm
 5. LAP LENGTH IN REINFORCING BARS SHALL CONFORM TO CLAUSE 25.25.1 OF IS: 456-1978.

FOUNDATION PLAN
LAYOUT OF BUILDING SHALL BE DONE AS PER ARCHT DRWG

FOUNDATION DETAILS PILES, PILE CAP AND GRADE BEAM

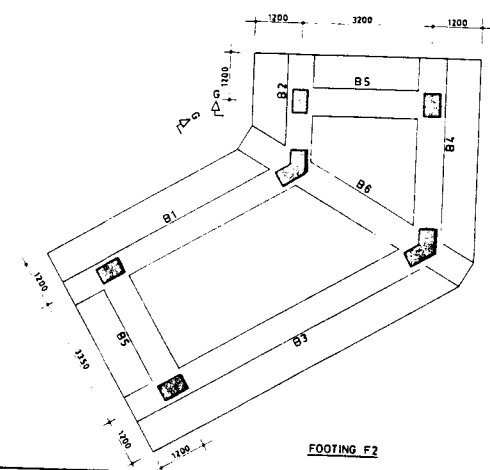
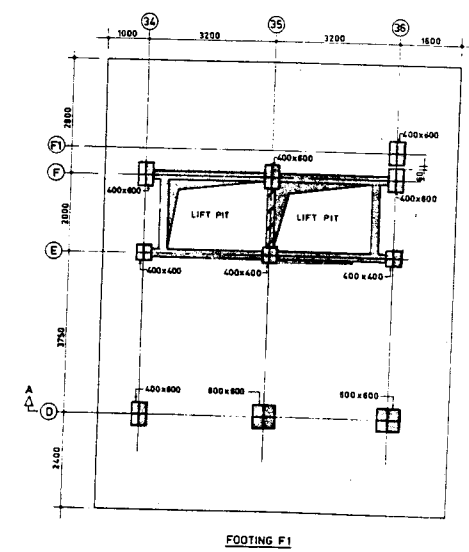
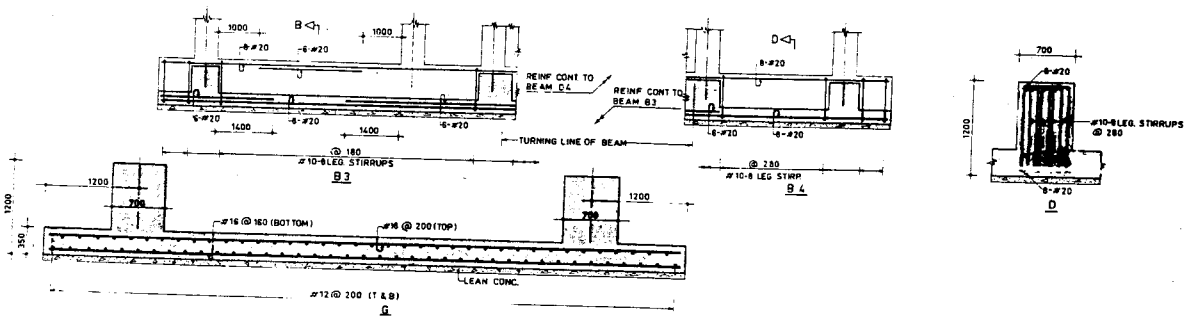
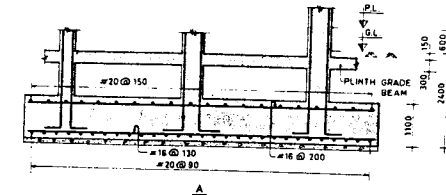
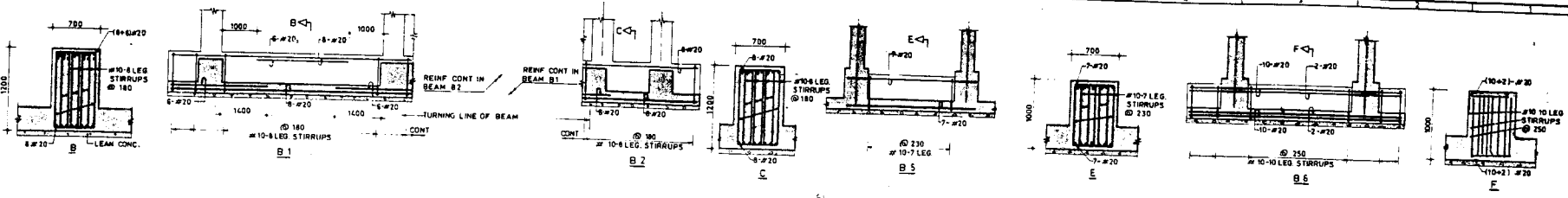

GENERAL NOTES
 1. ALL DIMENSIONS ARE IN M.M. UNLESS NOTED OTHERWISE.
 2. GRADE OF CONCRETE MIX SHALL BE M15 CONFORMING TO IS 456-1978.
 3. REINFORCEMENT SHALL BE HIGH STRENGTH DEFORMED BARS OF GRADE F4.415 CONFORMING TO IS 1786-1985.
 4. COVER TO REINFORCEMENT SHALL BE 75 M.M. AT THE BOTTOM AND 50 M.M. AT TOP AND SIDES FOR FOOTINGS.

DETAILS OF A SIMPLE RAFT FOOTING
 SHEET-3

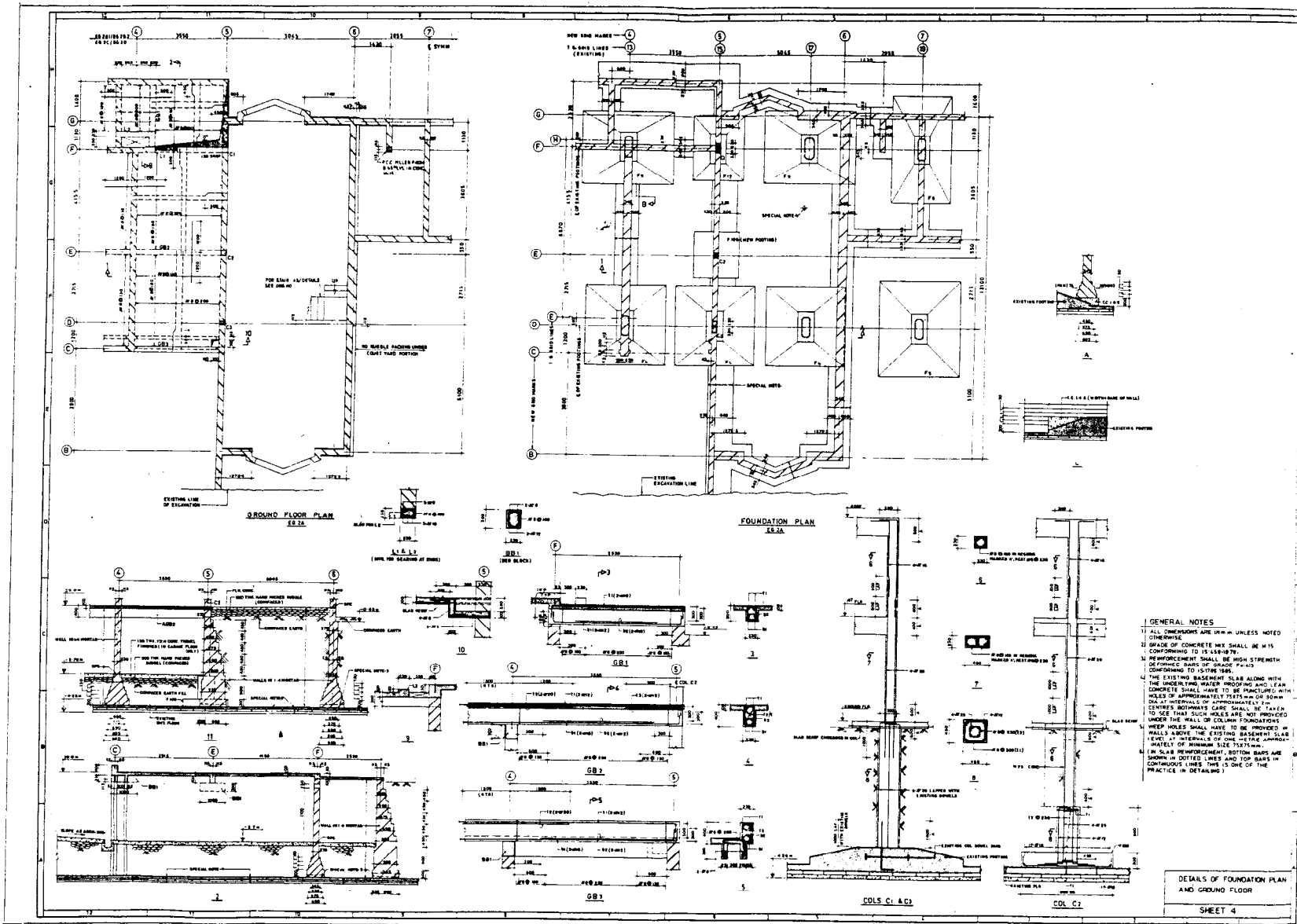

- GENERAL NOTES**
1. ALL DIMENSIONS ARE IN MM UNLESS NOTED OTHERWISE.
 2. GRADE OF CONCRETE MIX SHALL BE M15 CONFORMING TO IS 456-1977.
 3. REINFORCEMENT SHALL BE HIGH STRENGTH DEFORMED BARS OF GRADE Fe 415 CONFORMING TO IS 1786-1983.
 4. THE EXISTING BASEMENT SLAB ALONG WITH THE UNDERLAYER WATER PROOFING AND LEAK HOLES OR APPROXIMATELY 150mm OR 30mm DIA AT INTERVALS OF APPROXIMATELY 1.5m TO SEE THAT SUCH HOLES ARE NOT PROVIDED UNDER THE WALL OR COLUMN FOUNDATIONS.
 5. WEEP HOLES SHALL HAVE TO BE PROVIDED IN WALLS ABOVE THE EXISTING BASEMENT SLAB LEVEL AT INTERVALS OF ONE METRE APPROXIMATELY OF MINIMUM SIZE 75x75mm.
 6. IN SLAB REINFORCEMENT, BOTTOM BARS ARE SHOWN IN DOTTED LINES AND TOP BARS IN CONTINUOUS LINES THIS IS ONE OF THE PRACTICE IN DETAILING.

DETAILS OF FOUNDATION PLAN AND GROUND FLOOR
SHEET 4

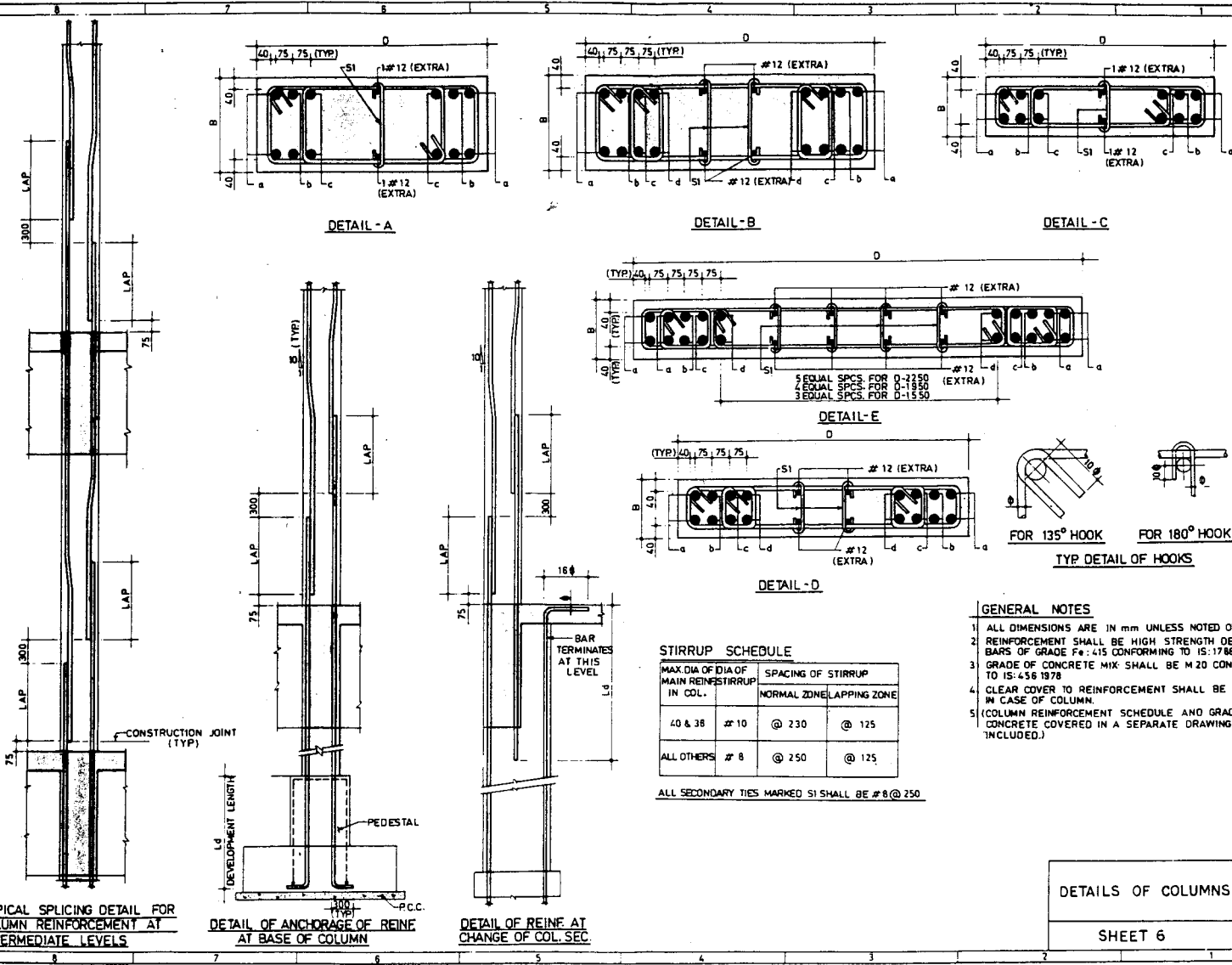

TYPICAL SPlicing DETAIL FOR COLUMN REINFORCEMENT AT INTERMEDIATE LEVELS

DETAIL OF ANCHORAGE OF REIN AT BASE OF COLUMN

DETAIL OF REIN. AT CHANGE OF COL. SEC.

STIRRUP SCHEDULE

| MAX. DIA OF DIA OF MAIN REIN STIRRUP IN COL. | SPACING OF STIRRUP | NORMAL ZONE/LAPPING ZONE | |
|--|--------------------|--------------------------|-------|
| | | | |
| 40 & 38 | $\#10$ | @ 230 | @ 125 |
| ALL OTHERS | $\#8$ | @ 250 | @ 125 |

ALL SECONDARY TIES MARKED S1 SHALL BE $\#8 @ 250$

DETAILS OF COLUMNS

SHEET 6

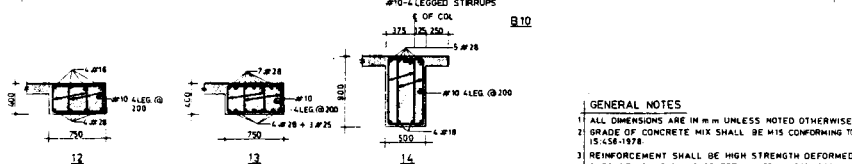
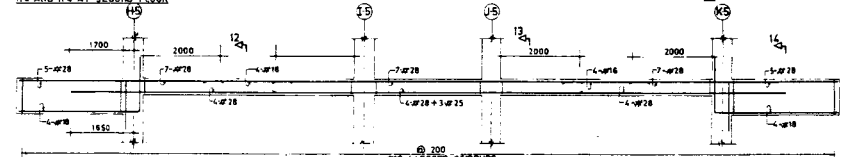
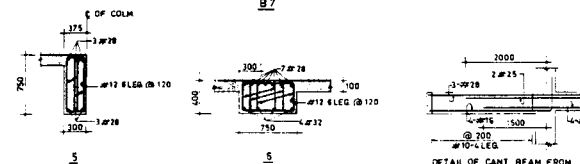
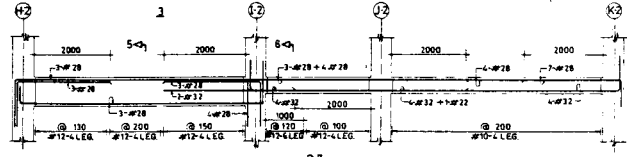
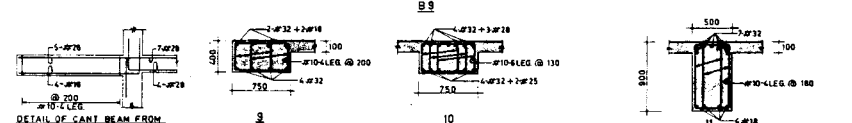
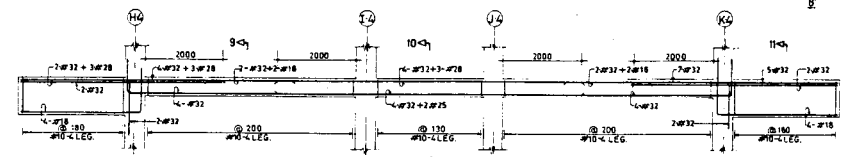
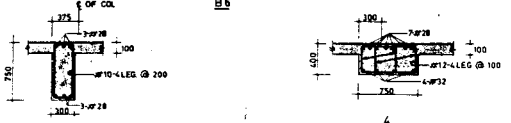
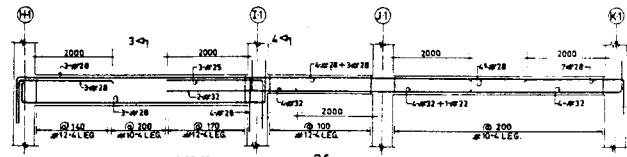
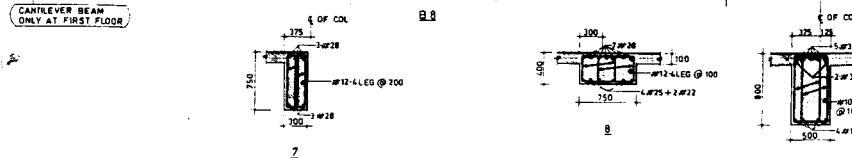
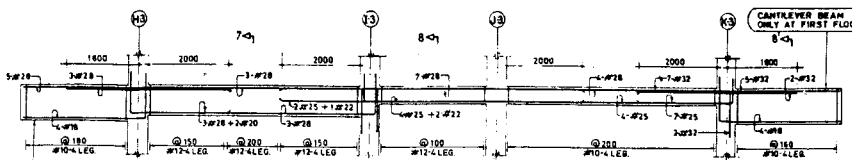
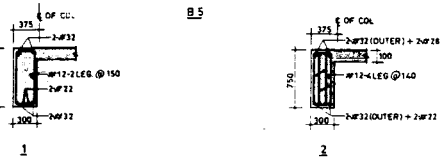
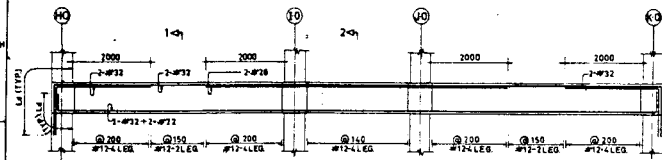

DETAIL OF CANT BEAM FROM H4 AND H4 AT SECOND FLOOR

DETAIL OF CANT BEAM FROM H5 AND H5 AT SECOND FLOOR (BEAM SECTION 500X500)

- GENERAL NOTES**
- 1 ALL DIMENSIONS ARE IN mm UNLESS NOTED OTHERWISE
 - 2 GRADE OF CONCRETE MIX SHALL BE M15 CONFORMING TO IS:456-1978
 - 3 REINFORCEMENT SHALL BE HIGH STRENGTH DEFORMED BARS OF GRADE Fe415 CONFORMING TO IS:1786-1985
 - 4 COVER TO REINFORCEMENT SHALL BE 25 mm OR THE DIAMETER OF THE BAR WHICHEVER IS GREATER

DETAILS OF BEAMS
(INCORPORATING DUCTILITY PROVISIONS FOR SEISMIC DESIGN)
SHEET 7

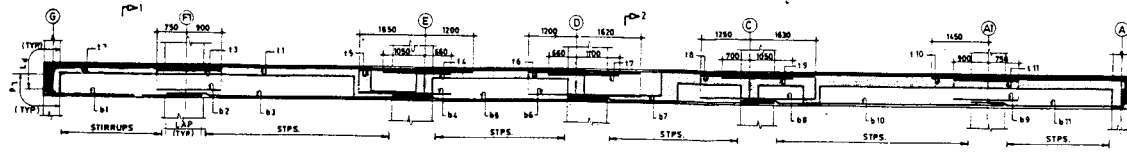

BEAM ALONG GRID 1 & 13

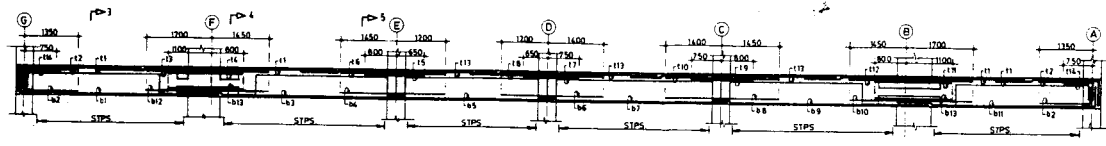
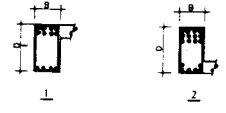

BEAM ALONG GRID 2 & 17

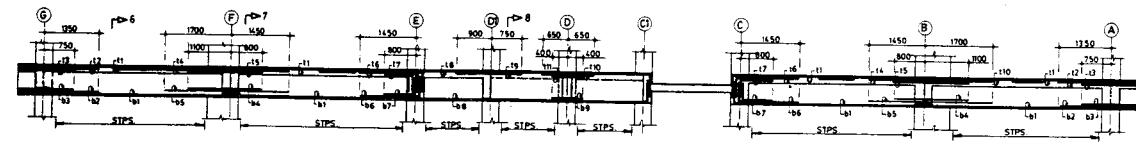
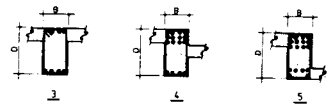

BEAM ALONG GRID 3 & 11

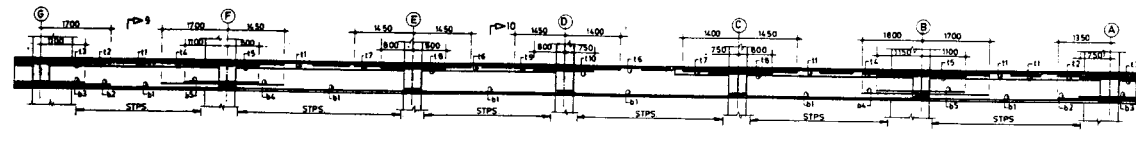
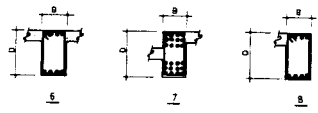

BEAM ALONG GRID 4 & 10

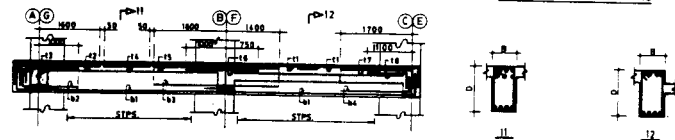
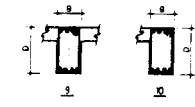

BEAM ALONG GRID 5 & 9

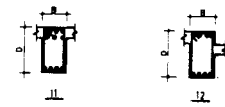

- GENERAL NOTES**
1. ALL DIMENSIONS ARE IN MM UNLESS NOTED OTHERWISE.
 2. GRADE OF CONCRETE MIX SHALL BE M15 CONFORMING TO IS:456-1978
 3. REINFORCEMENT SHALL BE HIGH STRENGTH DEFORMED BARS OF GRADE F_y 415 CONFORMING TO IS: 1786-1985.
 4. COVER TO REINFORCEMENT SHALL BE 25 mm OR DIAMETER OF LARGER BAR WHICHEVER IS GREATER.
 5. (STIRRUPS SCHEDULE NOT INCLUDED)

DETAILS OF BEAMS FOR
MULTISTORY BUILDING
(SEISMIC DESIGN)
SEE SHEET 8 FOR REINFORCEMENT SCHEDULE
SHEET 8

DETAILS OF REINFORCEMENT FOR MAIN & SECTION BEAMS FOR 1ST FLOOR

| NO. | DESCRIPTION OF BEAMS | GRADE OF MIX. | CLEAR SPAN. | WIDTH | OVERALL DEPTH | REINFORCEMENT | | | | | | STIRRUPS | | | | | | | | | | | |
|-----|--|---------------|-------------|-------|---------------|---------------|-----------|-----------|-----------|-------------|-----------|-------------|-----|--------|------|-------------|-----|------|------|----|---|-----|------|
| | | | | | | 1st SUPPORT | | CENTRE | | 2nd SUPPORT | | 1st SUPPORT | | CENTRE | | 2nd SUPPORT | | | | | | | |
| | | | | | | TOP | BOTTOM | TOP | BOTTOM | TOP | BOTTOM | DIA | LEG | Ø | DIST | DIA | LEG | Ø | DIST | | | | |
| 1 | L1 - L1 | M 20 | 2850 | 230 | 400 | 2-25 | 2-20+1-12 | 2-25 | 2-20+1-12 | 2-25+1-18 | 2-20+1-12 | 8 | 4 | 120 | 285 | 8 | 2 | 240 | 1060 | 8 | 4 | 120 | 285 |
| 2 | L1 - L2, L2 - L3 | M 20 | 5800 | 400 | 600 | 2-25+1-16 | 2-25+1-16 | 2-25 | 2-25+1-16 | 2-25+3-16 | 2-25+1-16 | 8 | 4 | 120 | 1740 | 8 | 2 | 240 | 2200 | 8 | 4 | 120 | 1740 |
| 3 | K1 - K4 | M 15 | 5800 | 400 | 600 | 2-28+3-25 | 3-25 | 2-28 | 3-25+2-20 | 2-28+3-25 | 3-25 | 8 | 4 | 160 | 1740 | 8 | 2 | 360 | 2320 | 8 | 4 | 160 | 1740 |
| 4 | M1 - M3 | M 15 | 5800 | 400 | 600 | 2-28+3-25 | 3-25 | 2-28 | 3-25 | 5-28 | 3-25 | 8 | 4 | 160 | 1740 | 8 | 2 | 360 | 2320 | 8 | 4 | 160 | 1740 |
| 5 | K3 - K9 | M 15 | 5800 | 400 | 600 | 5-28 | 3-25 | 2-28 | 2-25+2-20 | 3-28+2-20 | 3-25 | 10 | 4 | 150 | 1740 | 10 | 2 | 150 | 2320 | 10 | 4 | 150 | 1740 |
| 6 | J1 - J4 | M 15 | 5800 | 400 | 600 | 2-28+3-20 | 3-20 | 2-28 | 3-20 | 2-28+3-20 | 3-20 | 8 | 4 | 160 | 1740 | 8 | 2 | 320 | 2320 | 8 | 4 | 160 | 1740 |
| 7 | J1 - J4 | M 15 | 5800 | 400 | 600 | 2-28+3-20 | 3-20 | 2-28 | 3-20 | 4-28+3-15 | 3-20 | 8 | 4 | 160 | 1740 | 8 | 2 | 320 | 2320 | 8 | 4 | 160 | 1740 |
| 8 | J1 - J2 | M 15 | 5800 | 400 | 600 | 4-28+3-25 | 5-20 | 2-28 | 7-20 | 4-28+1-25 | 5-20 | 8 | 6 | 180 | 1740 | 8 | 7 | 360 | 2320 | 8 | 6 | 180 | 1740 |
| 9 | I1 - I4 | M 15 | 5775 | 400 | 600 | 2-28+3-25 | 3-20 | 2-28 | 3-20 | 2-28+3-25 | 3-20 | 8 | 4 | 150 | 1740 | 8 | 2 | 360 | 2295 | 8 | 4 | 150 | 1740 |
| 10 | I1 - I3 | M 15 | 5775 | 400 | 600 | 2-28+3-25 | 3-20 | 2-28 | 3-20 | 4-28+3-25 | 3-25+2-20 | 8 | 4 | 150 | 1740 | 8 | 2 | 300 | 2295 | 8 | 6 | 150 | 1740 |
| 11 | J1 - J2 | M 15 | 5800 | 400 | 600 | 4-28+3-25 | 3-25+2-20 | 2-28 | 3-25+2-20 | 4-28+3-20 | 3-25 | 8 | 6 | 180 | 1740 | 8 | 2 | 360 | 2320 | 8 | 6 | 180 | 1740 |
| 12 | Q1-M1-Q1 | M 20 | 4075 | 300 | 600 | | | | | | | 8 | 4 | 180 | 1225 | 8 | 2 | 360 | 1625 | 8 | 4 | 180 | 1225 |
| 13 | Q1-M1-Q1 | M 20 | 175 | 300 | 600 | 3-25+2-20 | 3-25 | 2-25 | 3-25 | 3-25+2-20 | 3-25 | 8 | 4 | 100 | 355 | 8 | 2 | 360 | 465 | 8 | 4 | 100 | 355 |
| 14 | Q1-M1-Q1 | M 20 | 2675 | 300 | 600 | | | | | | | 8 | 4 | 180 | 725 | 8 | 2 | 360 | 1025 | 8 | 4 | 180 | 725 |
| 15 | Q1-M1-Q1 | M 20 | 2900 | 300 | 600 | 3-25+2-20 | 3-25 | 2-25 | 3-25 | 3-25+2-20 | 3-25 | 8 | 4 | 100 | 870 | 8 | 2 | 300 | 1160 | 8 | 4 | 100 | 870 |
| 16 | Q1-M1-Q1 | M 20 | 2000 | 300 | 600 | | | | | | | 8 | 4 | 100 | 585 | 8 | 2 | 300 | 930 | 8 | 4 | 100 | 585 |
| 17 | M1 - M2 | M 20 | 3300 | 300 | 600 | 3-25+2-20 | 3-25 | 2-25 | 3-25 | 5-25 | 3-25 | 8 | 4 | 120 | 990 | 8 | 2 | 300 | 1320 | 8 | 4 | 120 | 990 |
| 18 | R - S (TO BE DERESSED BY 480 mm) | M 20 | 7800 | 300 | 600 | 5-25 | 7-25+1-20 | 2-25 | 2-25+1-20 | 5-25 | 3-25 | 8 | 4 | 130 | 1140 | 8 | 2 | 360 | 1520 | 8 | 4 | 120 | 1140 |
| 19 | Q1-P - M | M 20 | 4150 | 300 | 600 | 5-25 | 7-25+1-20 | 2-25 | 2-25+1-20 | 5-25 | 2-25+1-20 | 8 | 4 | 180 | 1250 | 8 | 2 | 360 | 1650 | 8 | 4 | 180 | 1250 |
| 20 | N1-M - Q1 | M 15 | 2900 | 300 | 600 | 5-25 | 7-25+1-20 | 2-25 | 2-25+1-20 | 5-25 | 2-25+3-20 | 8 | 4 | 180 | 870 | 8 | 2 | 360 | 1160 | 8 | 6 | 180 | 870 |
| 21 | Q1 - Q1' | M 15 | 2000 | 300 | 600 | 5-25 | 7-25+3-20 | 2-25 | 2-25+1-20 | 5-25 | 2-25+3-20 | 8 | 6 | 180 | 585 | 8 | 2 | 360 | 830 | 8 | 6 | 180 | 585 |
| 22 | Q1 - Q1 (FOR LIV. REF. STRUCTURAL DRG NO. 1) | M 15 | 3400 | 300 | 600 | 5-25 | 7-25+3-20 | 2-25 | 2-25+1-20 | 5-25 | 2-25+1-20 | 8 | 6 | 180 | 1020 | 8 | 2 | 360 | 1380 | 8 | 4 | 180 | 1020 |
| 23 | G1 - H1 | M 20 | 8200 | 400 | 600 | 3-25+2-20 | 3-20 | 2-25 | 3-20 | 3-25+2-20 | 3-20 | 8 | 4 | 160 | 1880 | 8 | 2 | 360 | 2480 | 8 | 4 | 160 | 1880 |
| 24 | H1 - I1, I1 - J1, J1 - K1, K1 - L1 | M 20 | 5800 | 250 | 875 | 3-25+2-20 | 3-20 | 2-25 | 3-20 | 3-25+2-20 | 3-20 | 8 | 4 | 180 | 1740 | 8 | 2 | 360 | 2320 | 8 | 4 | 180 | 1740 |
| 25 | Q1 - H1' | M 15 | 8200 | 400 | 600 | 2-25+3-20 | 2-20+1-16 | 2-25 | 2-20+1-16 | 2-25+3-20 | 2-20+1-16 | 8 | 4 | 180 | 1880 | 8 | 2 | 360 | 2480 | 8 | 4 | 180 | 1880 |
| 26 | G1 - H1 | M 15 | 8200 | 400 | 600 | 2-25+3-20 | 3-25 | 2-25 | 3-25 | 3-25+3-20 | 3-25 | 8 | 4 | 180 | 1880 | 8 | 2 | 360 | 2480 | 8 | 4 | 180 | 1880 |
| 27 | H1 - I1 | M 15 | 5775 | 400 | 600 | 2-25+3-20 | 3-25 | 2-25 | 3-25 | 3-25+2-20 | 5-28 | 8 | 4 | 110 | 1740 | 8 | 2 | 360 | 2295 | 8 | 4 | 110 | 1740 |
| 28 | J1 - J2, J2 - K1, K1 - L1 | M 15 | 5775 | 400 | 600 | 5-28 | 3-25 | 2-28 | 3-25+2-20 | 5-28 | 3-25 | 8 | 4 | 110 | 1740 | 8 | 2 | 360 | 2295 | 8 | 4 | 110 | 1740 |
| 29 | M1-M - S | M 20 | 2880 | 300 | 900 | 3-20 | 3-18 | 2-20 | 3-16 | 3-20 | 3-16 | 8 | 4 | 180 | 880 | | | 1100 | | 8 | 4 | 180 | 880 |
| 30 | N1-S - N | M 20 | 3240 | 300 | 900 | 3-20 | 3-18 | 2-20 | 3-16 | 3-20 | 3-16 | 8 | 4 | 180 | 880 | | | 1300 | | 8 | 4 | 180 | 880 |
| 31 | M1 - L1, L1 - J1 | M 15 | 5775 | 400 | 600 | 5-28 | 2-28+1-25 | 2-28 | 2-28+1-25 | 5-28 | 2-28+1-25 | 8 | 4 | 110 | 1740 | 8 | 2 | 360 | 2295 | 8 | 4 | 110 | 1740 |
| 32 | J1 - K1, K1 - L1 | M 15 | 5800 | 400 | 600 | 5-28 | 2-28+1-25 | 2-28 | 2-28+2-25 | 5-28+2-20 | 3-28 | 8 | 4 | 110 | 1740 | 8 | 2 | 360 | 2320 | 8 | 4 | 110 | 1740 |
| 33 | Q1-P - R | M 20 | 2980 | 300 | 100 | 2-20+1-16 | 3-16 | 2-20+1-16 | 3-16 | 2-20+1-16 | 3-16 | 8 | 4 | 180 | 880 | | | 1100 | | 8 | 4 | 180 | 880 |
| 34 | N1-R - Q | M 20 | 3240 | 300 | 100 | 2-20+1-16 | 3-16 | 2-20+1-16 | 3-16 | 2-20+1-16 | 3-16 | 8 | 4 | 180 | 880 | | | 1300 | | 8 | 4 | 180 | 880 |
| 35 | H1 - I1 | M 20 | 5800 | 250 | 875 | 3-28+3-25 | 5-20 | 2-28 | 5-20 | 3-28+3-25 | 5-20 | 8 | 6 | 180 | 1740 | 8 | 2 | 400 | 2320 | 8 | 6 | 180 | 1740 |
| 36 | I1 - J1 | M 20 | 5800 | 250 | 875 | 3-28+3-25 | 5-20 | 2-28 | 3-20 | 2-28+3-25 | 3-20 | 8 | 6 | 180 | 1740 | 8 | 2 | 400 | 2320 | 8 | 6 | 180 | 1740 |
| 37 | J1 - K1 | M 20 | 5800 | 250 | 875 | 3-28+3-25 | 3-20 | 2-28 | 3-20 | 2-28+3-25 | 3-20 | 8 | 6 | 180 | 1740 | 8 | 2 | 380 | 2320 | 8 | 4 | 180 | 1740 |
| 38 | K1 - K1 | M 20 | 2850 | 250 | 400 | 5-25 | 3-20 | 2-25 | 3-20 | 3-25 | 3-20 | 8 | 4 | 180 | 795 | 8 | 2 | 380 | 1080 | 8 | 4 | 180 | 795 |
| 39 | K1 - K1 | M 20 | 4122 | 300 | 400 | 2-25+1-20 | 3-20 | 2-25 | 5-20 | 2-25+1-20 | 3-20 | 8 | 4 | 150 | 1240 | 8 | 2 | 300 | 1652 | 8 | 4 | 150 | 1240 |

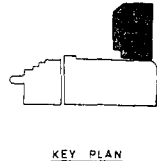

KEY PLAN

- GENERAL NOTES**
- ALL DIMENSIONS ARE IN 'm' UNLESS NOTED OTHERWISE.
 - REINFORCEMENT SHALL BE HIGH STRENGTH DEFORMED BARS OF GRADE BY I/S CONFORMING TO IS 1786: 1985.
 - COVER TO LONGITUDINAL BARS IN BEAMS SHALL BE NOT LESS THAN 25mm, NOT LESS THAN THE DIAMETER OF BAR.
 - IN BEAM NOTATION (USED), FIRST FIGURE INDICATES IN COLUMN NO AT FIRST SUPPORT AND SECOND FIGURE IS THE COLUMN NUMBER ON THE SECOND SUPPORT.
 - FOR SECONDARY BEAMS PARALLEL TO THE HORIZONTAL AXIS LEFT AND RIGHT SUPPORTS ARE DEFINED AS FIRST & SECOND SUPPORT RESPECTIVELY. FOR BEAMS PARALLEL TO THE VERTICAL AXIS, THE LOWER AND UPPER SUPPORTS ARE DEFINED AS FIRST & SECOND SUPPORT RESPECTIVELY.
 - REINFORCEMENT IS REPRESENTED BY TWO NUMBERS THE FIRST NUMBER INDICATES NUMBER OF BARS AND THE SECOND NUMBER INDICATES DIAMETER OF BARS.

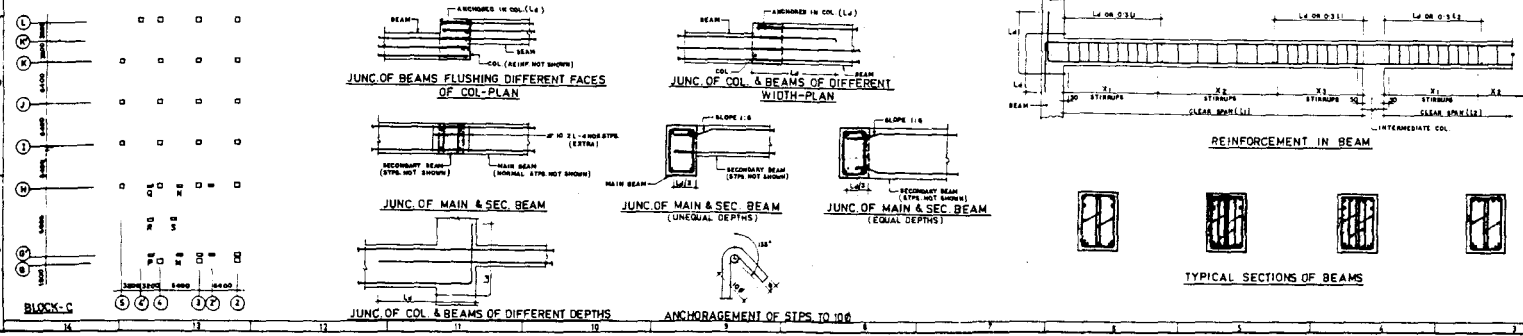

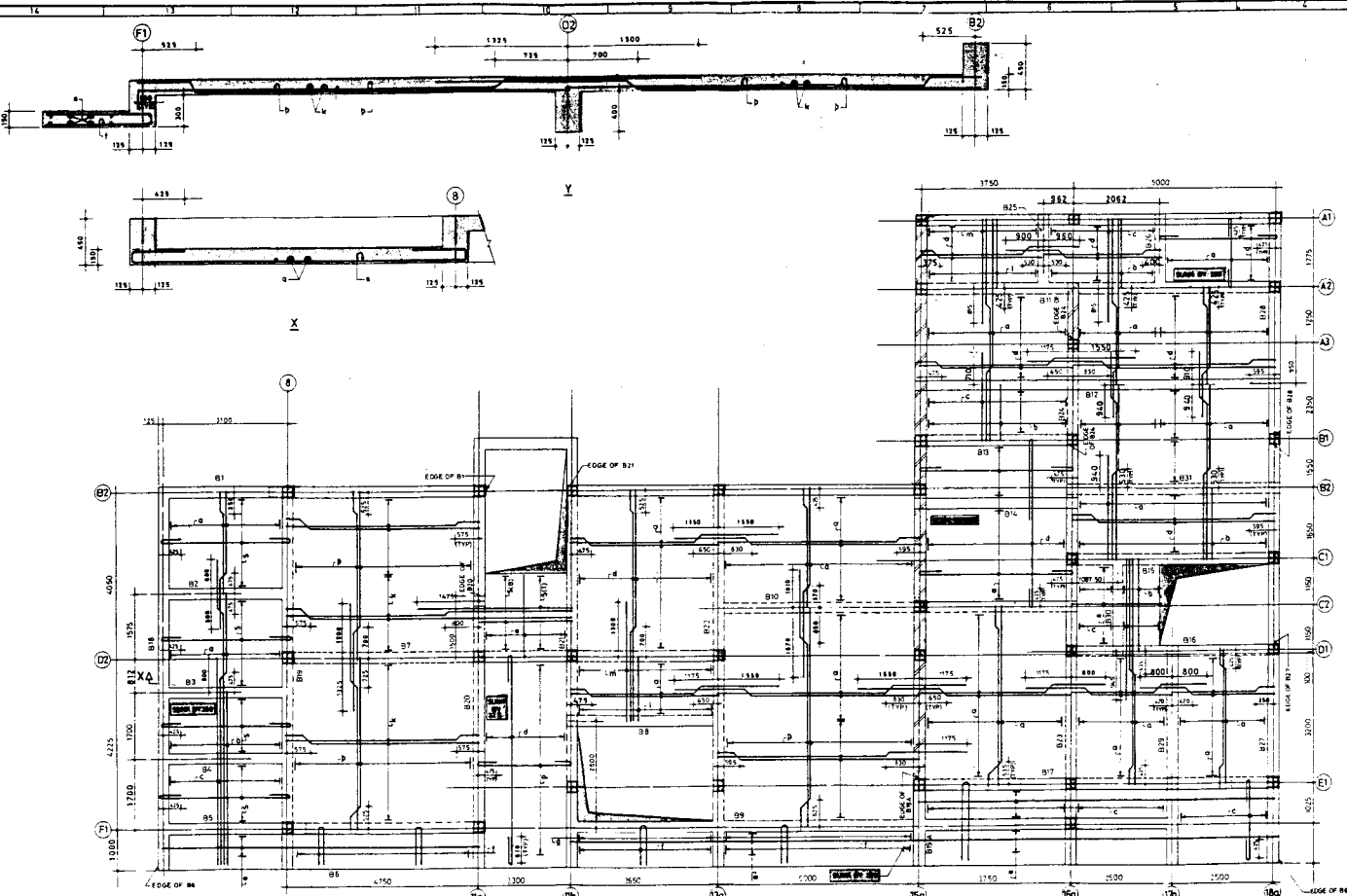

FRAMING PLAN AT SECOND FLOOR
 ALL SLABS SHALL BE 150MM UNLESS NOTED OTHERWISE

- LEGEND:**
- a = #8 @ 200 (ALT)
 - b = #8 @ 400 (B)
 - c = #8 @ 400 (T)
 - d = #8 @ 250 (T & B)
 - e = #8 @ 200 (T & B)
 - f = #10 @ 100 (T & B)
 - g = #8 @ 100 (ALT)
 - h = #8 @ 500 (B)
 - m = #8 @ 500 (T)
 - p = #8 @ 100 (ALT)
 - r = #8 @ 150 (T & B)
 - s = #8 @ 360 (T & B)
 - T = TOP
 - B = BOTTOM

- GENERAL NOTES**
- 1 ALL DIMENSIONS ARE IN mm UNLESS NOTED OTHERWISE
 - 2 GRADE OF CONCRETE MIX SHALL BE M 15 CONFORMING TO IS: 456-1978
 - 3 REINFORCEMENT SHALL BE HIGH STRENGTH DEFORMED BARS OF GRADE Fe 415 CONFORMING TO IS: 1786-1983
 - 4 CLEAR COVER TO REINFORCEMENT SHALL BE 15mm

DETAILS OF SLAB
 (USING BENT-UP BARS)
 SHEET II

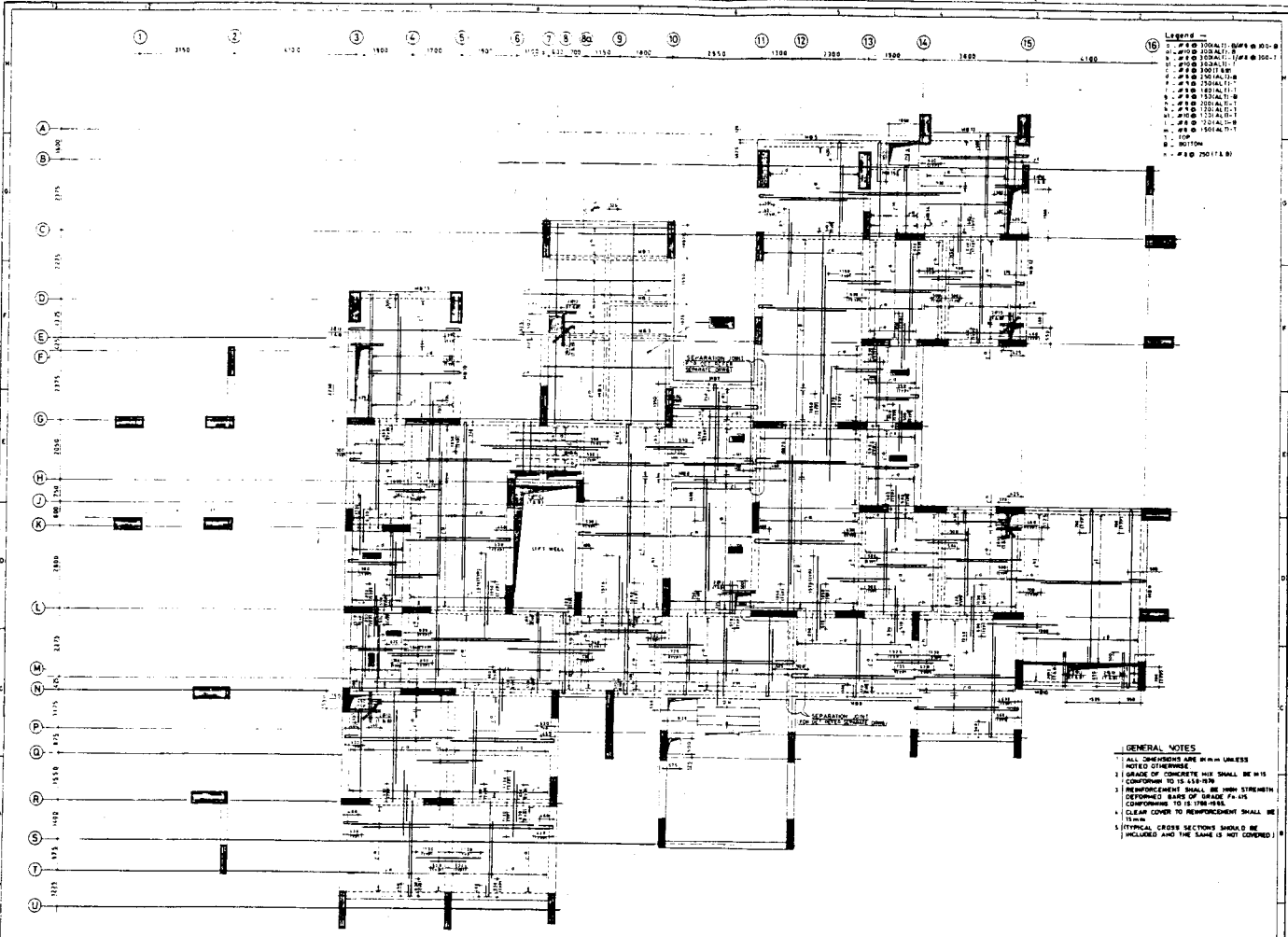

- Legend**
- 1. # 8 @ 200AL-T
 - 2. # 8 @ 200AL-T
 - 3. # 8 @ 200AL-T
 - 4. # 8 @ 200AL-T
 - 5. # 8 @ 200AL-T
 - 6. # 8 @ 200AL-T
 - 7. # 8 @ 200AL-T
 - 8. # 8 @ 200AL-T
 - 9. # 8 @ 200AL-T
 - 10. # 8 @ 200AL-T
 - 11. # 8 @ 200AL-T
 - 12. # 8 @ 200AL-T
 - 13. # 8 @ 200AL-T
 - 14. # 8 @ 200AL-T
 - 15. # 8 @ 200AL-T
 - 16. # 8 @ 200AL-T
 - 17. # 8 @ 200AL-T
 - 18. # 8 @ 200AL-T
 - 19. # 8 @ 200AL-T
 - 20. # 8 @ 200AL-T
 - 21. # 8 @ 200AL-T
 - 22. # 8 @ 200AL-T
 - 23. # 8 @ 200AL-T
 - 24. # 8 @ 200AL-T
 - 25. # 8 @ 200AL-T
 - 26. # 8 @ 200AL-T
 - 27. # 8 @ 200AL-T
 - 28. # 8 @ 200AL-T
 - 29. # 8 @ 200AL-T
 - 30. # 8 @ 200AL-T
 - 31. # 8 @ 200AL-T
 - 32. # 8 @ 200AL-T
 - 33. # 8 @ 200AL-T
 - 34. # 8 @ 200AL-T
 - 35. # 8 @ 200AL-T
 - 36. # 8 @ 200AL-T
 - 37. # 8 @ 200AL-T
 - 38. # 8 @ 200AL-T
 - 39. # 8 @ 200AL-T
 - 40. # 8 @ 200AL-T
 - 41. # 8 @ 200AL-T
 - 42. # 8 @ 200AL-T
 - 43. # 8 @ 200AL-T
 - 44. # 8 @ 200AL-T
 - 45. # 8 @ 200AL-T
 - 46. # 8 @ 200AL-T
 - 47. # 8 @ 200AL-T
 - 48. # 8 @ 200AL-T
 - 49. # 8 @ 200AL-T
 - 50. # 8 @ 200AL-T
 - 51. # 8 @ 200AL-T
 - 52. # 8 @ 200AL-T
 - 53. # 8 @ 200AL-T
 - 54. # 8 @ 200AL-T
 - 55. # 8 @ 200AL-T
 - 56. # 8 @ 200AL-T
 - 57. # 8 @ 200AL-T
 - 58. # 8 @ 200AL-T
 - 59. # 8 @ 200AL-T
 - 60. # 8 @ 200AL-T
 - 61. # 8 @ 200AL-T
 - 62. # 8 @ 200AL-T
 - 63. # 8 @ 200AL-T
 - 64. # 8 @ 200AL-T
 - 65. # 8 @ 200AL-T
 - 66. # 8 @ 200AL-T
 - 67. # 8 @ 200AL-T
 - 68. # 8 @ 200AL-T
 - 69. # 8 @ 200AL-T
 - 70. # 8 @ 200AL-T
 - 71. # 8 @ 200AL-T
 - 72. # 8 @ 200AL-T
 - 73. # 8 @ 200AL-T
 - 74. # 8 @ 200AL-T
 - 75. # 8 @ 200AL-T
 - 76. # 8 @ 200AL-T
 - 77. # 8 @ 200AL-T
 - 78. # 8 @ 200AL-T
 - 79. # 8 @ 200AL-T
 - 80. # 8 @ 200AL-T
 - 81. # 8 @ 200AL-T
 - 82. # 8 @ 200AL-T
 - 83. # 8 @ 200AL-T
 - 84. # 8 @ 200AL-T
 - 85. # 8 @ 200AL-T
 - 86. # 8 @ 200AL-T
 - 87. # 8 @ 200AL-T
 - 88. # 8 @ 200AL-T
 - 89. # 8 @ 200AL-T
 - 90. # 8 @ 200AL-T
 - 91. # 8 @ 200AL-T
 - 92. # 8 @ 200AL-T
 - 93. # 8 @ 200AL-T
 - 94. # 8 @ 200AL-T
 - 95. # 8 @ 200AL-T
 - 96. # 8 @ 200AL-T
 - 97. # 8 @ 200AL-T
 - 98. # 8 @ 200AL-T
 - 99. # 8 @ 200AL-T
 - 100. # 8 @ 200AL-T

- GENERAL NOTES**
1. ALL DIMENSIONS ARE IN MM UNLESS NOTED OTHERWISE.
 2. GRADE OF CONCRETE MIX SHALL BE M15 CONFORMING TO IS 456:1987.
 3. REINFORCEMENT SHALL BE HRB 250 CONFORMING TO IS 1786:1983.
 4. CLEAR COVER TO REINFORCEMENT SHALL BE 25MM.
 5. TYPICAL CROSS SECTIONS SHOULD BE INCLUDED AND THE SAME IS NOT COVERED.

FRAMING PLAN AT MEZZANINE FLOOR
IN PLAN SCALE IS 1:50

DETAILS OF SLAB
(USING STRAIGHT BARS)
SHEET 12

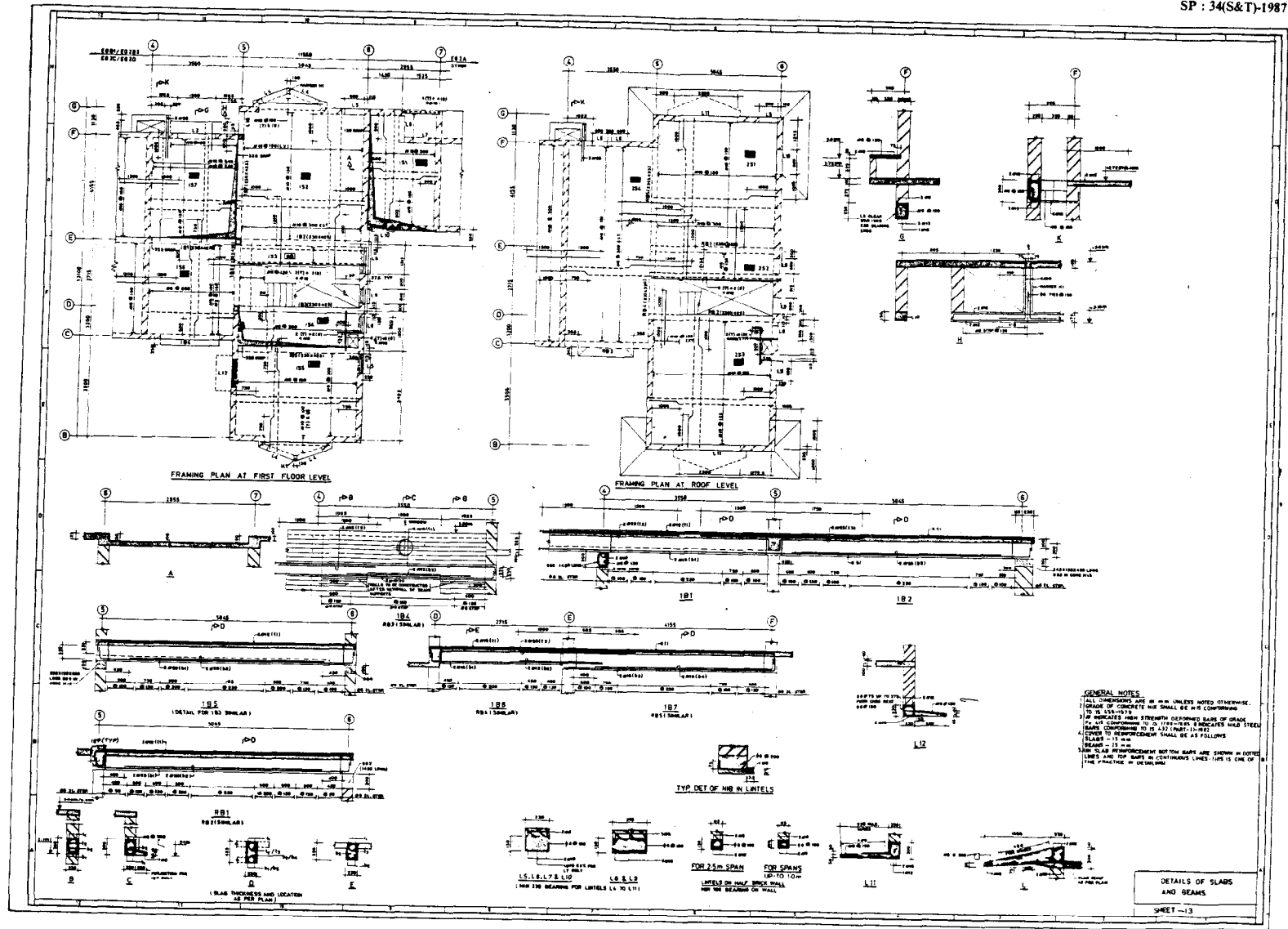

GENERAL NOTES

1. ALL DIMENSIONS ARE IN MM UNLESS NOTED OTHERWISE.
2. GRADE OF CONCRETE MIX SHALL BE M 40 CONFORMING TO IS 456-1978.
3. IF INDICATED WITH STRENGTH DESIGNATED BASE OF GRADE SHALL CONFORM TO IS 1171-1973. INDICATED HAD STEEL COVER TO REINFORCEMENT SHALL BE AS FOLLOWS:
 - SLABS - 15 mm
 - BEAMS - 25 mm
4. TOP SLAB REINFORCEMENT BOTTOM BARS ARE SHOWN IN CUTTED LINES AND TOP BARS IN CONTINUOUS LINES. THIS IS ONE OF THE PRACTICE IN DRAWING.

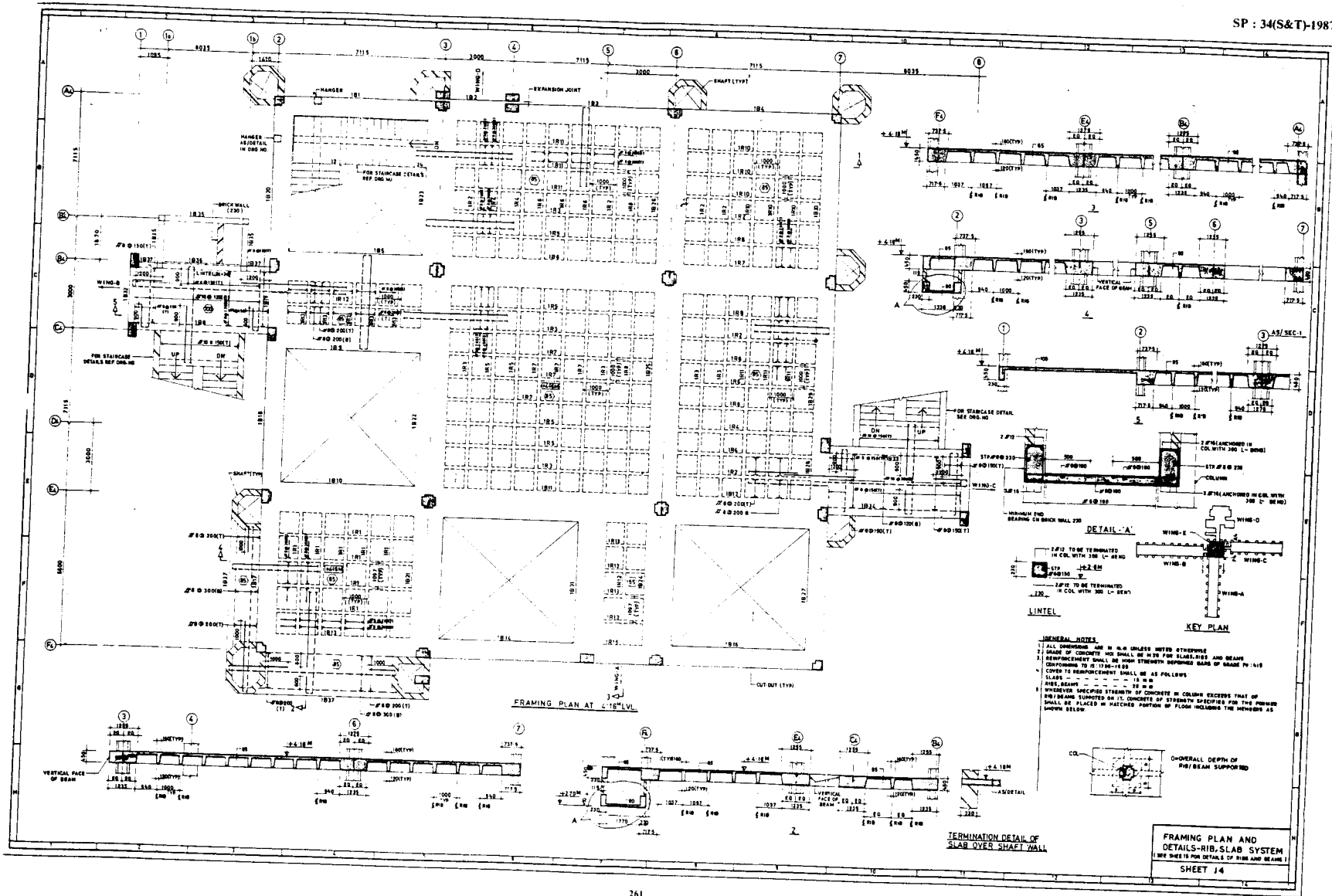

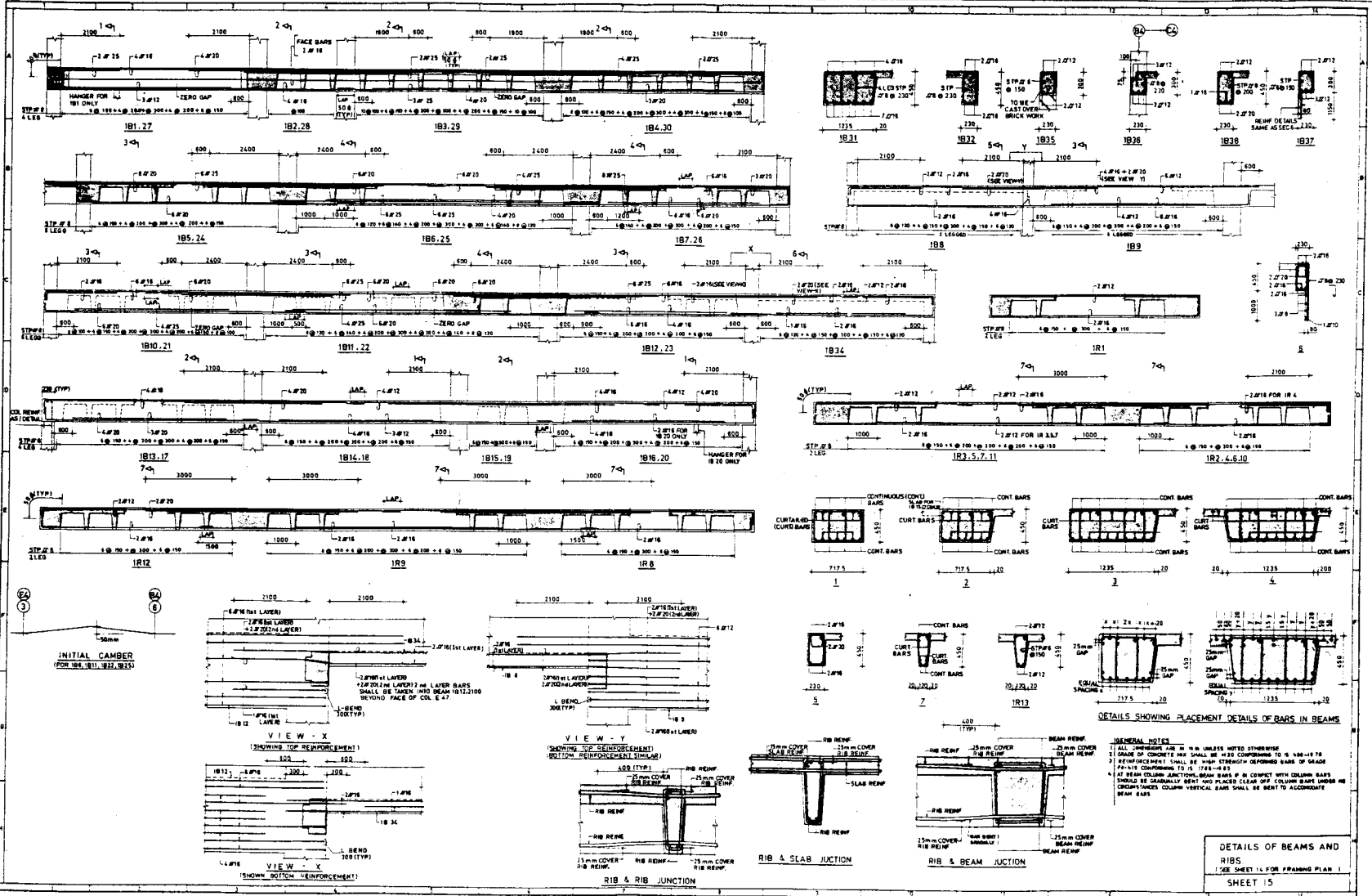

DETAILS SHOWING PLACEMENT DETAILS OF BARS IN BEAMS

- GENERAL NOTES**
1. ALL DIMENSIONS ARE IN M.M. UNLESS NOTED OTHERWISE
 2. GRADE OF CONCRETE MIX SHALL BE AS PER REQUIREMENTS TO S. 40-10-10
 3. REINFORCEMENT SHALL BE HIGH STRENGTH DEFORMED BARS OF GRADE Fe-415 CONFORMING TO IS 1786-1983
 4. AT BEAM COLUMN JUNCTIONS, BEAM BARS Φ IN CONTACT WITH COLUMN BARS SHOULD BE MANUALLY BENT AND PLACED CLEAR OF COLUMN BARS UNDER ALL CIRCUMSTANCES COLUMN VERTICAL BARS SHALL BE BENT TO ACCOMMODATE BEAM BARS

DETAILS OF BEAMS AND RIBS
 SEE SHEET 16 FOR FRAMING PLAN
 SHEET 15

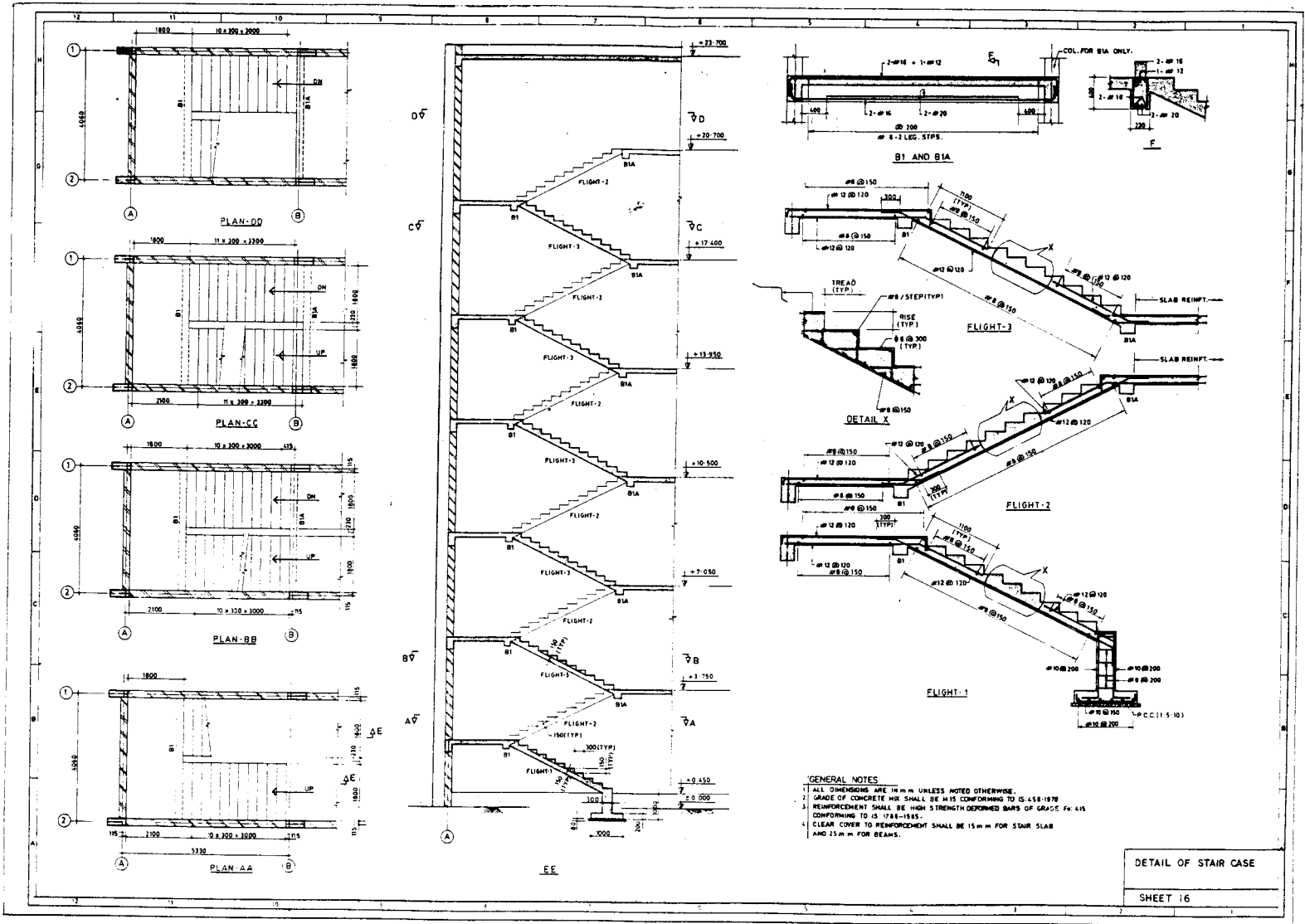

DETAIL OF STAIR CASE

SHEET 16

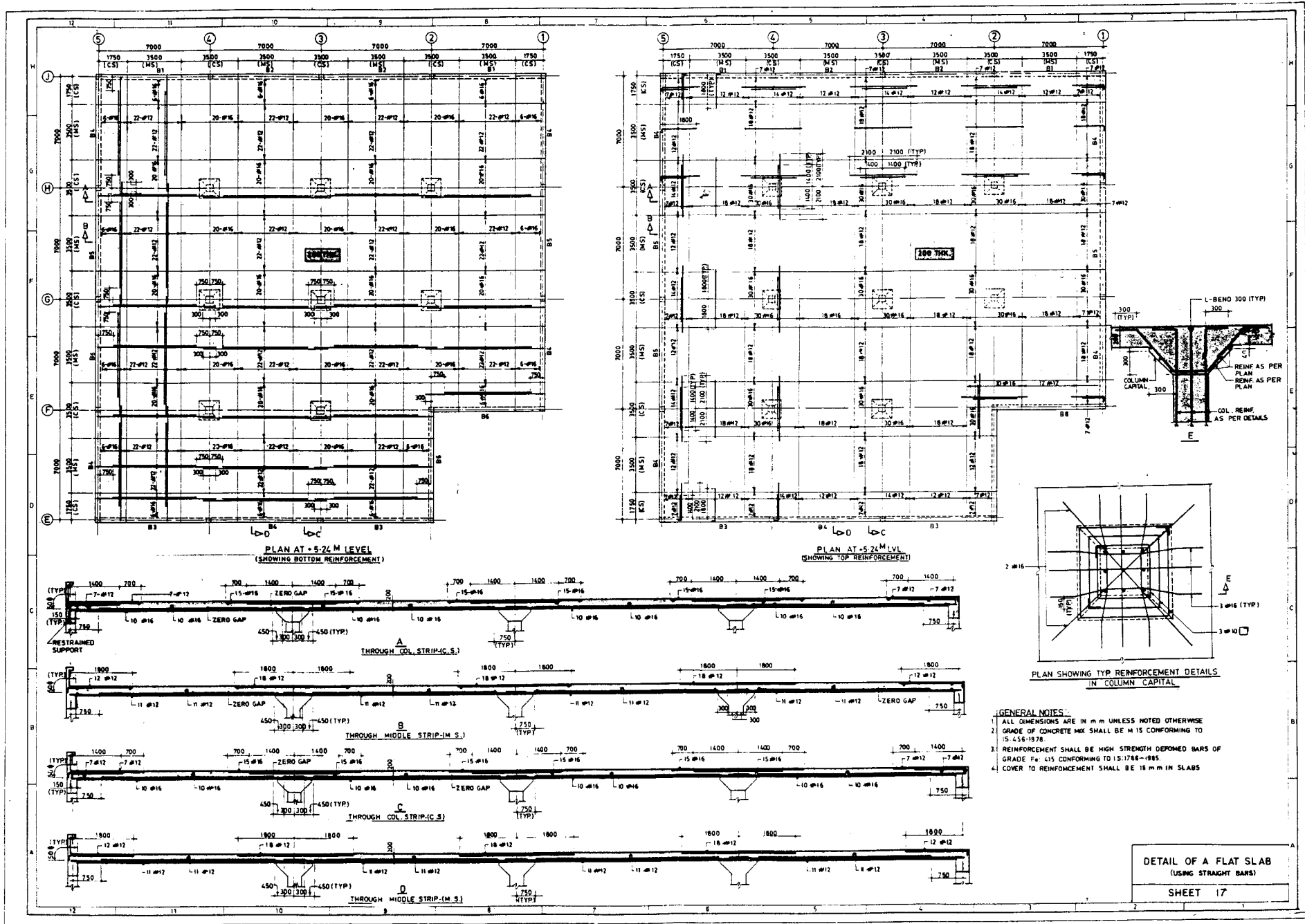

- GENERAL NOTES:**
1. ALL DIMENSIONS ARE IN M UNLESS NOTED OTHERWISE
 2. GRADE OF CONCRETE MIX SHALL BE M 15 CONFORMING TO IS 456-1978.
 3. REINFORCEMENT SHALL BE HIGH STRENGTH DEFORMED BARS OF GRADE F₄₁₅ CONFORMING TO IS 1786-1985.
 4. COVER TO REINFORCEMENT SHALL BE 18 mm IN SLABS

DETAIL OF A FLAT SLAB
(USING STRAIGHT BARS)
SHEET 17

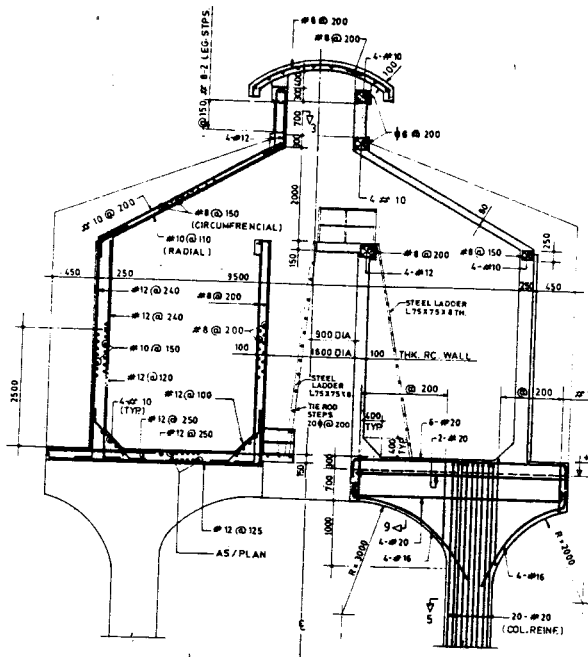

WALL AND SLAB REINFT
ELEVATION - OVER HEAD TANK

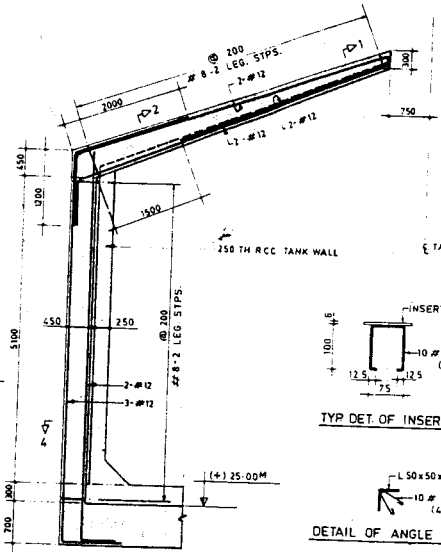

SECTION OF RIB SHOWING REINFT DETAILS

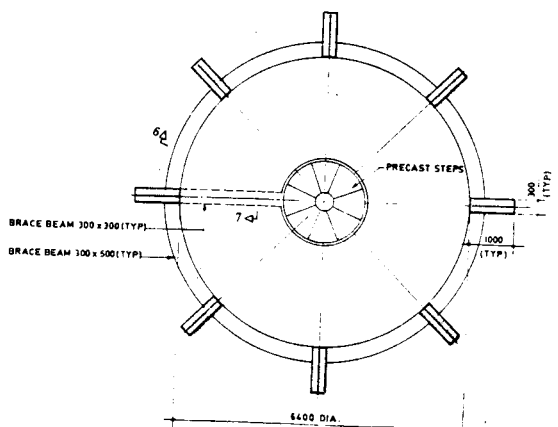

PLAN OF STAGING SHOWING COLUMNS & BRACINGS

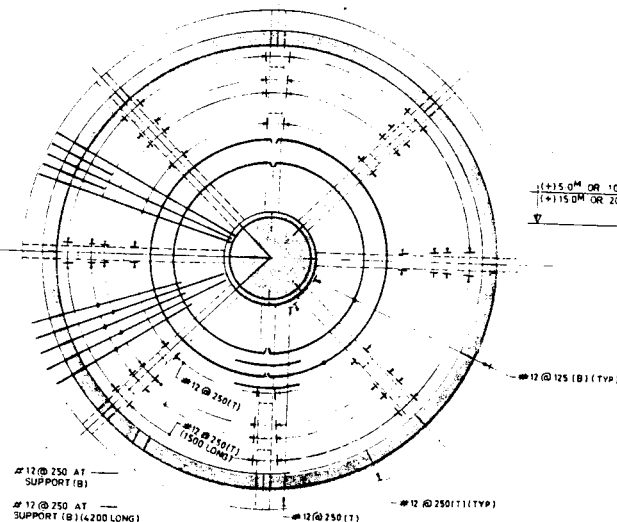

PLAN SHOWING REINFT IN THE BOTTOM SLAB OF TANK AT +25.00M LEVEL

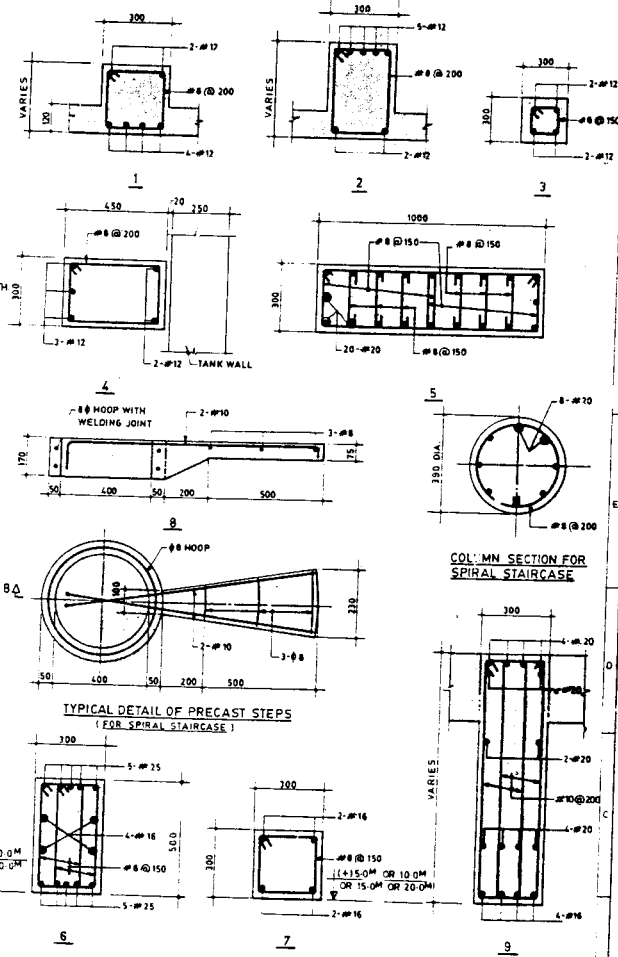

- GENERAL NOTES -**
1. ALL DIMENSIONS ARE IN MM AND LEVELS ARE IN METRES
 2. GRADE OF CONCRETE MIX SHALL BE M15 CONFORMING TO IS 456-1978
 3. REINFORCEMENT SHALL BE HIGH STRENGTH DEFORMED OF GRADE Fe 415 CONFORMING TO IS 1786-1985.

DETAILS OF OVER
HEAD TANK
SHEET 18

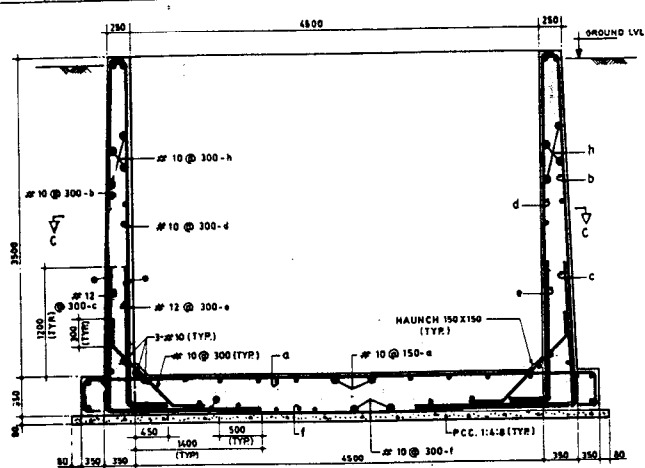

A-A

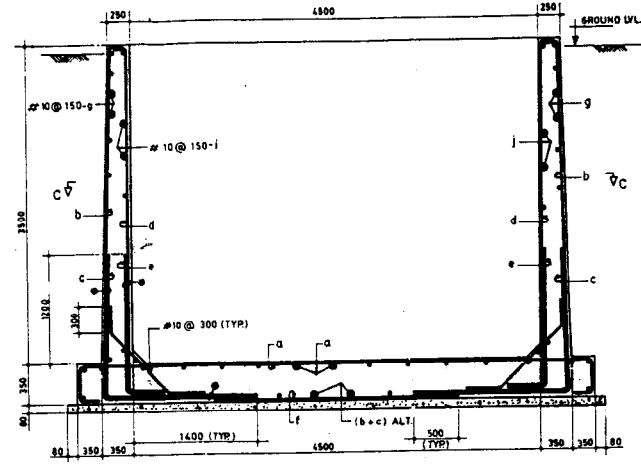

B-B

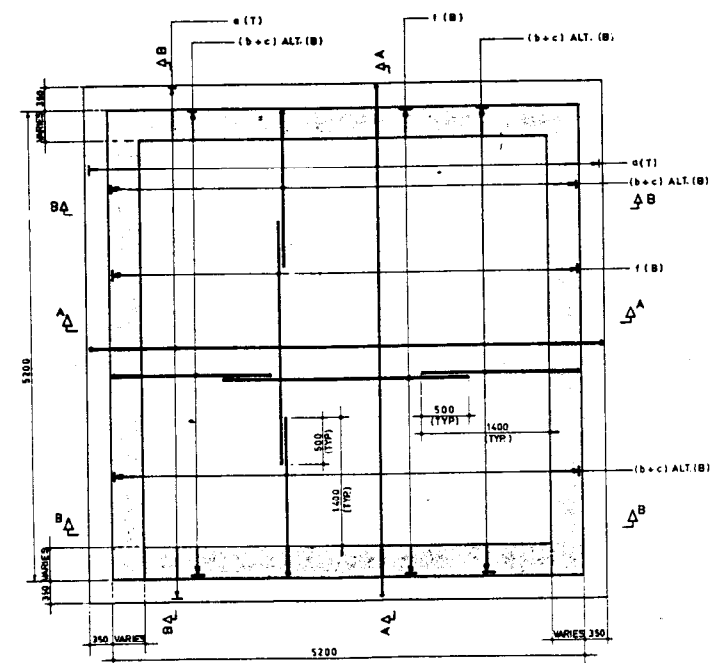

REINFORCEMENT DETAILS OF BASE SLAB

* BARS ARE IN THE SAME PLANE, BUT THEY ARE SHOWN TO BE IN DIFFERENT PLANES FOR THE PURPOSE OF CLARITY.

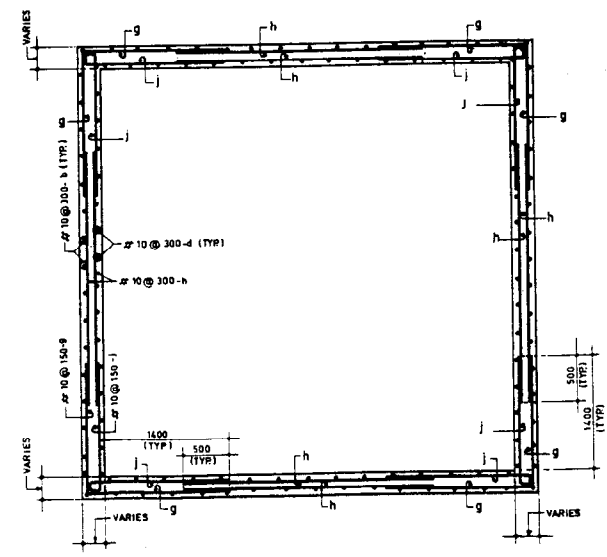

VIEW C-C

- GENERAL NOTES:
1. ALL DIMENSIONS ARE IN MM UNLESS NOTED OTHERWISE.
 2. GRADE OF CONCRETE MIX SHALL BE M 25 CONFORMING TO IS 456-1978.
 3. REINFORCEMENT BARS SHALL BE HIGH STRENGTH DEFORMED BARS OF GRADE Fe 415 CONFORMING TO IS: 1786-1985.

DETAILS OF UNDERGROUND WATER TANK-OPEN AT TOP
SHEET 19

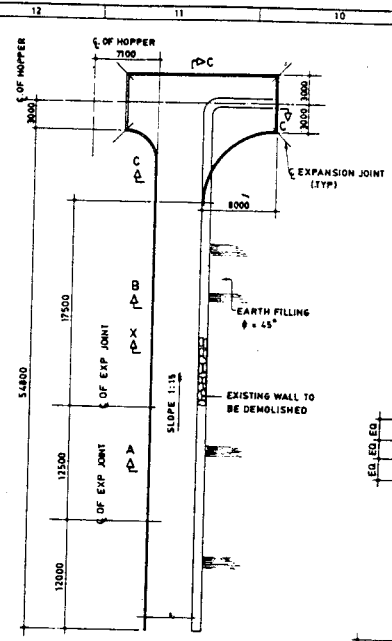

KEY PLAN

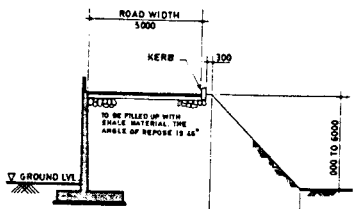

TYPICAL DETAIL OF EXPANSION JOINT

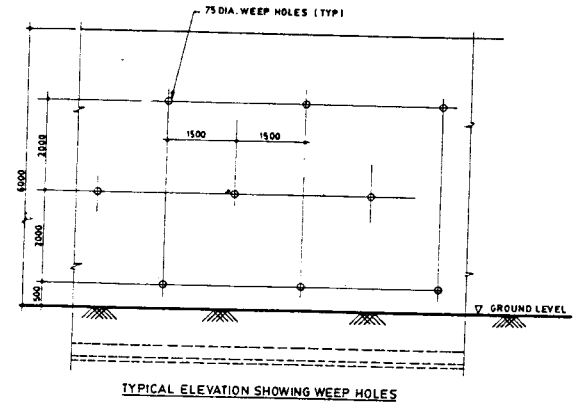

TYPICAL ELEVATION SHOWING WEEP HOLES

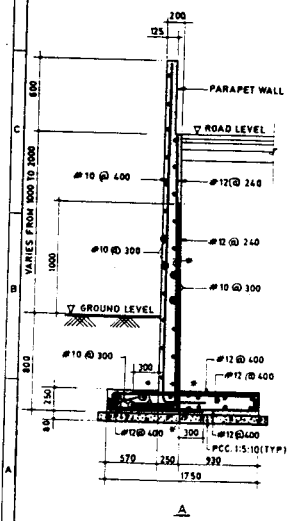
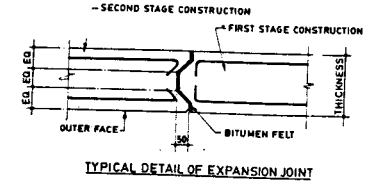

A

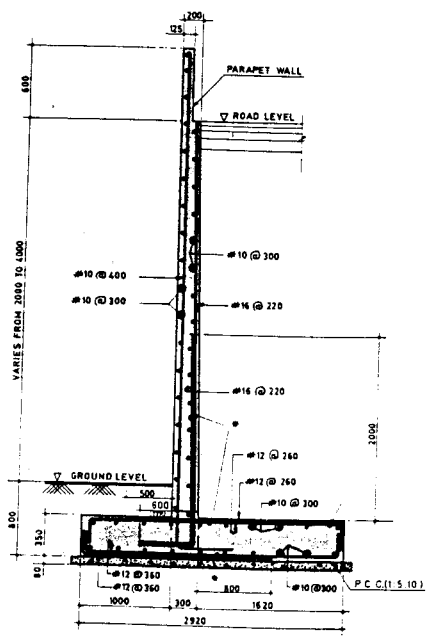

B

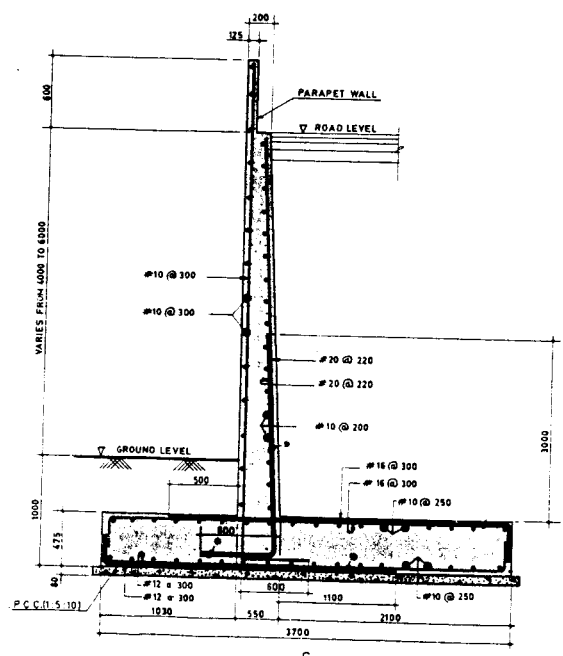

C

• BARS ARE IN THE SAME PLANE, BUT THEY ARE SHOWN TO BE IN DIFFERENT PLANES FOR THE PURPOSE OF CLARITY

- GENERAL NOTES:**
1. ALL DIMENSIONS ARE IN mm UNLESS NOTED OTHERWISE.
 2. GRADE OF CONCRETE MIX SHALL BE M 15 CONFORMING TO IS-458-1978.
 3. REINFORCEMENT SHALL BE HIGH STRENGTH DEFORMED BARS OF GRADE F₄₁₅ CONFORMING TO IS-1786-1975.
 4. COVER TO THE MAIN REINFORCEMENT IN BASE SLAB AND WALLS SHALL BE 50 mm.

DETAILS OF RETAINING WALL.
SHEET 20

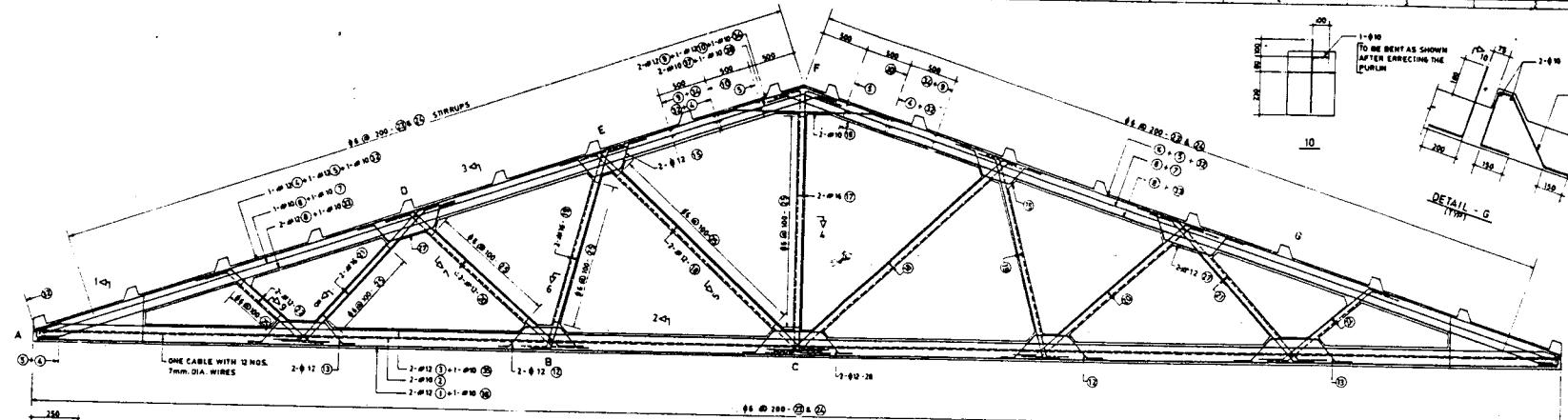

ELEVATION OF PRECAST TRUSS

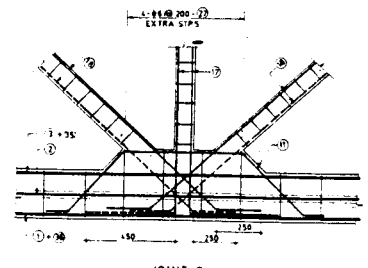
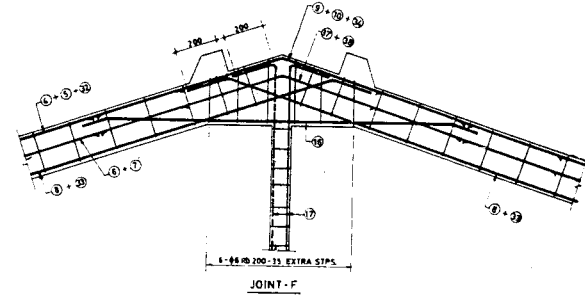
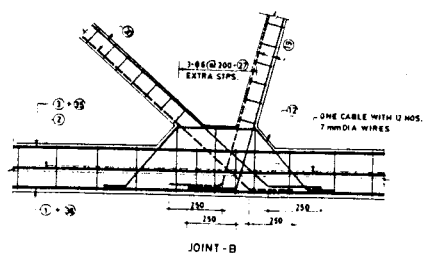
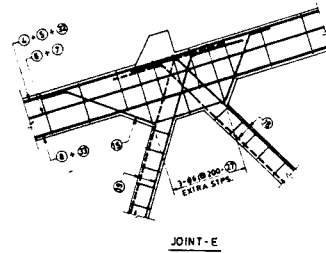
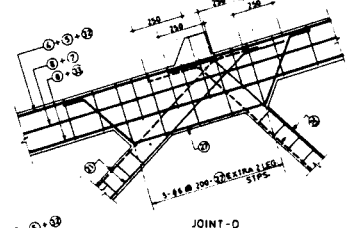
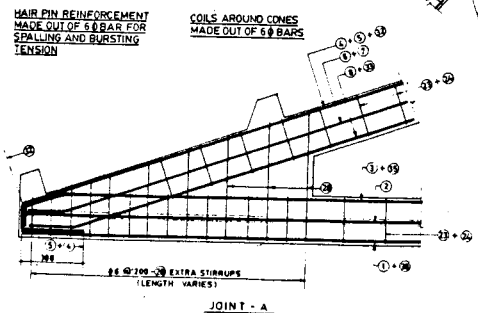
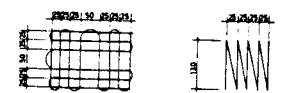
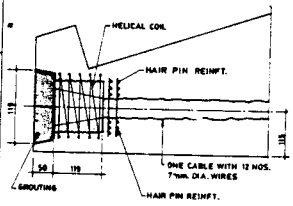
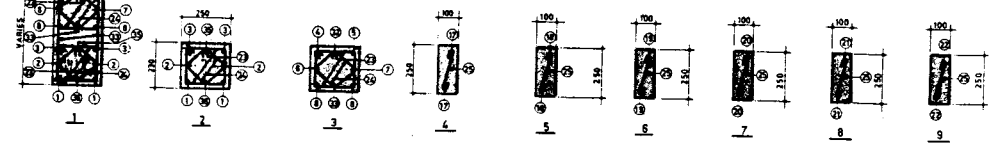

- GENERAL NOTES**
1. ALL DIMENSIONS ARE IN mm UNLESS NOTED OTHERWISE
 2. GRADE OF CONCRETE MIX SHALL BE M 35 CONFORMING TO IS 456-1977
 3. REINFORCEMENT MARKED Ø INDICATES DIAMETER OF MILD STEEL CONFORMING TO IS 432(PART I) 1985 AND MARKED σ INDICATES HIGH STRENGTH DEFORMED BARS CONFORMING TO IS 1786-1985.
 4. COVER TO REINFORCEMENT SHALL BE 30 mm.

DETAILS OF R.C.C. PRECAST TRUSS OF SPAN 18 M.
SHEET - 21

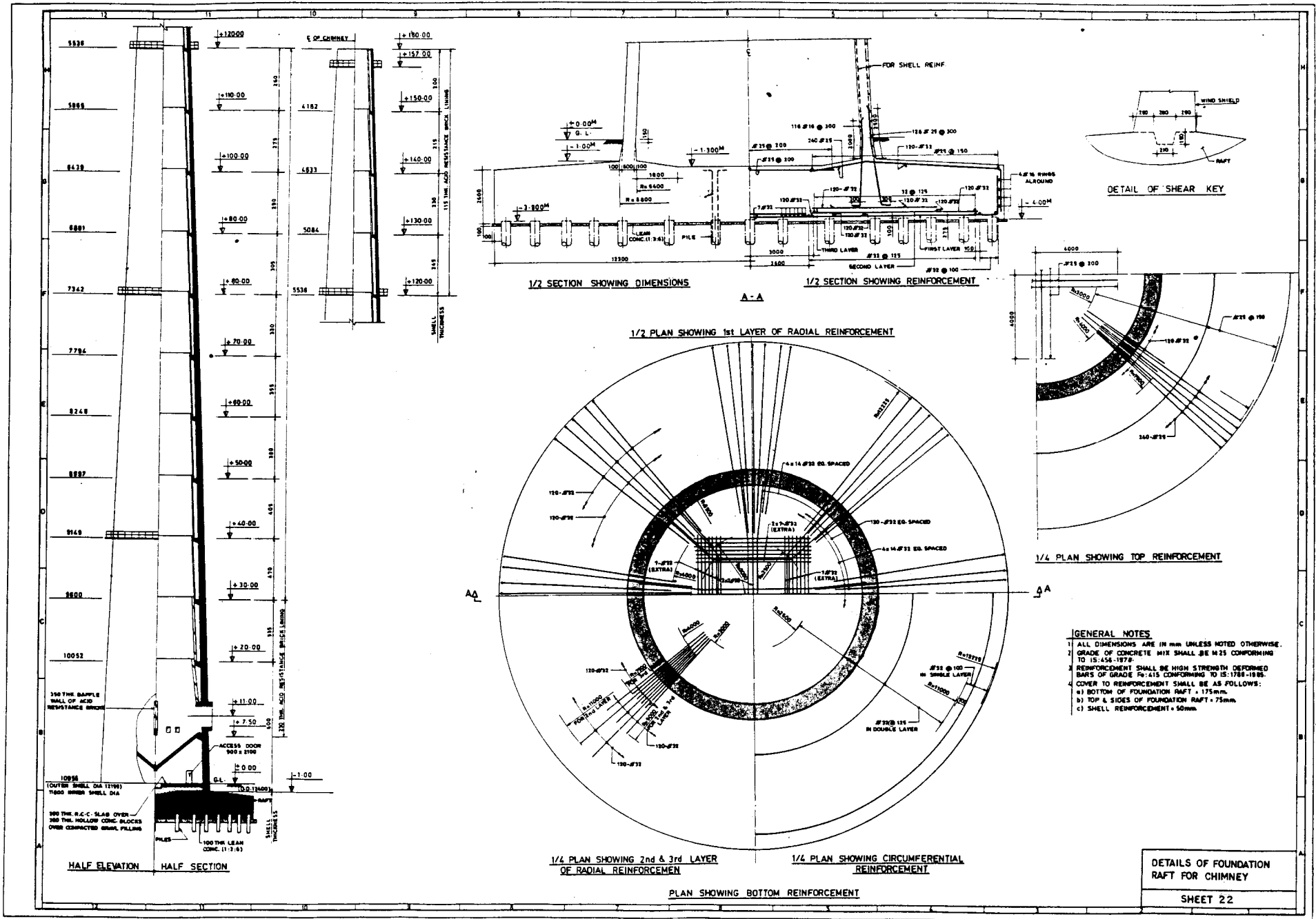

- GENERAL NOTES**
1. ALL DIMENSIONS ARE IN MM UNLESS NOTED OTHERWISE.
 2. GRADE OF CONCRETE MIX SHALL BE M25 CONFORMING TO IS:456-1978.
 3. REINFORCEMENT SHALL BE HIGH STRENGTH DEFORMED BARS OF GRADE F4-415 CONFORMING TO IS:1783-1985.
 4. COVER TO REINFORCEMENT SHALL BE AS FOLLOWS:
 - a) BOTTOM OF FOUNDATION RAFT = 175mm.
 - b) TOP & SIDES OF FOUNDATION RAFT = 75mm.
 - c) SHELL REINFORCEMENT = 50mm.

DETAILS OF FOUNDATION RAFT FOR CHIMNEY
SHEET 22

TO

SP : 34 (S & T) - 1987 HANDBOOK ON CONCRETE REINFORCEMENT AND DETAILING

(Page 30, clause 4.3.1.2) — Add the following matter at the end of the clause:

If for one bar size, straight anchorage length, L_{dt} will develop the tensile design yield stress in tension, then by bending a standard hook or bend at the end, a length $(L_{dt} - L_e)$ will develop the design yield stress also. This aspect is illustrated in the figure given below, where L_{dt} is the development length in tension and L_e is the anchorage value of hook/bend. In some cases the length $(L_{dt} - L_e)$ will have a negative value, in which case it shall be assumed that the hook/bend alone provides an adequate development length.

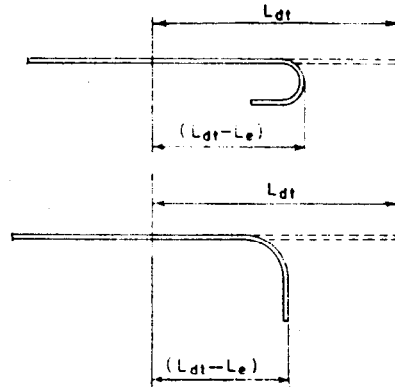

When hooks/bends do not conform to standard bends/hooks given in Table 4.1, anchorage value of hook/bend shall be neglected and the total development length provided (measured along bend/hook) shall be equal to the required development length (L_{dt}).

A few examples concerning development length in tension are illustrated in the following figures:

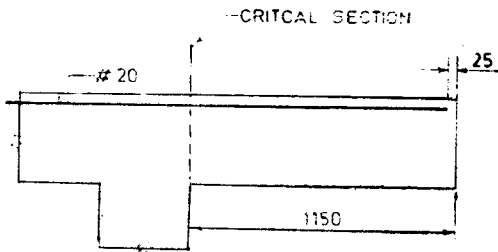

Available space for straight bar =
 $1150 - 25 = 1125$
 L_{dt} required (for # 20) = 1128
 \therefore Straight # 20 will fit

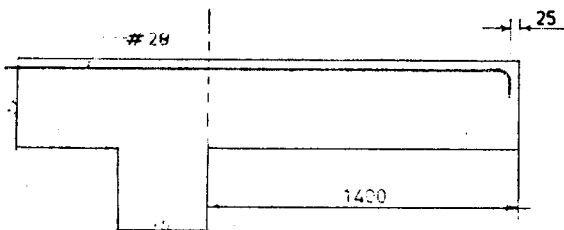

Available space for straight bar =
 $1400 - 25 = 1375$
 L_{dt} required (for # 28) = 1580
 Straight # 28 will not fit
 $(L_{dt} - L_e) = 1580 - 224 = 1356$
 \therefore # 28 Bar with standard bend will fit

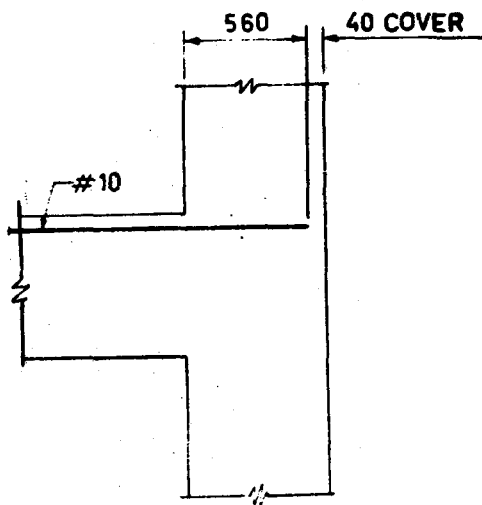

Available space for straight bar = 560
 L_{dt} required (for # 10) = 564
 \therefore Straight bar # 10 will fit

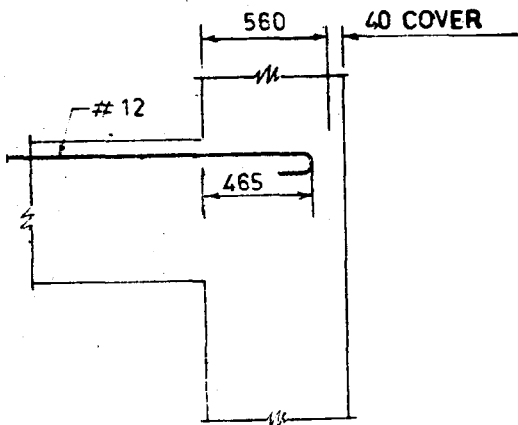

Available space for straight bar = 560
 L_{dt} required (for # 12) = 677
 Straight bar will not fit
 $(L_{dt} - L_e) = (677 - 192) = 485$
 \therefore # 12 with standard hook will easily fit

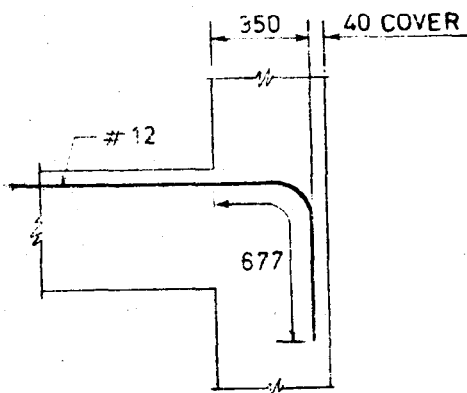

Available space for straight bar = 350
 L_{dt} required (for # 12) = 677
 $(L_{dt} - L_e) = (677 - 192) = 485$
 Straight bar with or without standard hook/bend will not be suitable
 \therefore Provide # 12 bar with full embedded length = 677 and also check for bearing stress at the end

(Page 41, clause 4.5.2) — Add the following at the end of the clause:

‘However this should be subject to the following conditions:

- a) Where the bar does not extend beyond a point four bar-diameters past the end of the bend; and
- b) Where the bar is assumed not to be stressed beyond a point four bar-diameters past the end of the bend at the ultimate design stress, that is, where the length of the bar extends beyond 4ϕ from end of the bend, it is not considered for development length.’

(Page 46, Fig. 4.18) — Delete ‘STANDARD’ in the legends.

(Page 47, Fig. 4.19) — Delete ‘STANDARD’ in the legends.

(Page 70, Fig. 6.1, Note 1) — Delete ‘standard’.

(Page 71, Fig. 6.2, Note) — Delete ‘standard’.

(Page 79, Fig. 6.11, SECTION AA) — Delete ‘STANDARD’ in the legend.

(Page 81, Fig. 6.13) — Substitute 'LAP SPLICES AT MID SPAN, IF REQUIRED' for 'LAP SPLICES AT MID SPAW, IF REQUIRED' and the same should be referred to top steel instead of bottom steel as shown by the arrow line.

(Page 129, Fig. 9.7A) — Delete 'STANDARD' in the legend.

(Pages 181 to 185, Fig. 11.29 to 11.33) — Change Fig. 11.29 to Fig. 11.32; Fig. 11.30 to Fig. 11.29; Fig. 11.31 to Fig. 11.30; and Fig. 11.32 to Fig. 11.31.

(Page 181, clause 11.9, line 5) — Substitute ' Fig. 11.34 ' for ' Fig. 11.32 '

(Page 185) — Add the following Fig. 11.34 below Fig. 11.33:

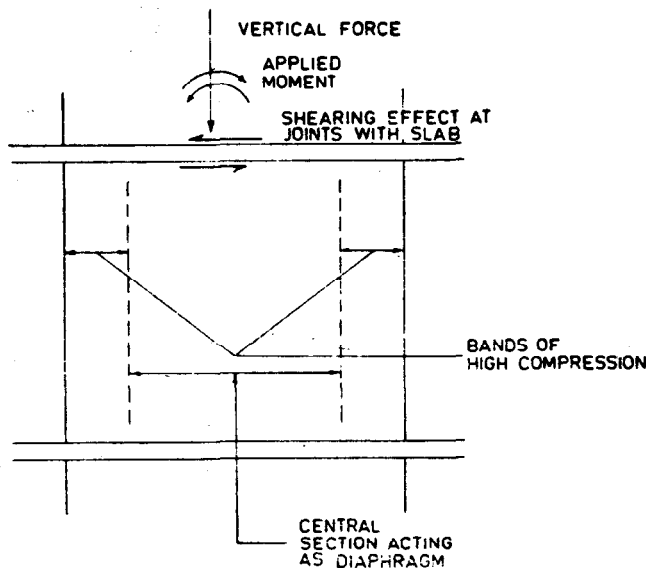

11.34A Forces in Shear Wall

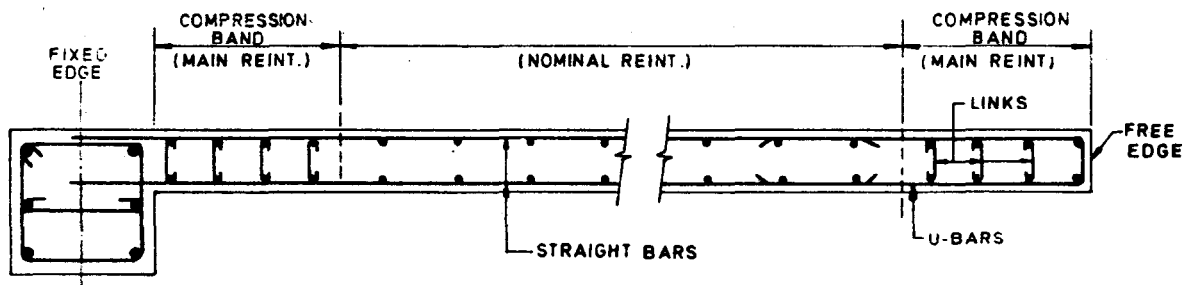

11.34B Cross Section Showing Typical Details
FIG. 11.34 SHEAR WALL

(Page 227, Table C-1, Sl No. 3) — Substitute '5'0' for '3'0' in col 3.

(Page 449, Sheet 8) — Substitute '(SEE SHEET 10 FOR REINFORCEMENT SCHEDULE)' for '(See SHEET 9 FOR REINFORCEMENT SCHEDULE)' in the title block.

(Page 253, Sheet 10) — Substitute '(REFER SHEET 8 FOR ARRANGEMENT OF REINFORCEMENT)' for '(REFER SHEET 9 FOR ARRANGEMENT OF REINFORCEMENT)'.

(SCIP)